

GE Fanuc Automation
Computer Numerical Control Products

***AC Spindle Motor
Series S/P/VH***

Descriptions Manual

GFZ-65012E/03



Warnings, Cautions, and Notes as Used in this Publication

Warning

Warning notices are used in this publication to emphasize that hazardous voltages, currents, temperatures, or other conditions that could cause personal injury exist in this equipment or may be associated with its use.

In situations where inattention could cause either personal injury or damage to equipment, a Warning notice is used.

Caution

Caution notices are used where equipment might be damaged if care is not taken.

Note

Notes merely call attention to information that is especially significant to understanding and operating the equipment.

This document is based on information available at the time of its publication. While efforts have been made to be accurate, the information contained herein does not purport to cover all details or variations in hardware or software, nor to provide for every possible contingency in connection with installation, operation, or maintenance. Features may be described herein which are not present in all hardware and software systems. GE Fanuc Automation assumes no obligation of notice to holders of this document with respect to changes subsequently made.

GE Fanuc Automation makes no representation or warranty, expressed, implied, or statutory with respect to, and assumes no responsibility for the accuracy, completeness, sufficiency, or usefulness of the information contained herein. No warranties of merchantability or fitness for purpose shall apply.

GE Fanuc: Your Source for the Best CNC

To locate your Sales Engineer or obtain Literature and Brochures, please call:
USA: **1-800-648-2001** (Email: telcon@fast.net) (www.gefanuc.com)
Canada: **1-800-268-3929**

CNC Commercial Services:

- **Order Placement**
- **Order Status**
- **Parts Price and Delivery**
- **Shipping Information**
- **Warranty**

Machine Tool Builders: 1-800-432-2621
Fax: 1-800-432-3291
Distributors and Users: 1-800-GE FANUC
(1-800-433-2682)
Fax: 1-804-978-5673

Technical Support Center (800) GE FANUC

GE Fanuc has established a Technical Support Center to assist you with technical problems and questions. The Technical Support Center is available twenty-four hours a day, 365 days a year.

Email: cnchotline@cho.ge.com
Fax: (804) 978-5516

Part Programming Systems (630) 932-6016

GE Fanuc offers a range of devices for CNC part program management. A full range of part programming software is also available.

Field Service (800) GE FANUC

If you have a more complex problem, GE Fanuc will dispatch one of its service engineers to your location. We have field service offices in California, Connecticut, Illinois, Indiana, Michigan, New York, North Carolina, Ohio, Texas, Virginia, Ontario and Quebec (Canada), and Neuvo Leon (Mexico).

Email: cnchotline@cho.ge.com
Fax: (804) 978-5516

Training (800) GE FANUC

GE Fanuc has designed a special training facility for customers in Charlottesville, Virginia, and maintains facilities in Chicago and Detroit. All CNC Training programs feature experienced instructors, quality documentation, and practical hands-on lab exercises.

Email: training@cho.ge.com
Fax: (804) 293-3900

Service Contracts (800) GE FANUC

GE Fanuc offers a variety of service contracts, which may be tailored to a customer's specific needs. Spot service is available on an hourly basis. Another service for our customers is the GE Fanuc Start-Up Assistance Program.

Technical Documentation (800) GE FANUC

Information on GE Fanuc controls is available in a wide range of instruction books. These include description manuals, operator's manuals, connection manuals, programming manuals, and maintenance manuals. Contact the numbers listed above.

Parts and Parts Repair Service (800) GE FANUC

GE Fanuc maintains an extensive parts inventory at our Charlottesville headquarters for all our CNCs. This inventory is outlined in our free Renewal Parts Catalog, which is available upon request. We also provide a repair and return service for our customers. Contact numbers listed above.

Email: gefanucparts@cho.ge.com
Fax: (804) 978-5673

Warranty Support (800) GE FANUC

GE Fanuc products have exceptional reliability. But, if a failure occurs within the warranty period, GE Fanuc will assist you in replacing the failed item. If you wish, a field engineer can be dispatched to troubleshoot the problem.

CNC Express (800) 432-2621

GE Fanuc Express provides easy ordering and quick delivery of the world's best CNC products in standard configurations. You can order your CNC or Motion Control system direct from our factory, with delivery from stock in as little as four weeks, using our CNC Express Catalog. Please contact your sales engineer or customer advocate for information regarding CNC Express.

Options and Enhancements (800) GE FANUC

With GE Fanuc Options, you can upgrade your CNC technology without scrapping your existing machine tools. If you need more tool offsets, probe and gauging capability, larger part program storage, improved programming functions, GE Fanuc can do the job.

Email: cncoptions@cho.ge.com



GE Fanuc Automation North America, Inc.
P.O. Box 8106 - CNC Business
Charlottesville, VA 22906

• All specifications are subject to change without notice.

• No part of this document may be reproduced in any form.

GFA-129B

TABLE OF CONTENTS

I. AC SPINDLE MOTOR S series

1. GENERAL	3
2. FEATURES	3
3. SPECIFICATION	4
3.1 Specifications	4
3.2 Output/Torque Characteristics	6
4. CONFIGURATION AND ORDER SPECIFICATION DRAWING NUMBER	14
4.1 Configuration	14
4.2 Order Specification Drawing Number	15
5. CONNECTIONS	21
6. CAUTIONS IN USE	22
7. EXTERNAL DIMENSIONS	26
7.1 AC Spindle Motor Model 1S	26
7.2 AC Spindle Motor Model 1.5S	27
7.3 AC Spindle Motor Model 2S	28
7.4 AC Spindle Motor Model 3S	29
7.5 AC Spindle Motor Model 6S	30
7.6 AC Spindle Motor Model 8S	31
7.7 AC Spindle Motor Model 12S, 15S	32
7.8 AC Spindle Motor Model 18S, 22S	33
7.9 AC Spindle Motor Model 1S/15000 (Flange type)	34
7.10 AC Spindle Motor Model 2S/15000 (Flange type)	34
7.11 AC Spindle Motor Model 3S/12000 (Flange type)	35
7.12 AC Spindle Motor Model 6S/12000 (Flange type)	35
7.13 AC Spindle Motor Model 8S/8000 (Flange type)	36
7.14 AC Spindle Motor Model 12S/8000, 15S/8000 (Flange type)	36
7.15 AC Spindle Motor Model 18S/6000, 22S/6000 (Flange type)	37

II. AC SPINDLE SERVO UNIT S series

1. GENERAL	41
2. FEATURES	41
3. CONFIGURATION AND ORDER SPECIFICATION DRAWING NUMBER	42
3.1 Models 1S - 3S	42
3.2 Models 6S - 22S	43
3.3 Order Specification Drawing Number	44
3.3.1 Models 1S - 3S, Model 1S/15000, Model 2S/15000 (high-speed model)	44
3.3.2 Models 6S - 22S, Models 3S/12000 - 22S/6000 (high-speed model)	45
4. SPECIFICATIONS AND FUNCTIONS	47
4.1 Specifications	47
4.2 Major Component Functions and Application	49
4.2.1 Spindle control unit	49
4.2.2 Resistance unit (Models 1S - 3S)	52

4.2.3	Resistor unit selection standard	53
4.2.4	Types of connectors	56
4.2.5	Fuse	58
4.2.6	Spindle orientation control circuit (option)	58
4.2.7	Speed gain switching circuit (option for Models 6S - 22S)	58
4.2.8	Power transformer (option)	58
4.2.9	Unit adaptor (option only for models 6S - 22S)	61
5.	INSTALLATION	62
5.1	Environmental Conditions	62
5.1.1	Ambient temperature	62
5.1.2	Humidity	62
5.1.3	Vibration	62
5.1.4	Atmosphere	62
5.2	Input Power and Grounding	62
6.	UNIT CALORIFIC VALUE	64
6.1	Calorific Value of the AC Spindle Servo Unit	64
7.	COOLING	65
7.1	AC Spindle Servo Unit	65
7.2	Cooling the Resistor Unit (Models 1S - 3S, Model 1S/15000, Model 2S/15000)	67
8.	EXTERNAL DIMENSIONS AND MAINTENANCE AREA	68
8.1	External Dimensions	68
8.1.1	AC spindle servo unit models 1S - 3S, model 1S/15000, model 2S/15000 (orientation using position coder)	68
8.1.2	AC spindle servo unit models 1S - 3S, model 1S/15000, model 2S/15000 (orientation using magnetic sensor)	69
8.1.3	Resistor unit (order specification: A06B-6052-K050)	70
8.1.4	Connector	70
8.1.5	AC line filter (order specification: A81L-0001-0083/3C)	71
8.1.6	AC spindle servo unit model 6S, 8S, 12S, model 3S/12000, 6S/12000, 8S/8000, 12S/8000, model 8P, 12P, 15P, 18P, model 8VH (with unit adaptor)	72
8.1.7	AC spindle servo unit model 6S, 8S, 12S, model 3S/12000, 6S/12000, 8S/8000, 12S/8000, model 8P, 12P, 15P, 18P, model 8VH (without unit adaptor)	73
8.1.8	AC spindle servo unit model 15S, 18S, 22S, model 15S/8000, 18S/6000, 22S/6000, model 22P, 30P, 40P, model 12VH (with unit adaptor)	74
8.1.9	AC spindle servo unit model 15S, 18S, 22S, model 15S/8000, 18S/6000, 22S/6000, model 22P, 30P, model 12VH (without unit adaptor)	76
8.1.10	Unit adaptor (models 6S - 12S, order specification: A06B-6059-K031)	78
8.1.11	Unit adaptor (models 15S - 22S, order specification: A06B-6059-K032)	80
8.1.12	Power transformer, models 1S - 3S (order specification: A06B-6052-J001)	82
8.1.13	Power transformer, models 6S, 8S (order specification: A06B-6044-J006)	83
8.1.14	Power transformer, models 12S, 15S (order specification: A06B-6044-J007)	84
8.1.15	Power transformer for Models 18S, 22S (order specification: A06B-6044-J010)	85

8.2	Maintenance Area	86
8.2.1	AC spindle servo unit models 1S, 1.5S, 2S, 3S, 1S/15000, 2S/15000 (orientation using position coder)	86
8.2.2	AC spindle servo unit models 1S, 1.5S, 2S, 3S, 1S/15000, 2S/15000 (orientation using magnetic sensor)	87
8.2.3	AC spindle servo unit model 6S, 8S, 12S, model 3S/12000, 6S/12000, 8S/8000, 12S/8000, model 8P, 12P, 15P, 18P, model 8VH (with unit adaptor)	88
8.2.4	AC spindle servo unit model 6S, 8S, 12S, model 3S/12000, 6S/12000, 8S/8000, 12S/8000, model 8P, 12P, 15P, 18P, model 8VH (without unit adaptor)	89
8.2.5	AC spindle servo unit model 15S, 18S, 22S, model 15S/8000, 18S/6000, 22S/6000, model 22P, 30P, model 12VH (with unit adaptor)	90
8.2.6	AC spindle servo unit model 15S, 18S, 22S, model 15S/8000, 18S/6000, 22S/6000, model 22P, 30P, 40P, model 12VH (without unit adaptor)	91
8.3	Panel Hole Machining Diagram and Mounting	92
8.3.1	AC spindle servo unit model 1S, 1.5S, 2S, 3S, model 1S/15000, 2S/15000	92
8.3.2	AC spindle servo unit model 6S, 8S, 12S, model 3S/12000, 6S/12000, 8S/8000, 12S/8000, model 8P, 12P, 15P, 18P, model 8VH	93
8.3.3	AC spindle servo unit model 15S, 18S, 22S, model 15S/8000, 18S/6000, 22S/6000, model 22P, 30P, 40P, model 12VH	94
9.	CONNECTION	95
9.1	Connection Diagram	95
9.1.1	Models 1S - 3S, 1S/15000, 2S/15000	95
9.1.2	Models 6S - 22S, 3S/12000 - 22S/6000, 8P - 40P, 8VH, 12VH	96
9.2	Cable Routing	97
9.2.1	Cable routing diagram of models 1S - 3S, 1S/15000, 2S/15000 ...	97
9.2.2	Cable routing diagram of models 6S - 12S, 3S/12000, 6S/12000, 8S/8000, 12S/8000, 8P, 12P, 15P, 8VH	98
9.2.3	Cable routing diagram of models 15S - 22S, 15S/8000, 18S/6000, 22S/6000, 22P, 30P, 40P, 12VH	99
9.3	Detailed Connection Diagram	100
9.3.1	Connection of power source	100
9.3.2	Connection of AC spindle servo unit and magnetics cabinet	102
9.3.3	Connection of AC spindle servo unit and AC spindle motor	108
9.3.4	Connecting AC spindle servo unit with unit adaptor (Models 6S - 22S)	110
9.3.5	Connection of AC spindle servo unit and resistor unit	112
10.	DESCRIPTIONS OF INTERFACE SIGNAL	114
10.1	Interface Signal Standards	114
10.2	Spindle Control Signals	116
10.2.1	Emergency stop signal (ESP1, 2)	116
10.2.2	Machine ready signal (MRDY1, 2)	117
10.2.3	Forward rotation command signal (SFR)	119
10.2.4	Reverse rotation command signal (SRV)	119
10.2.5	Analog voltage signal (DA2, E)	120
10.2.6	+15V power (+15V, E)	121
10.2.7	Spindle rotation speed override (OVR1, OVR2)	121
10.2.8	Torque limit command signals (TLM1, TLML, TLMH, OT)	123
10.2.9	Alarm reset signals (ARST1, 2)	124
10.3	Orientation Signal (ORCM1, 2)	124
10.4	Spindle Control Output Signals	124
10.4.1	Speed arrival signals (SAR1, 2)	124

10.4.2	Zero-speed detecting signals (SST1, 2)	127
10.4.3	Speed detecting signals (SDT1, 2)	127
10.4.4	Load detection signal (LTD1, 2)	129
10.4.5	Spindle alarm signals (ALM1, 2)	129
10.5	Alarm Content Signals (AL8, AL4, AL2, AL1)	131
10.6	Speed Indication Voltage Signal (SM1, OM)	134
10.7	Load Indication Voltage (LM1, OM)	135
11.	RIGID TAPPING	138
III. AC SPINDLE MOTOR P series		
1.	GENERAL	141
2.	FEATURES	141
3.	SPECIFICATIONS	142
4.	OUTPUT CHARACTERISTICS	143
5.	ORDER SPECIFICATIONS	147
5.1	AC Spindle Motor	147
5.2	AC Spindle Servo Unit	150
6.	CONNECTIONS	152
7.	PRECAUTIONS RELATED TO USE	153
8.	EXTERNAL DIMENSIONS	154
8.1	AC Spindle Motor Model 8P	154
8.2	AC Spindle Motor Model 12P, 15P	155
8.3	AC Spindle Motor Model 18P, 22P	156
8.4	AC Spindle Motor Model 30P, 40P	157
8.5	AC Spindle Motor Model 50P (Foot Mounting Type)	158
8.6	AC Spindle Servo Unit	158
IV. FANUC AC SPINDLE MOTOR VH series		
1.	GENERAL	161
2.	FEATURES	161
3.	SPECIFICATIONS	162
3.1	Specification Table	162
3.1.1	AC spindle motor VH series	162
3.1.2	AC spindle servo unit VH series	163
3.1.3	Miscellaneous	163
3.2	Oil Air Lubrication Conditions	164
3.3	Motor Cooling Conditions	164
3.4	Reference Drawing for Piping Parts	164
3.5	Output Characteristics	165
4.	ORDER SPECIFICATION DRAWING NUMBER	166
4.1	AC Spindle Motor	166
4.2	AC Spindle Servo Unit	166

5. OUTER DIMENSIONS	167
5.1 AC Spindle Motor	167
5.1.1 Model 6VH (liquid cooling type)	167
5.1.2 Model 8VH (liquid cooling type)	167
5.1.3 Model 12VH (liquid cooling type)	168

V. SPINDLE ORIENTATION

1. GENERAL	171
2. FEATURES	171
3. CONFIGURATION AND ORDER SPECIFICATION	172
3.1 Position Coder Type (Stop Position Internal Setting)	172
3.2 Position Coder Type (Stop Position External Command)	172
3.3 Magnetic Sensor Type	173
3.4 Order Specification Drawing Number	174
3.4.1 For models 1S - 3S	174
3.4.2 For models 6S - 22S	176
3.4.3 Built-in sensor signal conversion circuit	177
4. SPECIFICATIONS	178
4.1 Type	178
4.2 Specifications	180
4.2.1 Position coder system	180
4.2.2 Magnetic sensor system	182
5. EXTERNAL DIMENSIONS	184
5.1 Orientation Control PCB	184
5.1.1 Models 1S - 3S (position coder)	184
5.1.2 Models 1S - 3S (magnetic sensor)	184
5.1.3 Models 6S - 22S	185
5.2 Position Coder	185
5.2.1 Position coder C, D, G (with 160 x 160 flange)	185
5.2.2 Position coder E, F, H (without flange)	186
5.2.3 Position coder J, K, L (with 68 x 68 flange)	186
5.3 Magnetic Sensor	187
5.3.1 Types of magnetic sensor	187
5.3.2 Magnetizing element	188
5.3.3 Magnetic sensor	191
5.3.4 Precautions on use	191
6. CONNECTION DIAGRAM	192
6.1 Interface (For position coder)	192
6.1.1 Connection when synchronous feed position coder is concurrently used for lathes and machining centers	193
6.1.2 Connection for machining center spindle orientation only (No connection to NC)	194
6.1.3 Stop position external command connection	195
6.2 Interface (For magnetic sensor)	196
6.2.1 Magnetic sensor connection	197
7. INTERFACE SIGNALS	198
7.1 Description of Signals (up to 2-stage speed change gear spindle) ..	198
7.1.1 Orientation command signal (ORCM1, 2)	198
7.1.2 Orientation completion signal (ORAR1, 2)	199
7.1.3 Spindle high-speed/low-speed signal (CTH)	200
7.2 Description of Signals (When 3-stage speed change gear spindle) ...	200

7.2.1	Spindle medium speed signal (CTM)	201
7.3	Sequences	201
7.3.1	Orientation command while stopping	201
7.3.2	Orientation command during high-speed rotation	202
7.4	Description of Signals (Stop Position External Command Type of Position Coder System)	203
7.4.1	Stop position command signals (H01 to H12-OL)	203
8.	DETECTOR SPECIFICATIONS	205
8.1	Position Coder	205
8.2	Magnetic Sensor	207
9.	TWO-MAGNETIC SENSOR ORIENTATION	215
9.1	General	215
9.2	Configuration	215
9.3	Change-over Circuit	216
9.3.1	Selection signal of magnetic sensor (SB signal)	216
9.3.2	Signal change-over relay	216
9.4	Fine Adjustment for Stop Position	217
VI.	SPEED GAIN SWITCHING CIRCUIT	
1.	GENERAL	221
2.	FEATURES	221
3.	CONFIGURATION AND ORDER SPECIFICATIONS	221
3.1	Configuration	221
3.2	Order Specifications	221
4.	EXTERNAL DIMENSIONS	222
5.	DESCRIPTIONS OF INTERFACE SIGNALS	222
5.1	Forward Rotation Command Signals (SFR, OS)	222
5.2	Orientation Command Signals (ORCM1, ORCM2)	222
6.	OPERATION WHEN USING THE SPEED GAIN SWITCHING CIRCUIT	223
6.1	Operation at the Time of Stop	223
6.2	Operation as from Rotating at High Speed	223
VII.	BUILT-IN SENSOR SIGNAL CONVERSION CIRCUIT	
1.	GENERAL	227
2.	FEATURES	227
3.	CONFIGURATION AND ORDER SPECIFICATIONS	227
3.1	Configuration	227
3.1.1	When position coder system orientation is used	227
3.1.2	When position coder system orientation is not used	227
3.2	Order Specifications	228
3.2.1	Built-in sensor signal conversion circuit	228
3.2.2	Built-in sensor built-in type AC spindle motor	228
4.	SPECIFICATIONS	229
4.1	Position Coder Output Signal	229
4.1.1	Number of detection gear teeth and output pulses	229

4.1.2	Output signal specifications (connector CN2 signal) at constant speed of 1500 rpm	229
4.1.3	Output circuit configuration	230
4.2	Input Power Source	230
4.3	Maximum Speed for Use	230
4.4	Temperature Range for Use	230
5.	ADJUSTMENT	231
5.1	Configuration of Output Signal (Speed Detection Signal)	231
5.2	Offset Adjustment (Position Detection Signal)	231
5.3	Example of Wave Pattern	231
6.	EXTERNAL DIMENSIONS AND EXAMPLE OF MOUNTING	232
6.1	Built-in Sensor Signal Conversion Circuit	232
6.2	Built-in Sensor Built-in Type AC Spindle Motor	232
6.3	Example of Mounting	232
7.	CONNECTION	233
7.1	When using Position Coder Method Orientation	233
7.2	When not using Position Coder Method Orientation	233
7.3	Details of Connection between Each Unit	234
7.3.1	Built-in sensor and connector (Motor) (Cable symbol: K10)	234
7.3.2	Motor and built-in sensor signal conversion circuit (Cable symbol: K11)	235
7.3.3	Built-in sensor signal conversion circuit and position coder method orientation circuit (Cable symbol: K02)	236
7.3.4	Built-in sensor signal conversion circuit and AC spindle servo unit (Cable symbol: K03)	237
7.3.5	Position coder method orientation circuit and NC (Cable symbol: K04)	238
7.3.6	Built-in sensor signal conversion circuit and NC (Cable symbol: K05)	239
8.	CABLE	240
8.1	List of Cables	240
8.2	Details of the Cable (K10)	241
9.	NOTE	243

VIII. OUTPUT CONVERSION CONTROL

1.	GENERAL	251
2.	COMPONENTS AND ORDER DRAWING NUMBER	251
2.1	Components	251
2.2	Order Drawing Number	251
3.	SPECIFICATIONS	252
4.	EXTERNAL DRAWING	253
4.1	AC Spindle Servo Unit S Series (when an output switching control circuit is mounted)	253
4.1.1	AC spindle servo unit models 6S - 12S (without unit adaptor)	253
4.1.2	AC spindle servo unit models 15S - 22S (without unit adaptor)	254
4.1.3	Outline drawing of the output conversion control circuit	255

5.	INSTALLATION	255
6.	CONNECTION	256
6.1	a) Connection Diagram (Type A)	256
6.1	b) Connection Diagram (Type B)	257
6.2	Connectors	258
7.	EXPLANATION OF INTERFACE SIGNAL	259
7.1	Input Signals	259
7.1.1	Conversion demand signal (SEL1, 2)	259
7.1.2	Power cable status confirmation signal (MCF1, 2)	259
7.2	Output Signals	260
7.2.1	Speed detection signal (SDT1, 2)	260
7.2.2	Power cable conversion signal (CHP1, 2)	260
7.2.3	Conversion completion signal (CFIN1, 2)	261
8.	SEQUENCE	262
8.1	Low-speed Output (LOW) - High-speed Output (HIGH)	262
8.2	High-speed Output (HIGH) - Low-speed Output (LOW)	263
9.	EXAMPLE CONNECTION FOR THE ELECTROMAGNETIC CONTACTOR SWITCHING CIRCUIT	264
10.	PRECAUTIONS RELATED TO USE	265

IX. SPINDLE SWITCHING CONTROL CIRCUIT

1.	OUTLINE	269
2.	CONFIGURATION AND ORDER SPECIFICATION	269
2.1	Configuration	269
2.2	Order Specification	270
3.	SPECIFICATIONS	271
4.	OUTER DIMENSIONS	272
4.1	Spindle Switching Control Circuit	272
5.	CONNECTIONS	273
5.1	Connections	273
5.2	Signal Distribution	274
6.	INTERFACE	275
6.1	Input Signal	275
6.1.1	Selector demand signals (SEL1, 2)	275
6.1.2	Power line status confirmation signals (MCF1, 2)	275
6.2	Output Signals	276
6.2.1	Power line selector signal (CHP1, 2)	276
6.2.2	Selector completion signal (CFIN1, 2)	276
7.	SEQUENCE	277
8.	IMPORTANT POINTS FOR USING SPINDLE SELECTION CONTROL	278

APPENDIX

APPENDIX 1	CABLE SPECIFICATIONS	281
APPENDIX 2	TECHNICAL DATA	286
APPENDIX 3	EXAMPLE OF COOLING FAN MOTOR OF UNIT (Used in July, 1990 or earlier)	323
APPENDIX 4	GROUNDING	324

I. AC SPINDLE MOTOR S series

1. GENERAL

The FANUC AC SPINDLE MOTOR S series have been specially developed as highly reliable and high-performance variable-speed AC spindle motors for the most advanced CNC machine tools. By using the new stator cooling system which directly cools the electromagnetic steel sheet, the compact FANUC AC spindle motor allows high power output and high-speed revolution.

2. FEATURES

Based on the long-time field experience as the spindle motors for CNC machine tools and accumulated technologies, the FANUC AC spindle motor S series have a variety of excellent features as shown below.

- 1) The motor is compact, light-weight and furnished with digital control for much higher performance.
- 2) The rotor inertia of the AC spindle motor is made smaller to shorten the acceleration/deceleration speed. Further, optimum control enables highly efficient cutting.
- 3) The motor incorporating the position coder required for synchronous feed of the spindle and Z axis and machining rigid tapping can be used.
- 4) Improvement in machining of the motor housing enhances the accuracy of the mounting part. And improvement of the cooling fan motor and that of the sealing structure of the housing enhance the reliability and environment-proof characteristics.

3. SPECIFICATION

3.1 Specifications

1) AC spindle motor S series

Table 3.1 (a) Specification Table

Items		Models										
		1S	1.5S	2S	3S	6S	8S	12S	15S	18S	22S	
Output power	Continuous rated output (*1)	kW (HP)	1.5 (2.0)	1.1 (1.5)	2.2 (3.0)	3.7 (5.0)	5.5 (7.4)	7.5 (10)	11 (14.7)	15 (20.1)	18.5 (24.8)	22 (29.5)
	30-minute rated (*1) (15-minute rated) (*3)	kW (HP)	2.2 (3.0)	3.7 (5.0)	3.7 (5.0)	5.5 (7.4)	7.5 (10)	11 (14.7)	15 (20.1)	18.5 (24.8)	22 (29.5)	26 (34.9)
	50% ED rated output (*1,*2)	kW (HP)	2.2 (3.0)	3.7 (5.0)	3.7 (5.0)	5.5 (7.4)	7.5 (10)	11 (14.7)	15 (20.1)	18.5 (24.8)	22 (29.5)	26 (34.9)
Rotating speed	Base speed	rpm	3,000	1,500	1,500	1,500	1,500	1,500	1,500	1,500	1,500	1,500
	Maximum speed	rpm	8,000	8,000	8,000	6,000	6,000	4,500 6,000	4,500 6,000	4,500 6,000	4,500	4,500
Output torque (Continuous rated torque at constant torque range)		N.m (kg.cm)	4.77 (49)	6.82 (69)	14.0 (143)	23.5 (240)	35.0 (357)	47.7 (487)	70 (714)	95.4 (974)	117.7 (1201)	140 (1428)
GD ²		kg.m ²	0.012	0.017	0.031	0.059	0.086	0.11	0.36	0.36	0.51	0.51
Rotor inertia		N.m.sec ² (kg.cm.sec ²)	0.003 (0.03)	0.004 (0.04)	0.0082 (0.08)	0.015 (0.15)	0.022 (0.22)	0.027 (0.28)	0.091 (0.93)	0.091 (0.93)	0.126 (1.29)	0.126 (1.29)
Weight		kg	18	24	27	46	60	80	110	110	143	143
Cooling system		Totally enclosed fan cooled										
Installation		The output shaft should be horizontal or vertically downward.										
Allowable overload capacity (1 min.)		120% of 30 minute-rating										
Insulation		Class F										
Ambient temperature		0 - 40°C										
Vibrations		V5										
Noise		75 dB (A)										
Painting color		Munsell system N2.5										
Accessories		Pulse generator and thermostat										

(*1) The rated output is guaranteed at the rated input voltage (200V/220V/230VAC). If the input voltage fluctuates, it is possible that the rated output cannot be obtained even when such fluctuations are within the allowable fluctuation range.

(*2) The cycle time is 10 minutes, 50% ED: ON 5 min, OFF 5 min. For model 1.5S: 30% ED, ON 3 min, OFF 7 min.

(*3) For models 1S and 2S data is in 15-minute rated output. For model 1.5S data is in 10-minute rated output.

2) AC spindle motor S series (high-speed model)

Table 3.1 (b) Specification Table

Items		Models	1S/ 15000	2S/ 15000	3S/ 12000	6S/ 12000	8S/ 8000	12S/ 8000	15S/ 8000	18S/ 6000	22S/ 6000
Output	Continuous rated output (*1)	kW (HP)	1.5 (2.0)	2.2 (3.0)	3.7 (5.0)	5.5 (7.4)	7.5 (10)	11 (14.7)	15 (20.1)	18.5 (24.8)	22 (29.5)
	30-minute rated (15-minute rated) (*1, *2, *5)	kW (HP)	2.2 (3.0)	3.7 (5.0)	5.5 (7.4)	7.5 (10)	11 (14.7)	15 (20.1)	18.5 (24.8)	22 (29.5)	26 (34.9)
	50% ED rated output (*1, *2, *5)	kW (HP)	2.2 (3.0)	3.7 (5.0)	5.5 (7.4)	7.5 (10)	11 (14.7)	15 (20.1)	18.5 (24.8)	22 (29.5)	26 (34.9)
Rotation speed	Base speed	rpm	3000	3000	1500	1500	1500	1500	1500	1500	1500
	Maximum speed	rpm	15000	15000	12000	12000	8000	8000	8000	6000	6000
Output torque (*6)		N.m (kg.cm)	4.77 (49)	7 (71.4)	23.5 (240)	35.0 (357)	47.7 (487)	70 (714)	95.4 (974)	117.7 (1201)	140 (1428)
GD ²		kg.m ²	0.012	0.031	0.059	0.086	0.11	0.36	0.36	0.51	0.51
Rotor inertia		N.m.sec ² (kg.cm.sec ²)	0.003 (0.03)	0.008 (0.08)	0.015 (0.15)	0.022 (0.22)	0.027 (0.28)	0.091 (0.93)	0.091 (0.93)	0.126 (1.29)	0.126 (1.29)
Weight		kg	18	27	46	60	80	110	110	143	143
Allowable radial load		kg	40	50	100	150	200	250		450	
Vibration		V5									
Noise		75 dB									
Cooling system		Totally enclosed outer fan type									
Cooling fan		56 W					68 W				
Installation		The output shaft should be horizontal or vertically downward.									
Allowable overload capacity (for 1 min.)		120% of 30-min. rating									
Insulation		Class F									
Ambient temperature		0 - 40°C									
Painting color		Munsell system N2.5									
Accessories		Pulse generator, thermostat									
No. of built-in sensor pulses (optional)		512 p/rev					1024 p/rev				
Bearing lubrication		Grease									

(*1) The rated output is guaranteed at the rated input voltage (200V/220V/230V AC). If the input voltage fluctuates, it is possible that the rated output cannot be obtained even when such fluctuations are within the allowable fluctuation range.

(*2) Models 1S and 2S are 15-min. rated.

(*3) With a cycle time of 10 minutes and 50% ED: the ON period will be 5 min. and the OFF period 5 min.

(*4) The servo unit is not equipped with the cooling fan for the radiator.

(*5) Guaranteed when separately stipulated thermal conditions for the servo unit are satisfied.

(*6) Output torque is expressed as "Continuous rated torque in the rated torque range."

3.2 Output/Torque Characteristics

1) S series

MODEL 1S

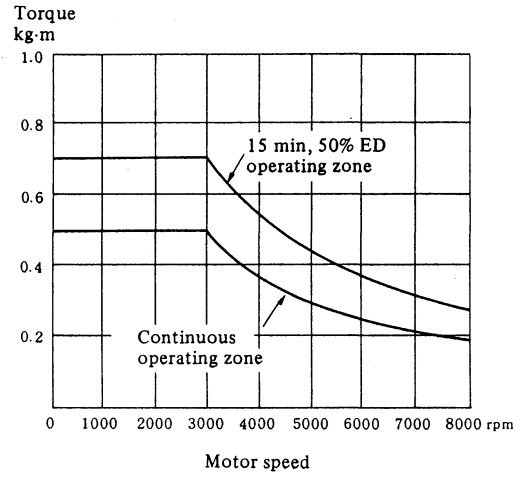
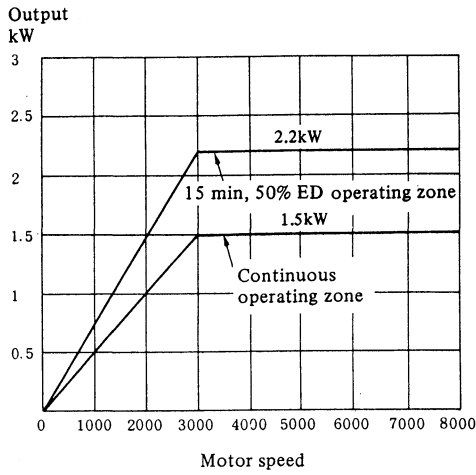

MODEL 1.5S

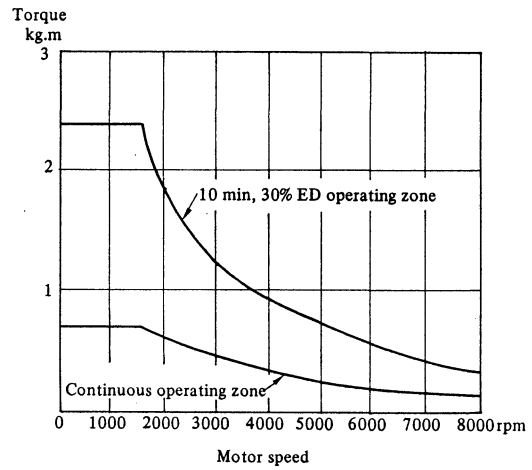
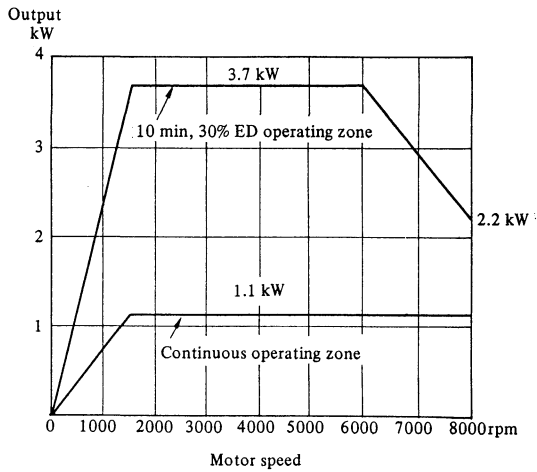

MODEL 2S

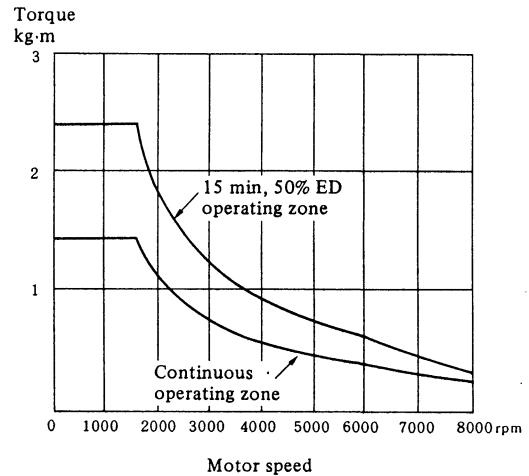
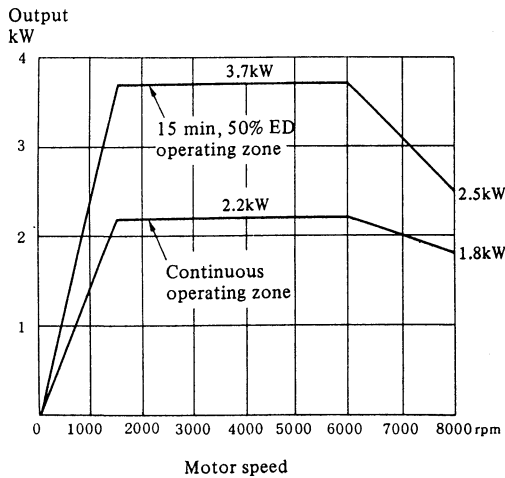

MODEL 3S

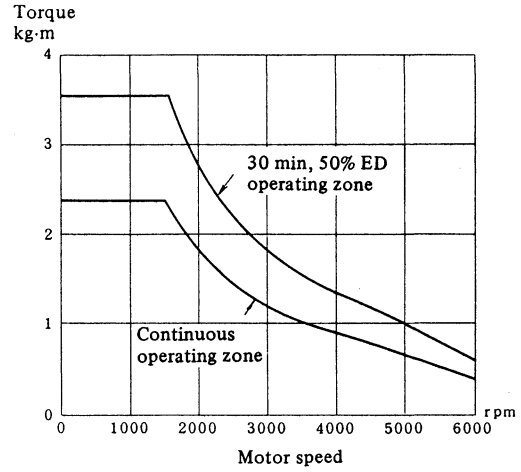
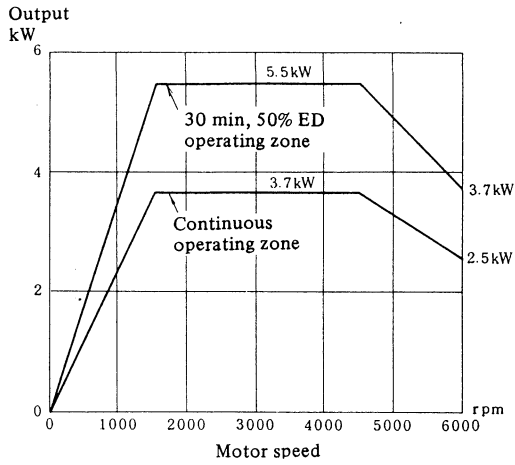

MODEL 6S

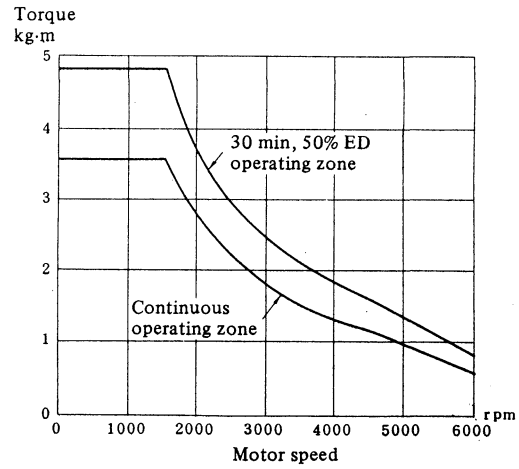
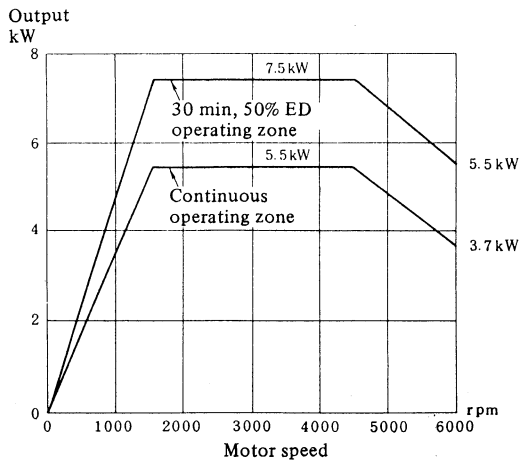

MODEL 8S

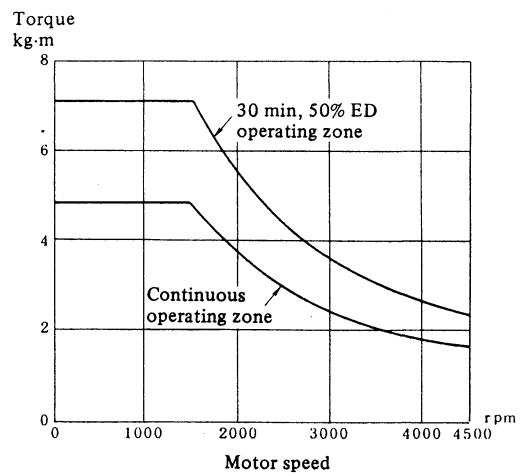
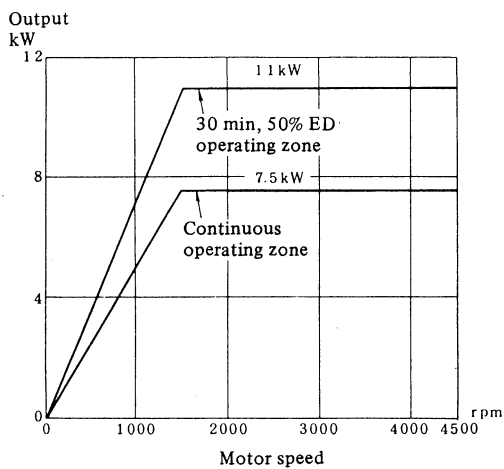

MODEL 8S

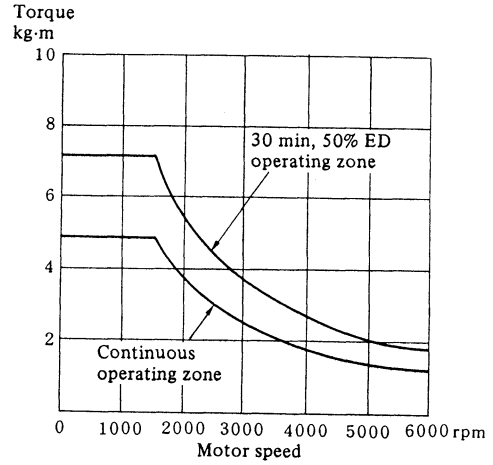
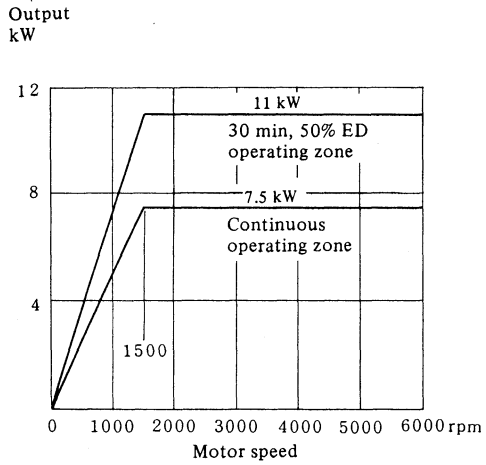

MODEL 12S

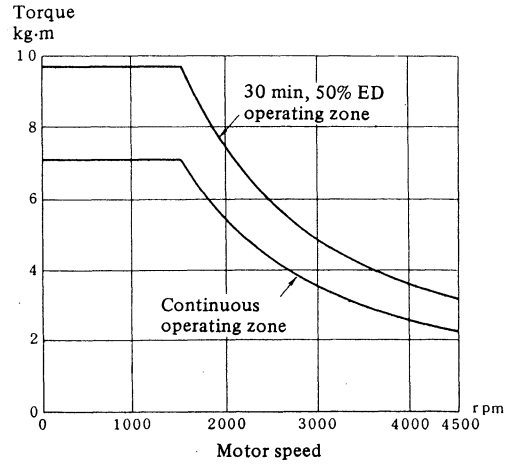
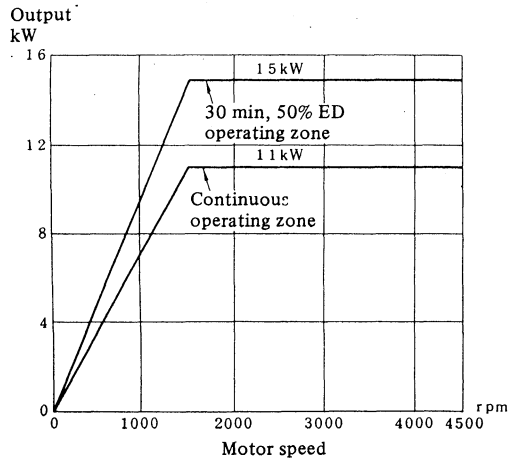

MODEL 12S

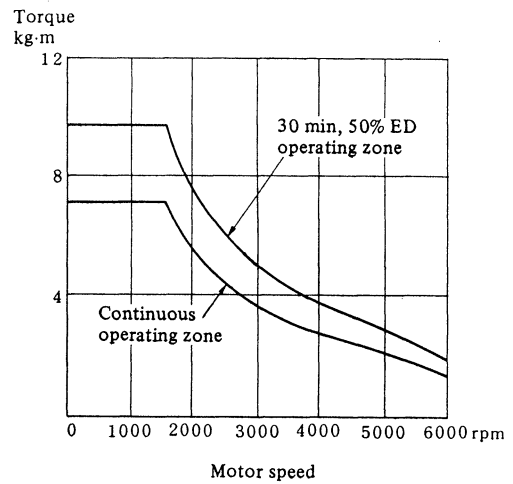
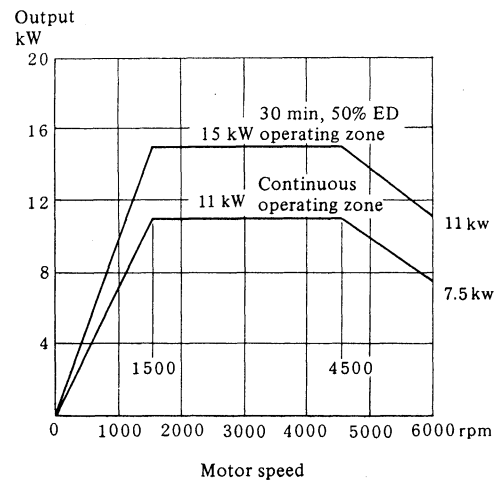

MODEL 15S

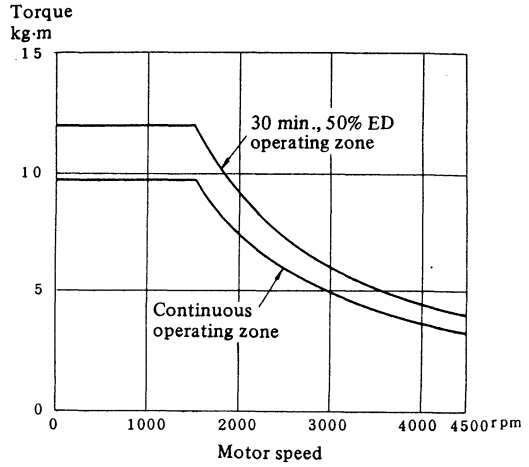
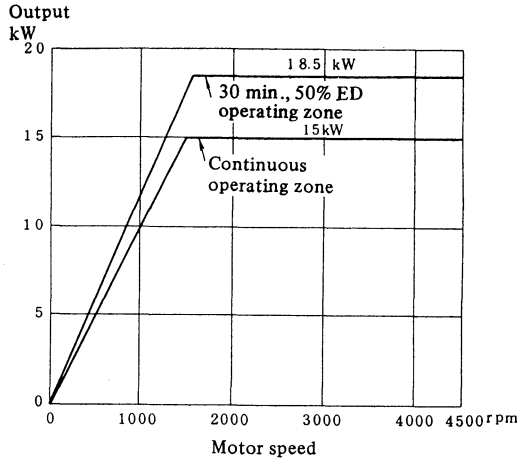

MODEL 15S

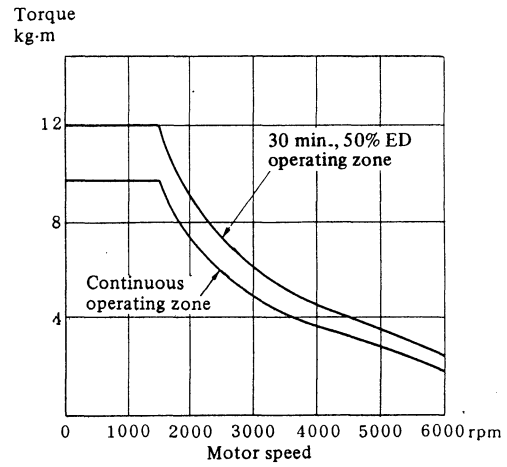
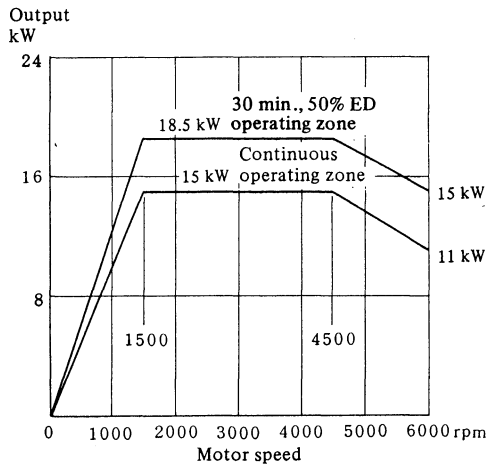

MODEL 18S

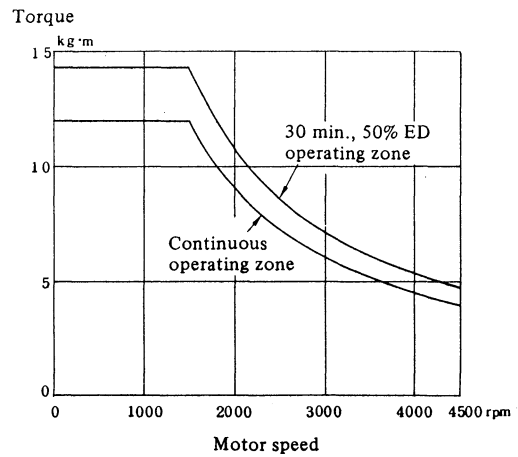
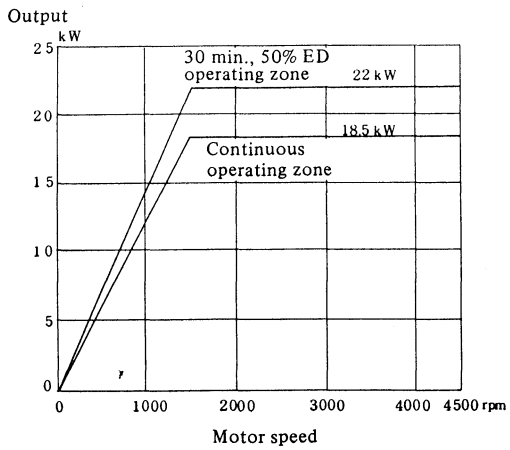

MODEL 22S

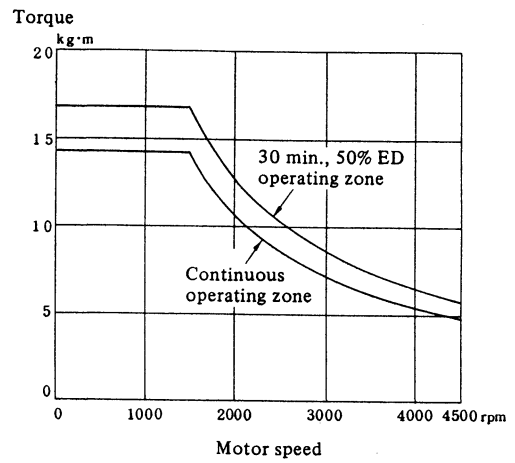
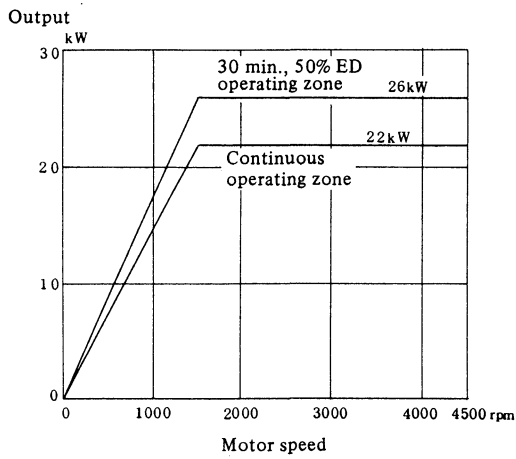

2) S series (high-speed model)

Model 1S/15000

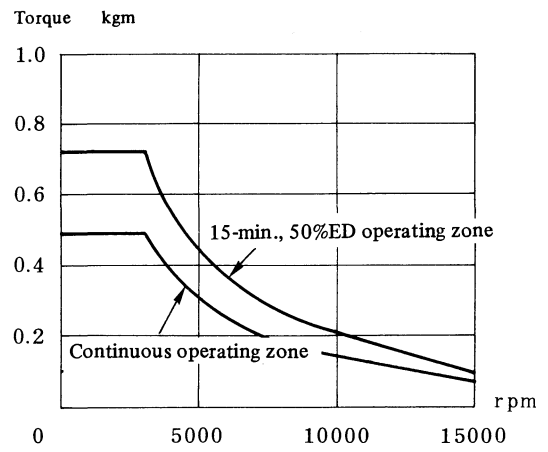
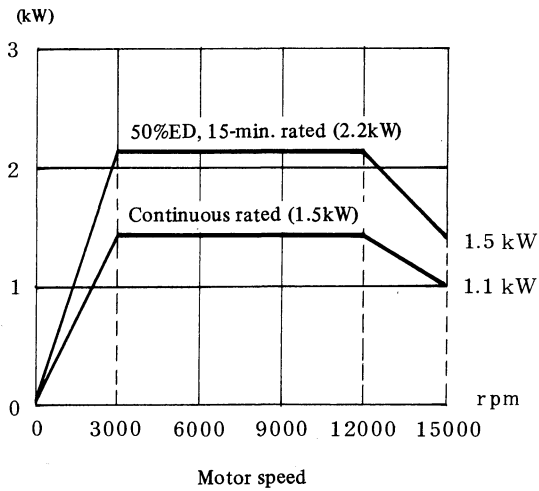

MODEL 2S/15000

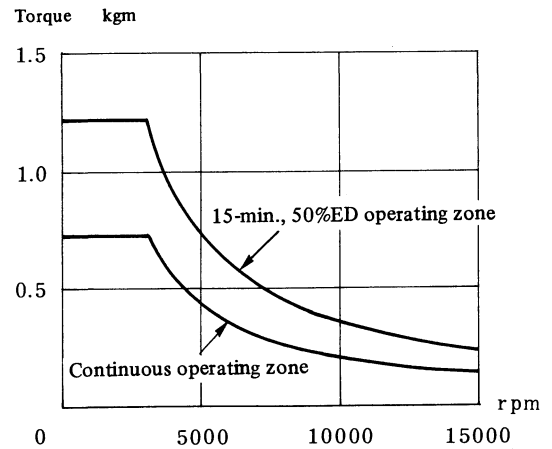
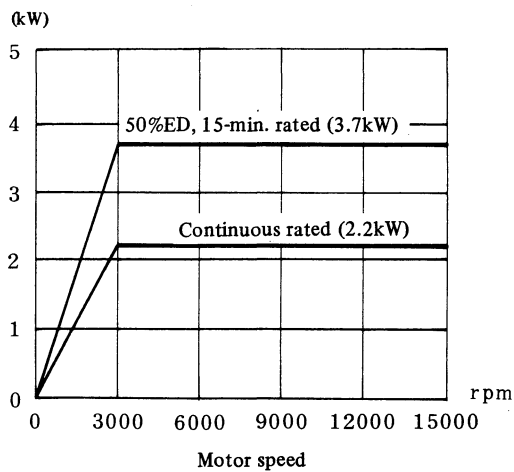

MODEL 3S/12000

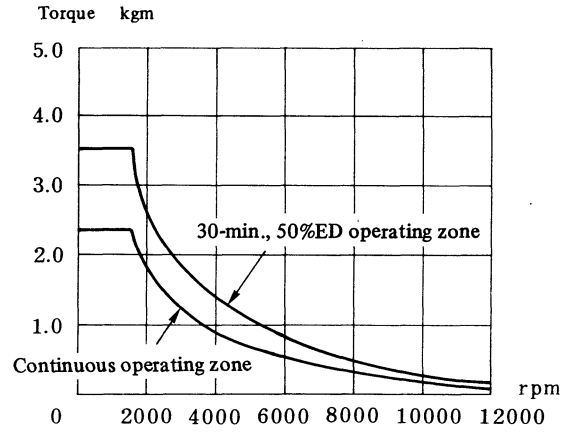
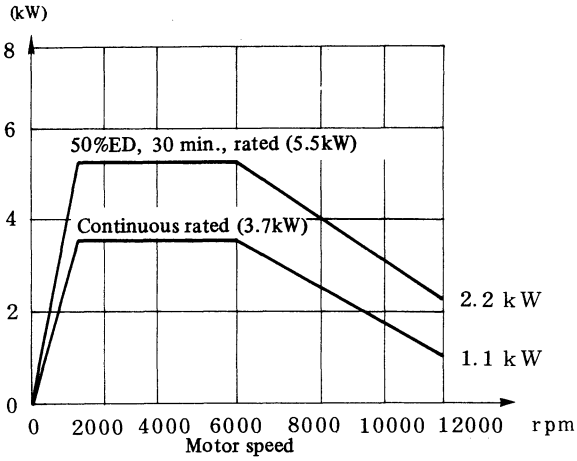

MODEL 6S/12000

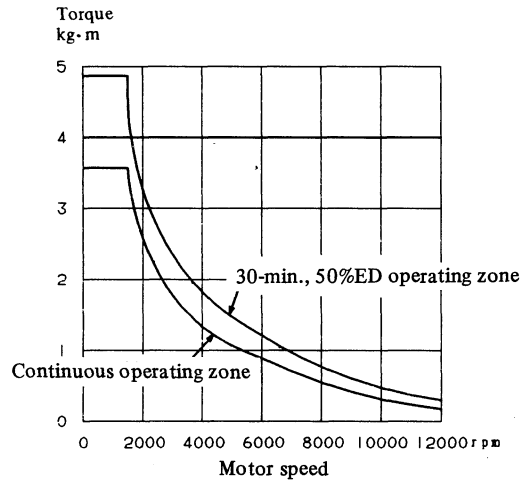
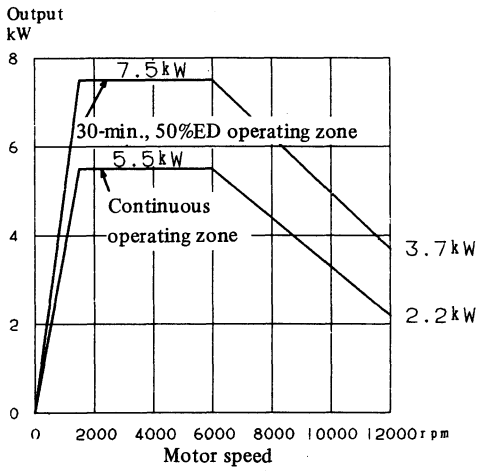

MODEL 8S/8000

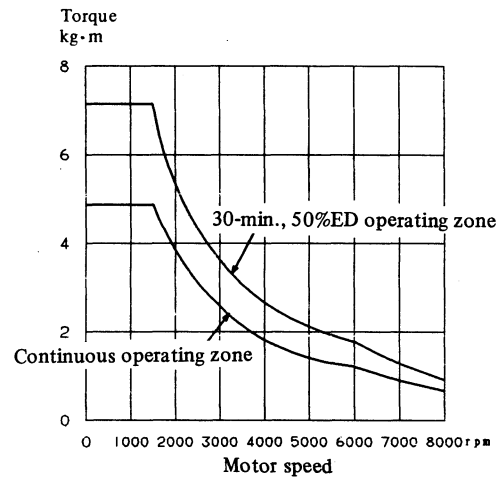
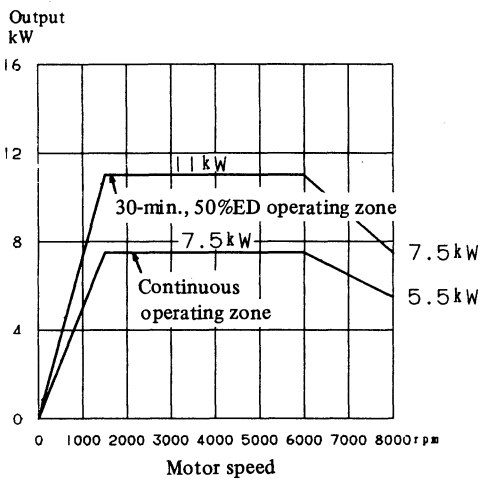

MODEL 12S/8000

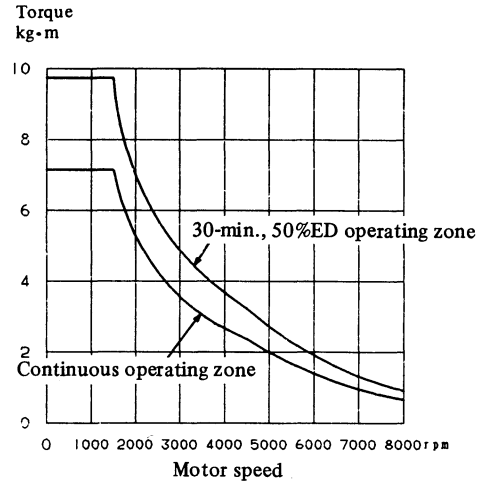
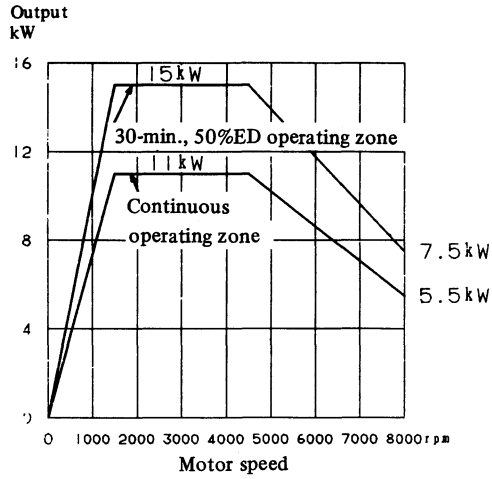

MODEL 15S/8000

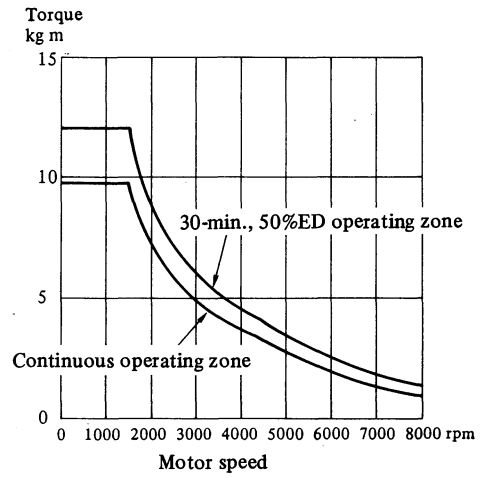
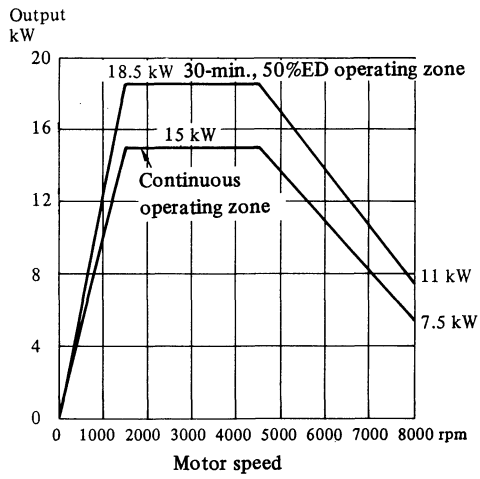

MODEL 18S/6000

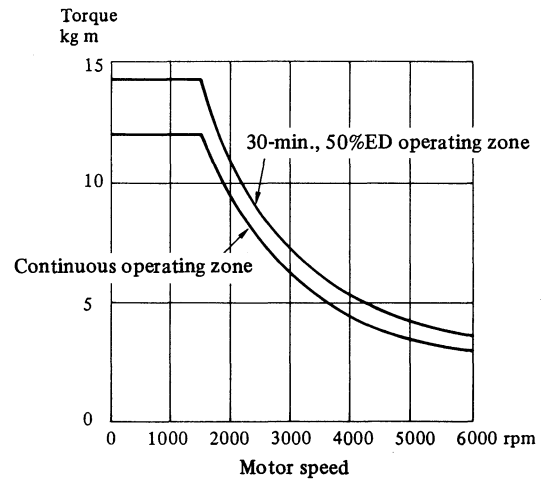
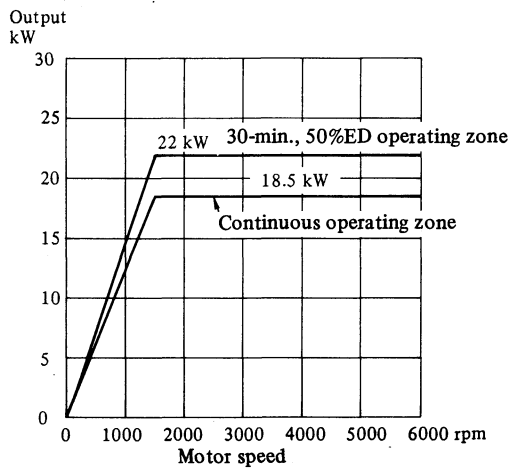

MODEL 22S/6000

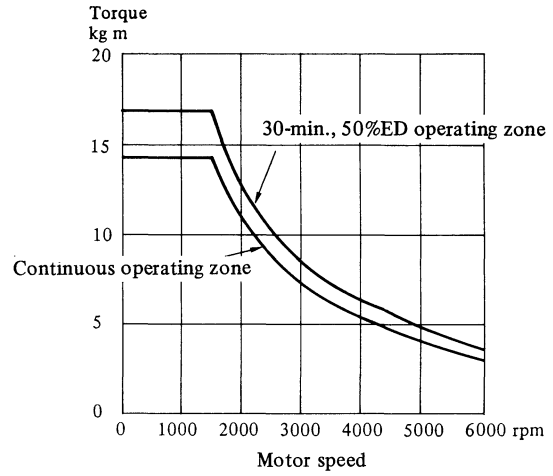
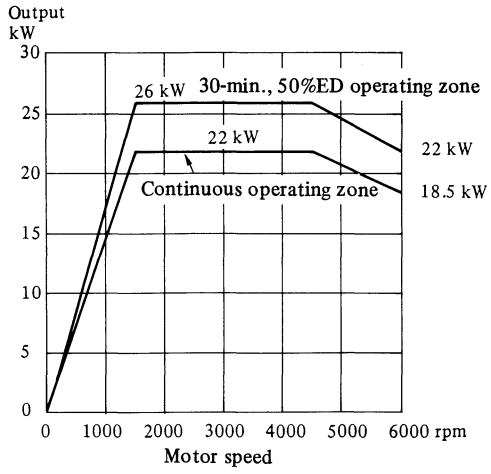

4. CONFIGURATION AND ORDER SPECIFICATION DRAWING NUMBER

4.1 Configuration

The AC spindle motor comprises the motor and accessories.

- (1) AC spindle motor (basic)
- (2) Key (accessory)
- (3) Signal connector (housing, contactor) (accessory)

The accessories are stored in the terminal box.

The specifications of the connection cables between the motor and the AC spindle servo unit are described in the Appendix 1 of this manual. The cables should be prepared by the MTB.

4.2 Order Specification Drawing Number

1) AC spindle motor S series

Nomenclature		Spec. Dwg. No	Remarks
Model 1S	Flange mounting	A06B-0750-B100	Exhaust rear
		A06B-0750-B101	Exhaust front
	Foot mounting	A06B-0750-B200	Exhaust rear
		A06B-0750-B201	Exhaust front
Model 1.5S	Flange mounting	A06B-0751-B100	Exhaust rear
		A06B-0751-B101	Exhaust front
	Foot mounting	A06B-0751-B200	Exhaust rear
		A06B-0751-B201	Exhaust front
Model 2S	Flange mounting	A06B-0752-B100	Exhaust rear
		A06B-0752-B101	Exhaust front
	Foot mounting	A06B-0752-B200	Exhaust rear
		A06B-0752-B201	Exhaust front
Model 3S	Flange mounting	A06B-0753-B100	Exhaust rear
		A06B-0753-B101	Exhaust front
	Foot mounting	A06B-0753-B200	Exhaust rear
		A06B-0753-B201	Exhaust front
Model 6S	Flange mounting	A06B-0754-B100	Exhaust rear
		A06B-0754-B101	Exhaust front
	Foot mounting	A06B-0754-B200	Exhaust rear
		A06B-0754-B201	Exhaust front

Nomenclature		Spec. Dwg. No	Remarks
Model 8S	Flange mounting	A06B-0755-B100	4500rpm, Exhaust rear
		A06B-0755-B101	4500rpm, Exhaust front
	Foot mounting	A06B-0755-B200	4500rpm, Exhaust rear
		A06B-0755-B201	4500rpm, Exhaust front
	Flange mounting	A06B-0755-B100#0100	6000rpm, Exhaust rear
		A06B-0755-B101#0100	6000rpm, Exhaust front
	Foot mounting	A06B-0755-B200#0100	6000rpm, Exhaust rear
		A06B-0755-B201#0100	6000rpm, Exhaust front
Model 12S	Flange mounting	A06B-0756-B100	4500rpm, Exhaust rear
		A06B-0756-B101	4500rpm, Exhaust front
	Foot mounting	A06B-0756-B200	4500rpm, Exhaust rear
		A06B-0756-B201	4500rpm, Exhaust front
	Flange mounting	A06B-0756-B100#0100	6000rpm, Exhaust rear
		A06B-0756-B101#0100	6000rpm, Exhaust front
	Foot mounting	A06B-0756-B200#0100	6000rpm, Exhaust rear
		A06B-0756-B201#0100	6000rpm, Exhaust front
Model 15S	Flange mounting	A06B-0757-B100	4500rpm, Exhaust rear
		A06B-0757-B101	4500rpm, Exhaust front
	Foot mounting	A06B-0757-B200	4500rpm, Exhaust rear
		A06B-0757-B201	4500rpm, Exhaust front
	Flange mounting	A06B-0757-B100#0100	6000rpm, Exhaust rear
		A06B-0757-B101#0100	6000rpm, Exhaust front
	Foot mounting	A06B-0757-B200#0100	6000rpm, Exhaust rear
		A06B-0757-B201#0100	6000rpm, Exhaust front

Nomenclature		Spec. Dwg. No	Remarks
Model 18S	Flange mounting	A06B-0758-B100	Exhaust rear
		A06B-0758-B101	Exhaust front
	Foot mounting	A06B-0758-B200	Exhaust rear
		A06B-0758-B201	Exhaust front
Model 22S	Flange mounting	A06B-0759-B100	Exhaust rear
		A06B-0759-B101	Exhaust front
	Foot mounting	A06B-0759-B200	Exhaust rear
		A06B-0759-B201	Exhaust front

2) AC spindle motor S series (high-speed model)

AC spindle motor S series (High-speed model)

Name		Spec. No.	Remarks
Model 1S/15000	Flange mounting	A06B-0750-B104	15000rpm, has key, no oil seal, exhaust rear
		A06B-0750-B194	15000rpm, has key, no oil seal, exhaust rear
		A06B-0750-B105	15000rpm, has key, no oil seal, exhaust front
		A06B-0750-B195	15000rpm, has key, no oil seal, exhaust front
		A06B-0750-B304	15000rpm, no key, no oil seal, exhaust rear
		A06B-0750-B394	15000rpm, no key, no oil seal, exhaust rear
		A06B-0750-B305	15000rpm, no key, no oil seal, exhaust front
		A06B-0750-B395	15000rpm, no key, no oil seal, exhaust front
Model 2S/15000	Flange mounting	A06B-0752-B104	15000rpm, has key, no oil seal, exhaust rear
		A06B-0752-B194	15000rpm, has key, no oil seal, exhaust rear
		A06B-0752-B105	15000rpm, has key, no oil seal, exhaust front
		A06B-0752-B195	15000rpm, has key, no oil seal, exhaust front
		A06B-0752-B304	15000rpm, no key, no oil seal, exhaust rear
		A06B-0752-B394	15000rpm, no key, no oil seal, exhaust rear
		A06B-0752-B305	15000rpm, no key, no oil seal, exhaust front
		A06B-0752-B395	15000rpm, no key, no oil seal, exhaust front

Name		Spec. No.	Remarks
Model 3S/12000	Flange mounting	A06B-0753-B104	12000rpm, has key, no oil seal, exhaust rear
		A06B-0753-B194	12000rpm, has key, no oil seal, exhaust rear
		A06B-0753-B105	12000rpm, has key, no oil seal, exhaust front
		A06B-0753-B195	12000rpm, has key, no oil seal, exhaust front
		A06B-0753-B304	12000rpm, no key, no oil seal, exhaust rear
		A06B-0753-B394	12000rpm, no key, no oil seal, exhaust rear
		A06B-0753-B305	12000rpm, no key, no oil seal, exhaust front
		A06B-0753-B395	12000rpm, no key, no oil seal, exhaust front
Model 6S/12000	Flange mounting	A06B-0754-B104	12000rpm, has key, no oil seal, exhaust rear
		A06B-0754-B194	12000rpm, has key, no oil seal, exhaust rear
		A06B-0754-B105	12000rpm, has key, no oil seal, exhaust front
		A06B-0754-B195	12000rpm, has key, no oil seal, exhaust front
		A06B-0754-B304	12000rpm, no key, no oil seal, exhaust rear
		A06B-0754-B394	12000rpm, no key, no oil seal, exhaust rear
		A06B-0754-B305	12000rpm, no key, no oil seal, exhaust front
		A06B-0754-B395	12000rpm, no key, no oil seal, exhaust front
Model 8S/8000	Flange mounting	A06B-0755-B104	8000rpm, has key, no oil seal, exhaust rear
		A06B-0755-B194	8000rpm, has key, no oil seal, exhaust rear
		A06B-0755-B105	8000rpm, has key, no oil seal, exhaust front
		A06B-0755-B195	8000rpm, has key, no oil seal, exhaust front
		A06B-0755-B304	8000rpm, no key, no oil seal, exhaust rear
		A06B-0755-B394	8000rpm, no key, no oil seal, exhaust rear
		A06B-0755-B305	8000rpm, no key, no oil seal, exhaust front
		A06B-0755-B395	8000rpm, no key, no oil seal, exhaust front

Name		Spec. No.	Remarks
Model 12S/8000	Flange mounting	A06B-0756-B104	8000rpm, has key, no oil seal, exhaust rear
		A06B-0756-B194	8000rpm, has key, no oil seal, exhaust rear
		A06B-0756-B105	8000rpm, has key, no oil seal, exhaust front
		A06B-0756-B195	8000rpm, has key, no oil seal, exhaust front
		A06B-0756-B304	8000rpm, no key, no oil seal, exhaust rear
		A06B-0756-B394	8000rpm, no key, no oil seal, exhaust rear
		A06B-0756-B305	8000rpm, no key, no oil seal, exhaust front
		A06B-0756-B395	8000rpm, no key, no oil seal, exhaust front
Model 15S/8000	Flange mounting	A06B-0757-B104	8000rpm, has key, no oil seal, exhaust rear
		A06B-0757-B194	8000rpm, has key, no oil seal, exhaust rear
		A06B-0757-B105	8000rpm, has key, no oil seal, exhaust front
		A06B-0757-B195	8000rpm, has key, no oil seal, exhaust front
		A06B-0757-B304	8000rpm, no key, no oil seal, exhaust rear
		A06B-0757-B394	8000rpm, no key, no oil seal, exhaust rear
		A06B-0757-B305	8000rpm, no key, no oil seal, exhaust front
		A06B-0757-B395	8000rpm, no key, no oil seal, exhaust front
Model 18S/6000	Flange mounting	A06B-0758-B100#0100	6000rpm, has key, no oil seal, exhaust rear
		A06B-0758-B190#0100	6000rpm, has key, no oil seal, exhaust rear
		A06B-0758-B101#0100	6000rpm, has key, no oil seal, exhaust front
		A06B-0758-B191#0100	6000rpm, has key, no oil seal, exhaust front
		A06B-0758-B300#0100	6000rpm, no key, no oil seal, exhaust rear
		A06B-0758-B390#0100	6000rpm, no key, no oil seal, exhaust rear
		A06B-0758-B301#0100	6000rpm, no key, no oil seal, exhaust front
		A06B-0758-B391#0100	6000rpm, no key, no oil seal, exhaust front

Name		Spec. No.	Remarks
Model 22S/6000	Flange mounting	A06B-0759-B100#0100	6000rpm, has key, no oil seal, exhaust rear
		A06B-0759-B190#0100	6000rpm, has key, no oil seal, exhaust rear
		A06B-0759-B101#0100	6000rpm, has key, no oil seal, exhaust front
		A06B-0759-B191#0100	6000rpm, has key, no oil seal, exhaust front
		A06B-0759-B300#0100	6000rpm, no key, no oil seal, exhaust rear
		A06B-0759-B390#0100	6000rpm, no key, no oil seal, exhaust rear
		A06B-0759-B301#0100	6000rpm, no key, no oil seal, exhaust front
		A06B-0759-B391#0100	6000rpm, no key, no oil seal, exhaust front

5. CONNECTIONS

Models 1S - 22S

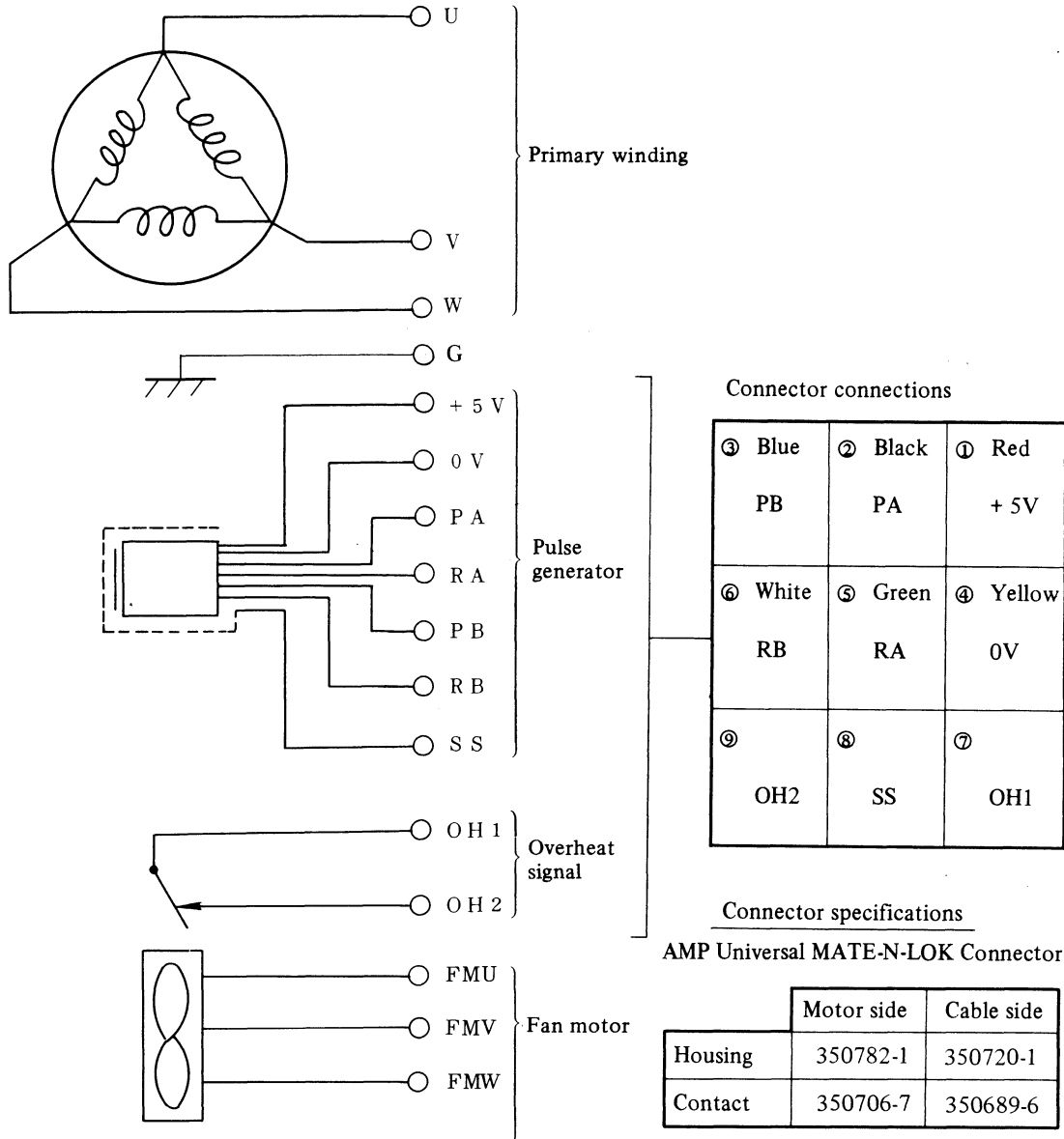

The pulse generator and overheat signals are connected to the AMP connector. The others employ screw terminals. The AMP connector and contact are furnished with the motor.

Screw sizes for terminal connections

Model	Terminal name	
	U, V, W, G	FMU - FMW
1S - 15S	M5	M4
18S - 22S	M8	M4

6. CAUTIONS IN USE

1) Terminal box

a) Models 1S - 15S

The plastic terminal box is newly employed, and the conventional metallic side plate is now eliminated. Directly mount the conduit connector using the nut as shown below.

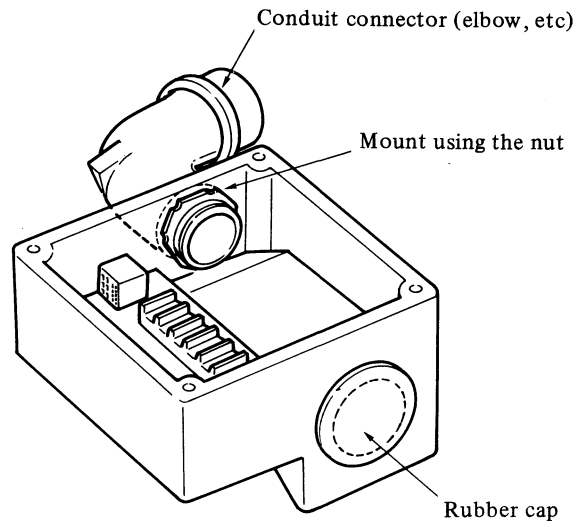

b) Models 18S, 22S

Construction is same as that of conventional types.

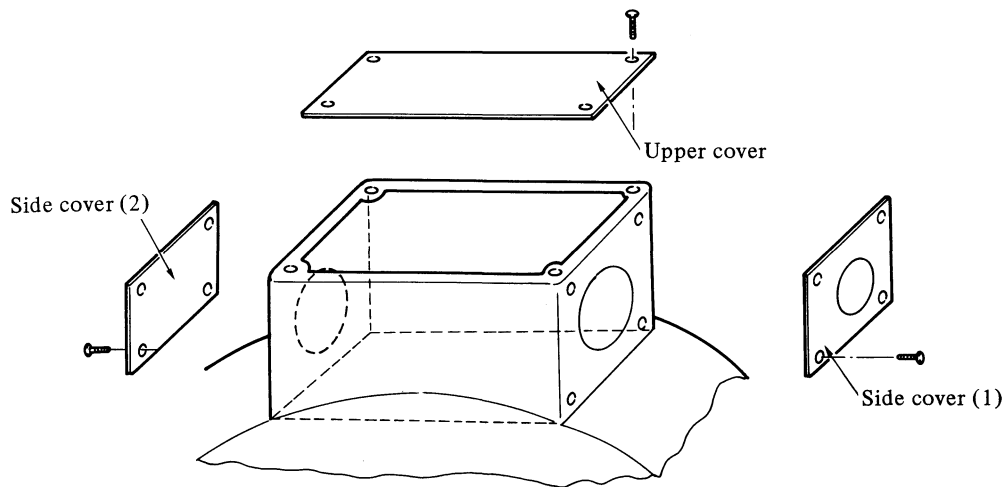

Pull out the cable through the hole on the side plate (1).
Cable can be routed through either right or left side by changing the side plates (1) and (2) with each other.

2) Allowable radial load

Use the motor output shaft below the allowable radial loads shown in the table below. For high-speed models, refer to the list of specifications.

Motor model	Allowable radial load	Output shaft side bearing
Model 1S	40 kg	6206
Model 1.5S	90 kg	
Model 2S	90 kg	6208
Model 3S	150 kg	
Model 6S	200 kg	6308
Model 8S	300 kg	6210
Model 12S, 15S	300 kg	6312
Model 18S, 22S	450 kg	

Note) The above allowable radial load is a value obtained by applying load at the end of the output shaft. When the center of belt tension is out of the output shaft end, the allowable radial load becomes smaller than the above value.

When using belt to transmit power, adjust the tension so that it does not exceed the above allowable value. In case load is applied in the thrust direction by helical gears, the shaft will move in the thrust direction. Therefore, do not apply thrust load as a rule.

3) Mount the motor so that cutting oil or lubricating oil is not directly splashed to the motor main body.

4) Dynamic balance

The motor rotor is dynamically balanced with the balancing machine under the mounting condition of a half key (1/2 the key thickness shown in the outer dimensions drawing) keyed on the shaft.

Since the AC spindle motor is a high-speed rotating motor, its slightest unbalance causes noticeable vibrations. Pay particular attention to dynamic balance of motor shaft gears and pulleys as well as other high-speed rotating shafts.

For high-speed operation, use a keyless motor.

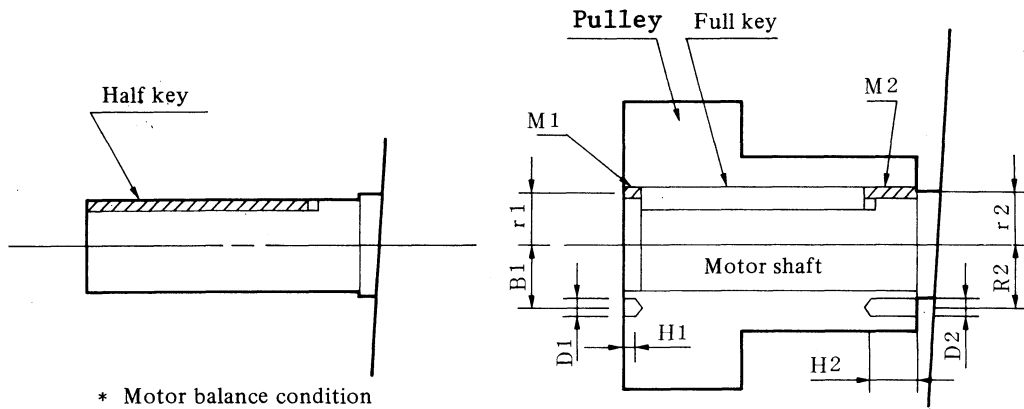

* Motor balance condition

$$\pi (D1/2)^2 H1 \cdot p \times R1 = M1 \times r1 \quad p; \text{ Density}$$

$$\pi (D2/2)^2 H2 \cdot p \times R2 = M2 \times r2$$

* Balance correction

- 5) An oil seal is mounted to the flange type motor output shaft. Keep the lubricating oil level lower than the oil seal lip, so that lubricating oil will not spill straight on the lip. Since the seal effect may be lost with lubricating oil spilled directly on the lip even in forced lubrication, mount a fringer as illustrated below.

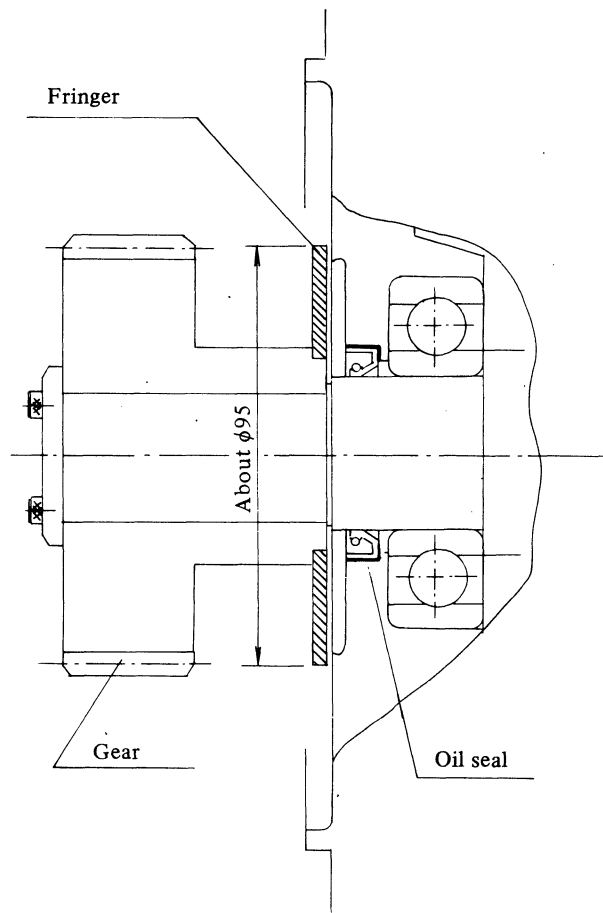

Fringer mounting example

- 6) Points to be noted when the AC spindle motor is used in a dry environment
The seal effect, regarding the oil seal which is mounted in the front flange section of the flange type, is activated in the state where the lubricating oil is distributed on the flange surface in the same manner as inside an oil lubricated gear box. However, if it is rotated at high speed in the state where the lubricating oil has not been distributed by the belt drive, etc. (dry state), a shrill sound may be emitted from the contact section of the oil seal and the shaft. In this case, the lip section will be damaged, and the coil spring tightening the lip section will slacken off. In order to prevent the above occurrence, when using the AC spindle motor in the dry state, detach the coil spring tightening the lip section and use in a state of reduced friction between the lip and the shaft. Even when the coil spring is detached, there will be no lessening of the dustproof effect for sludge, casting particles, etc.

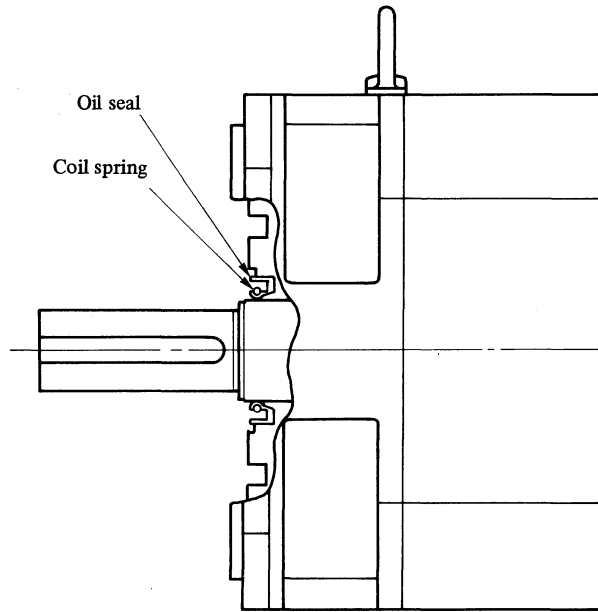

7. EXTERNAL DIMENSIONS

7.1 AC Spindle Motor Model 1S

a) Flange type

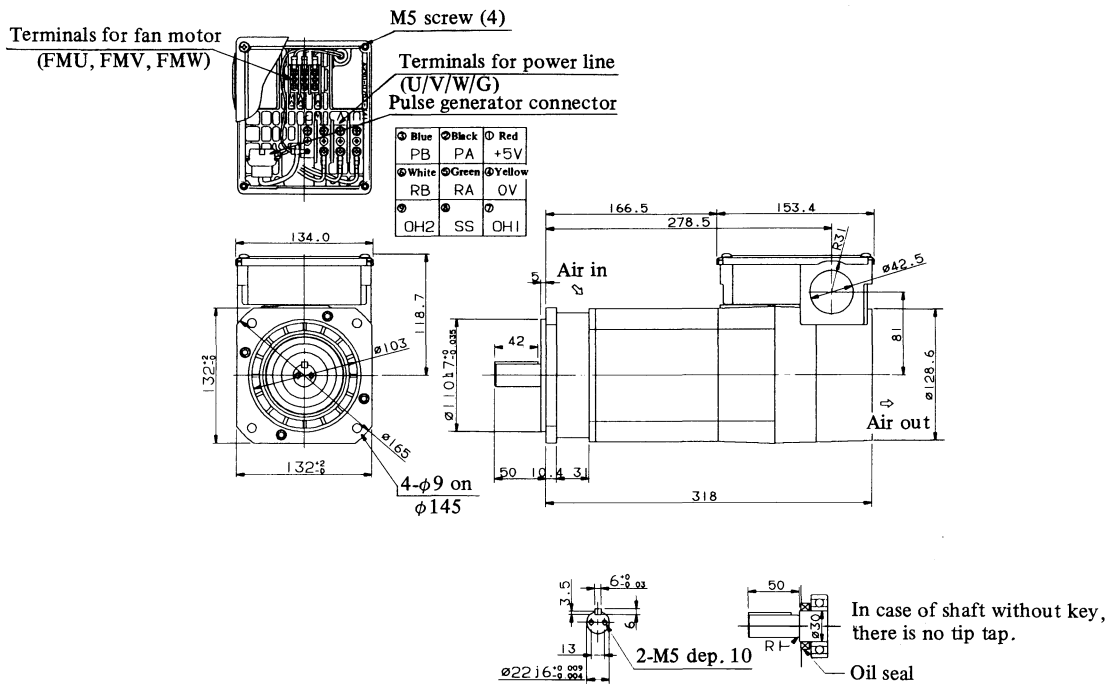

- (Note)
1. The output shaft should be horizontal or vertical downward in use.
 2. Use hexagon bolts M8, length 20 mm or less as mounting bolts.
 3. The motor in which cooling air flow direction is reversed is also available.

b) Foot mounting type

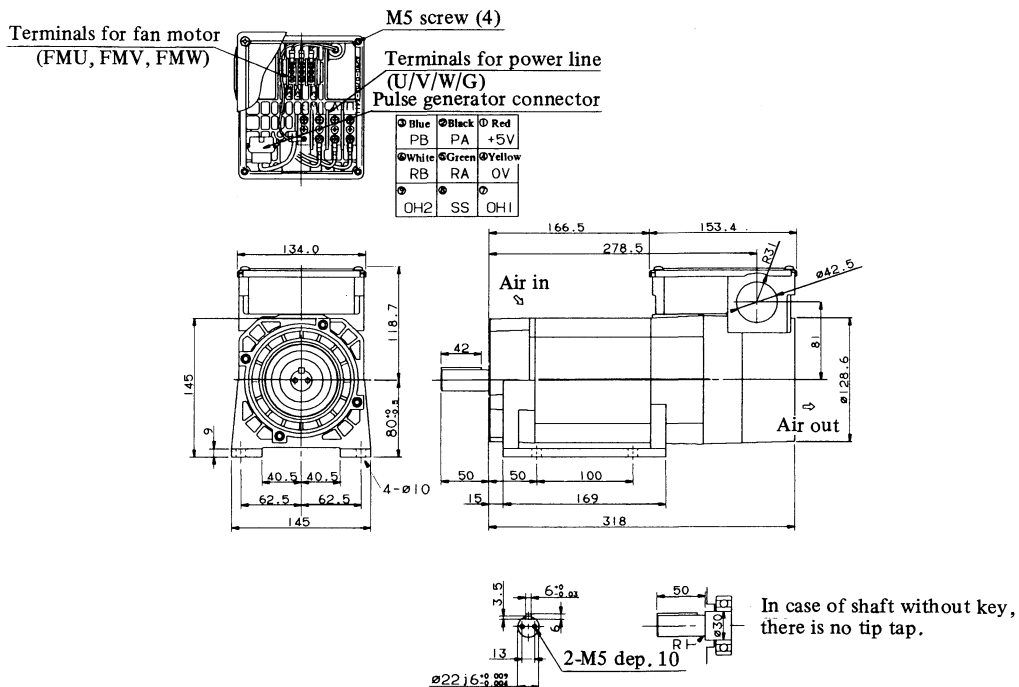

- (Note)
1. The output shaft should be horizontal or vertical downward in use.
 2. Use hexagon bolts M8, length 20 mm or less as mounting bolts.
 3. The motor in which cooling air flow direction is reversed is also available.

7.2 AC Spindle Motor Model 1.5S

a) Flange type

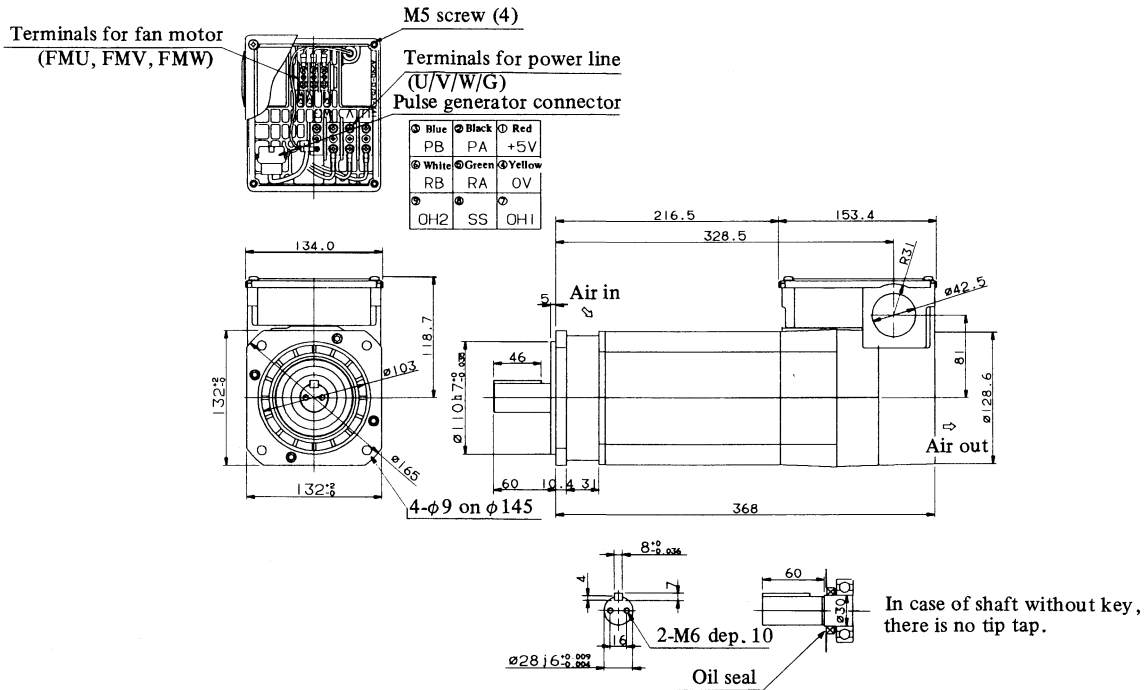

- (Note)
1. The output shaft should be horizontal or vertical downward in use.
 2. Use hexagon bolts M8, length 20 mm or less as mounting bolts.
 3. The motor in which cooling air flow direction is reversed is also available.

b) Foot mounting type

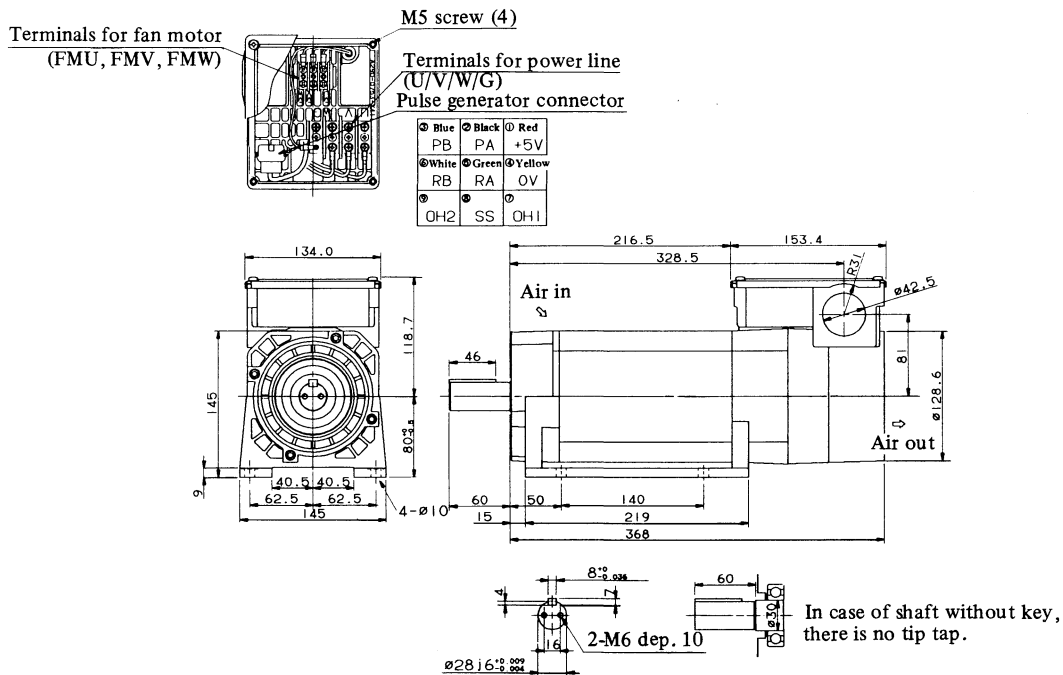

- (Note)
1. The output shaft should be horizontal or vertical downward in use.
 2. Use hexagon bolts M8, length 20 mm or less as mounting bolts.
 3. The motor in which cooling air flow direction is reversed is also available.

7.3 AC Spindle Motor Model 2S

a) Flange type

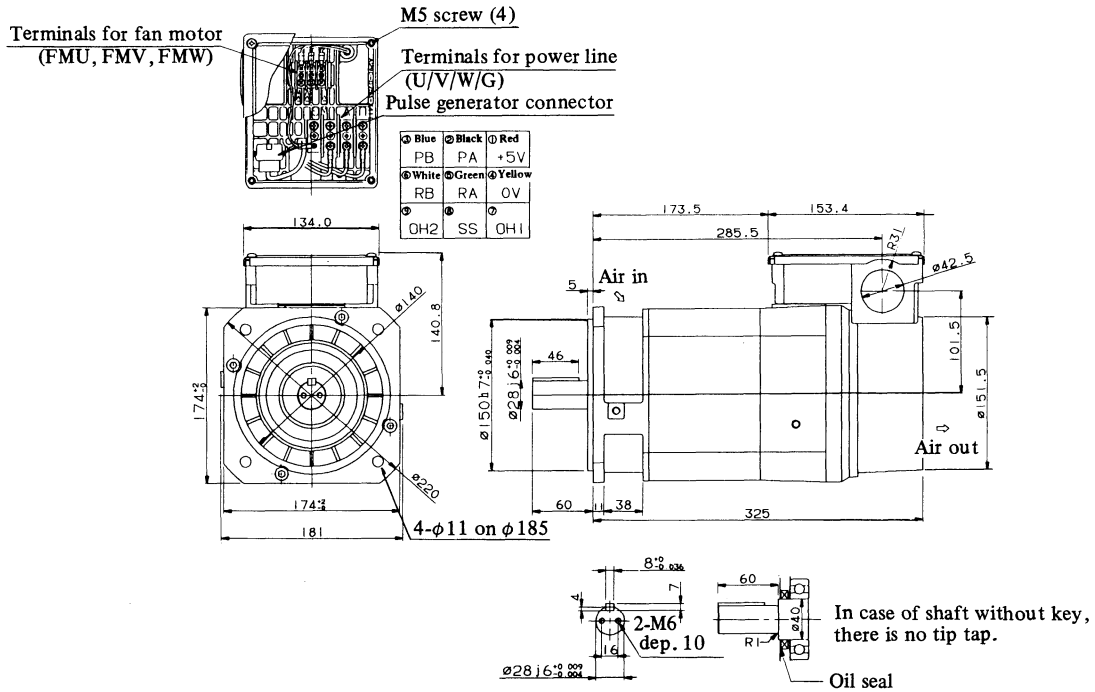

- (Note) 1. The output shaft should be horizontal or vertical downward in use.
 2. Use hexagon bolts M10, length 35 mm or less as mounting bolts.
 3. The motor in which cooling air flow direction is reversed is also available.

b) Foot mounting type

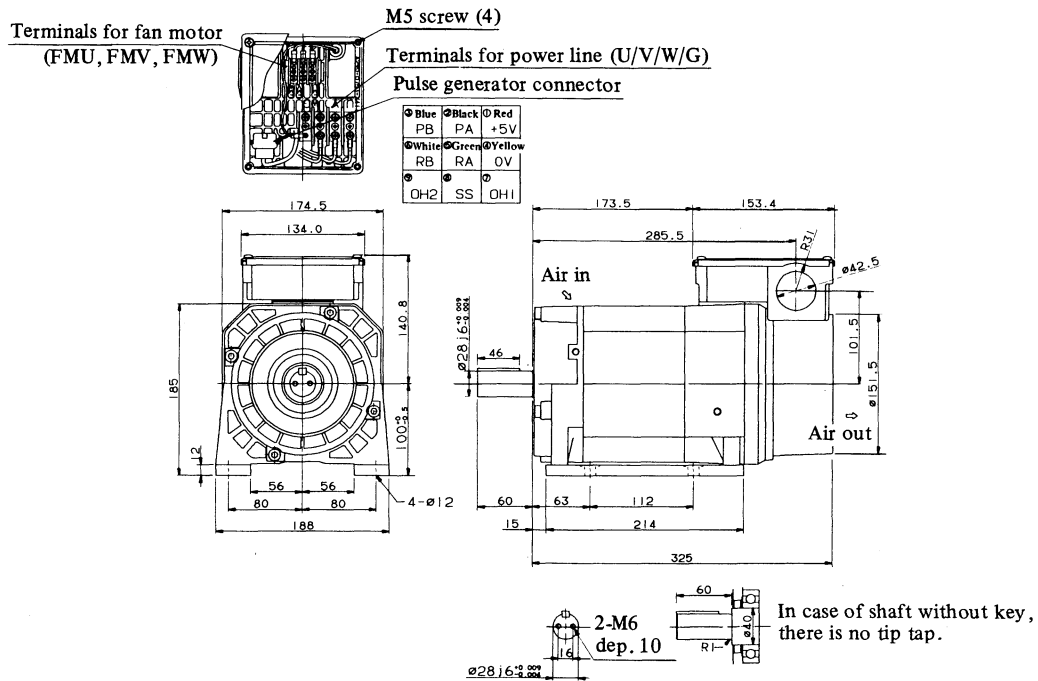

- (Note) 1. The output shaft should be horizontal or vertical downward in use.
 2. Use hexagon bolts M10, length 20 mm or less as mounting bolts.
 3. The motor in which cooling air flow direction is reversed is also available.

7.4 AC Spindle Motor Model 3S

a) Flange type

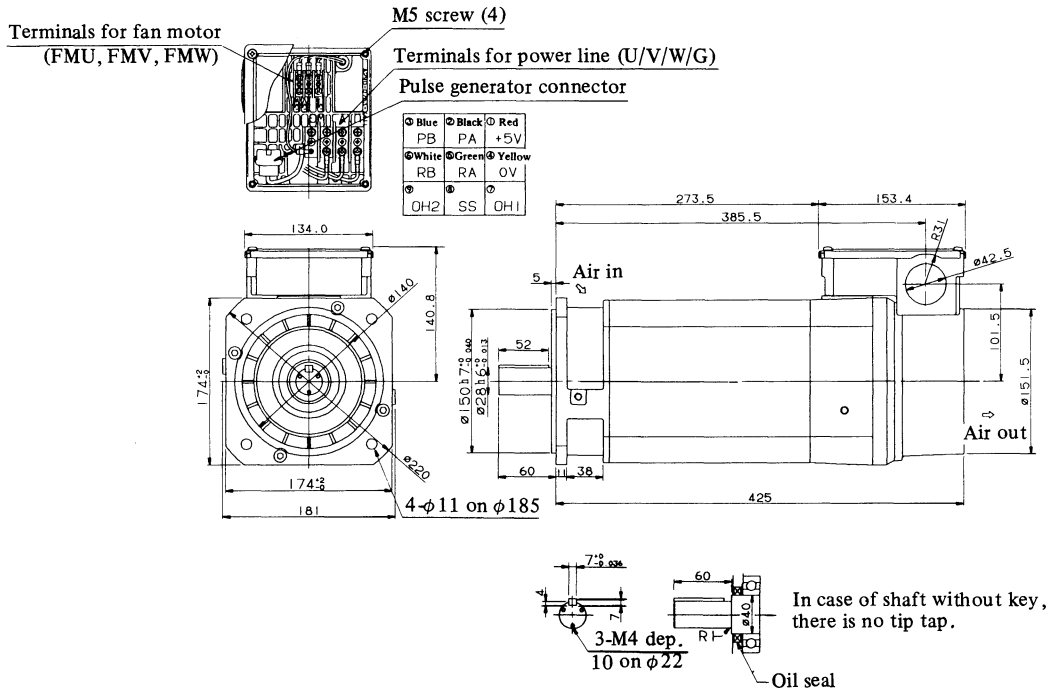

- (Note)
1. The output shaft should be horizontal or vertical downward in use.
 2. Use hexagon bolts M10, length 35 mm or less as mounting bolts.
 3. The motor in which cooling air flow direction is reversed is also available.

b) Foot mounting type

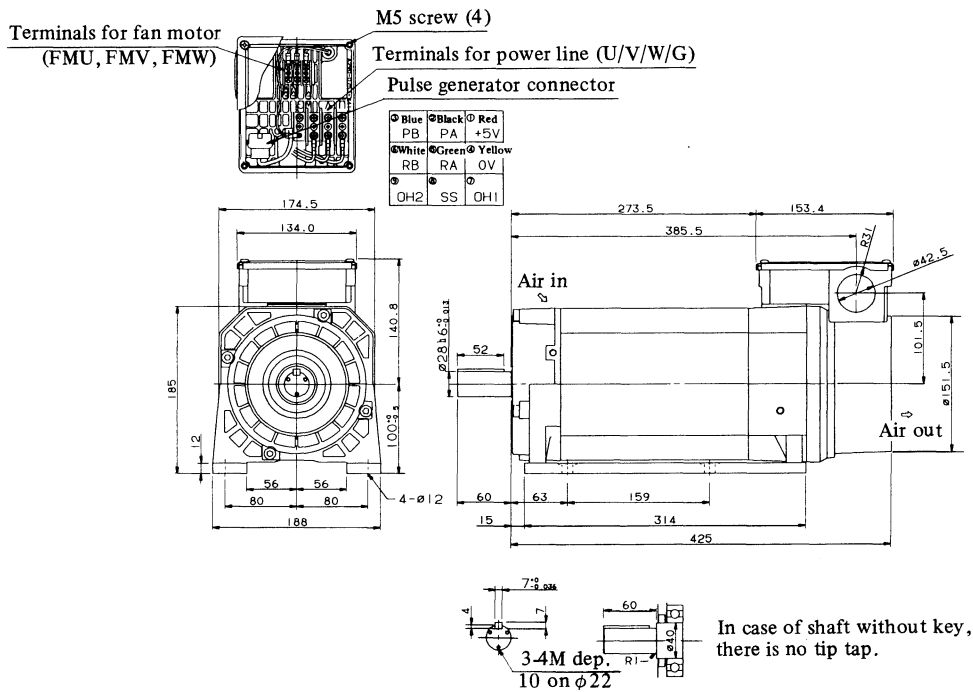

- (Note)
1. The output shaft should be horizontal or vertical downward in use.
 2. Use hexagon bolts M10, length 20 mm or less as mounting bolts.
 3. The motor in which cooling air flow direction is reversed is also available.

7.5 AC Spindle Motor Model 6S

a) Flange type

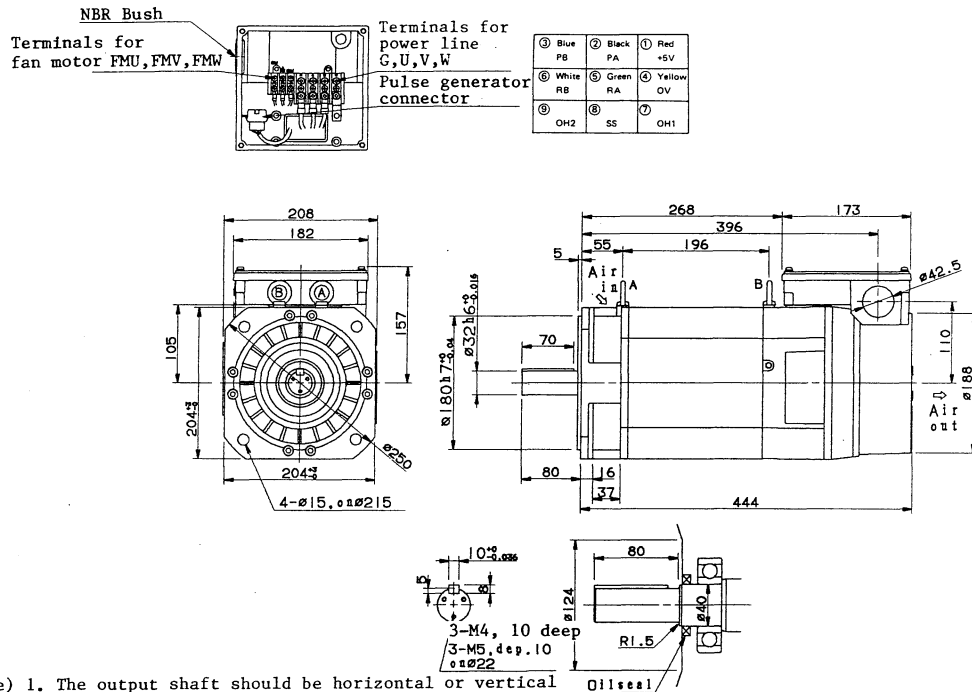

- Note) 1. The output shaft should be horizontal or vertical downward in use.
2. Use hexagon bolts M12, length 40 mm or less as mounting bolts.
3. The motor in which cooling air flow direction is reversed is also available.

b) Foot mounting type

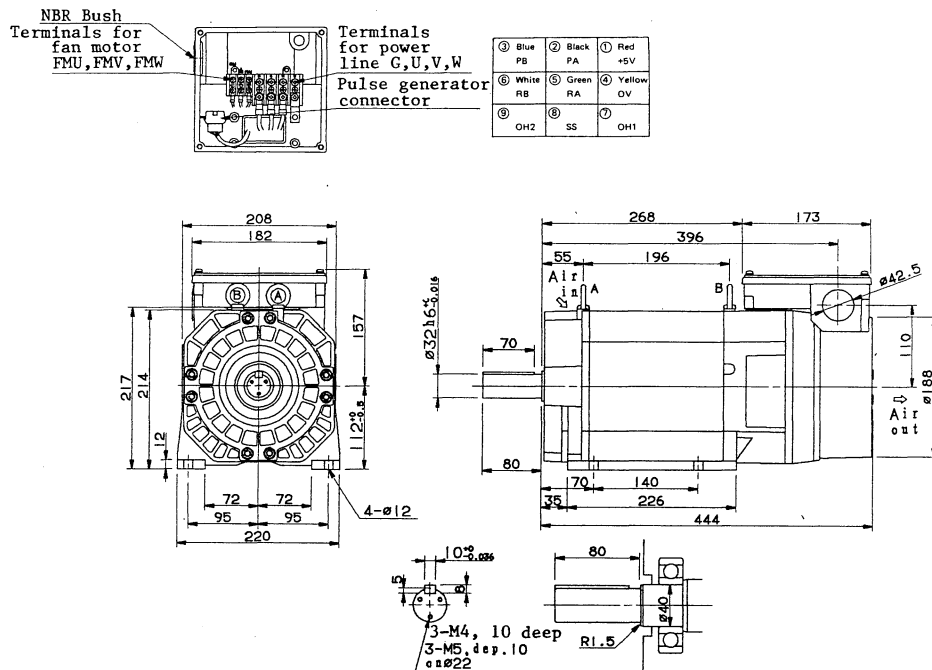

- Note) 1. The output shaft should be horizontal or vertical downward in use.
2. Use hexagon bolts M10, length 30 mm or less as mounting bolts.
3. The motor in which cooling air flow direction is reversed is also available.

7.6 AC Spindle Motor Model 8S

a) Flange type

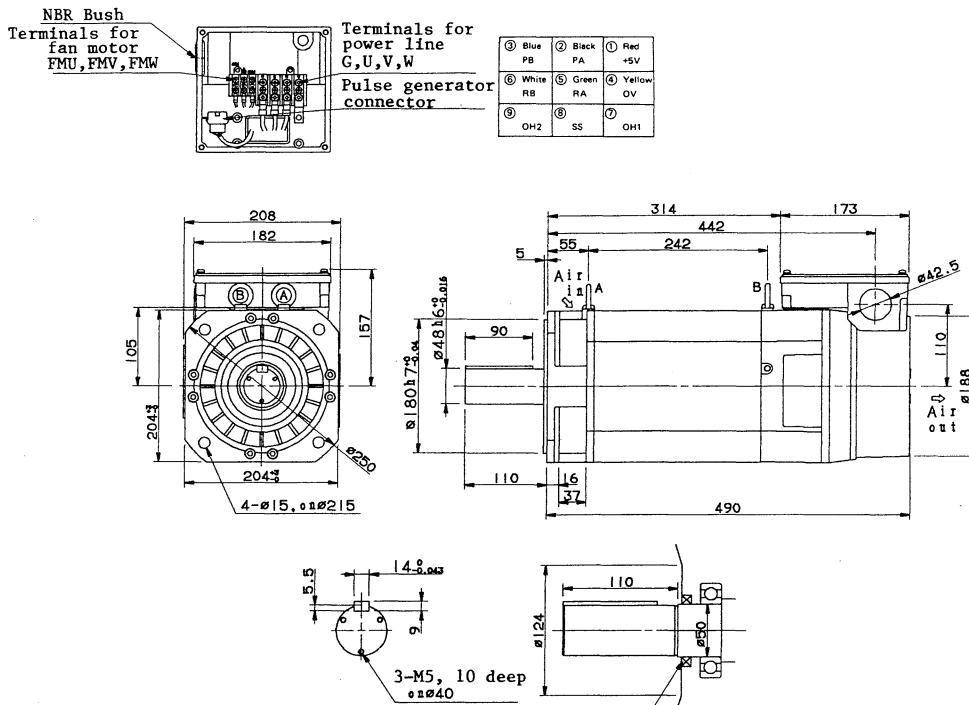

- Note) 1. The output shaft should be horizontal or vertical downward in use.
2. Use hexagon bolts M12, length 40 mm or less as mounting bolts.
3. The motor in which cooling air flow direction is reversed is also available.

b) Foot mounting type

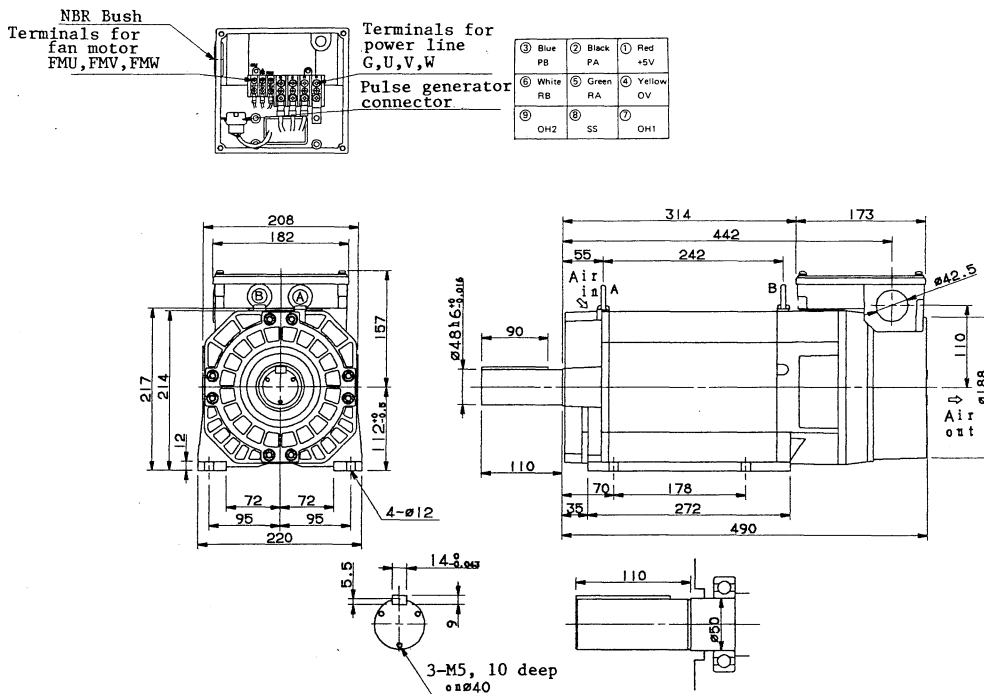

- Note) 1. The output shaft should be horizontal or vertical downward in use.
2. Use hexagon bolts M10, length 30 mm or less as mounting bolts.
3. The motor in which cooling air flow direction is reversed is also available.

7.7 AC Spindle Motor Model 12S, 15S

a) Flange type

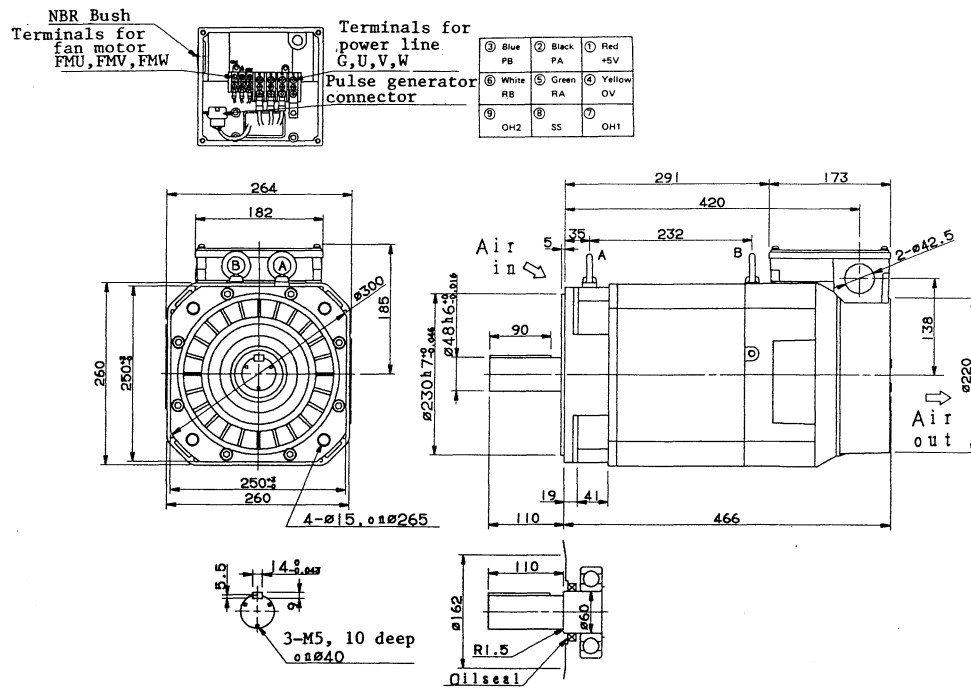

b) Foot mounting type

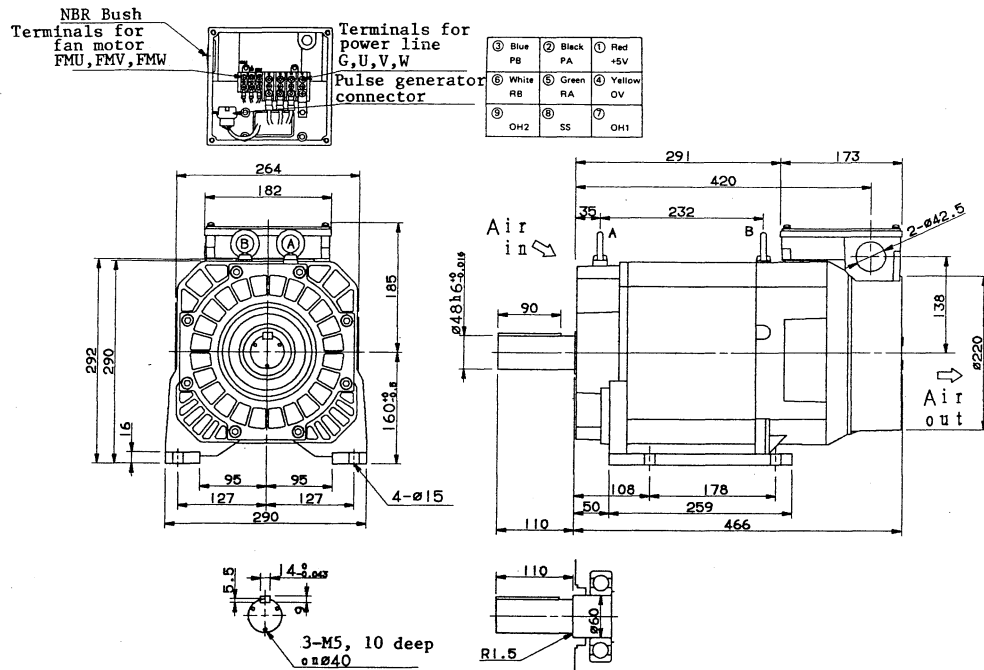

7.8 AC Spindle Motor Model 18S, 22S

a) Flange type

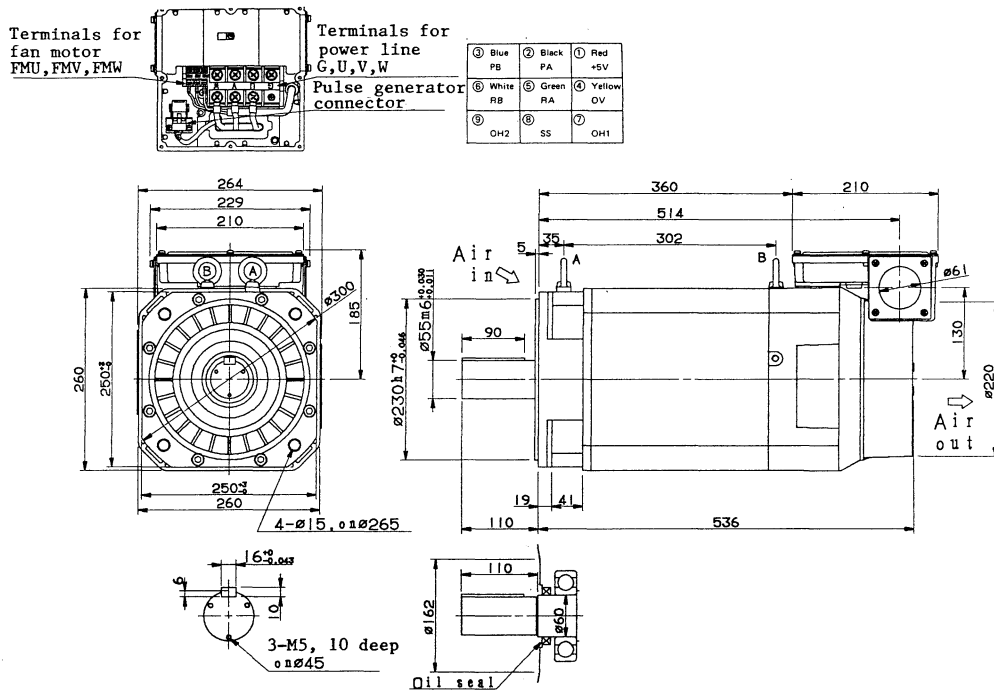

- Note) 1. The output shaft should be horizontal or vertical downward in use.
 2. Use hexagon bolts M12, length 45 mm or less as mounting bolts.
 3. The motor in which cooling air flow direction is reversed is also available.

b) Foot mounting type

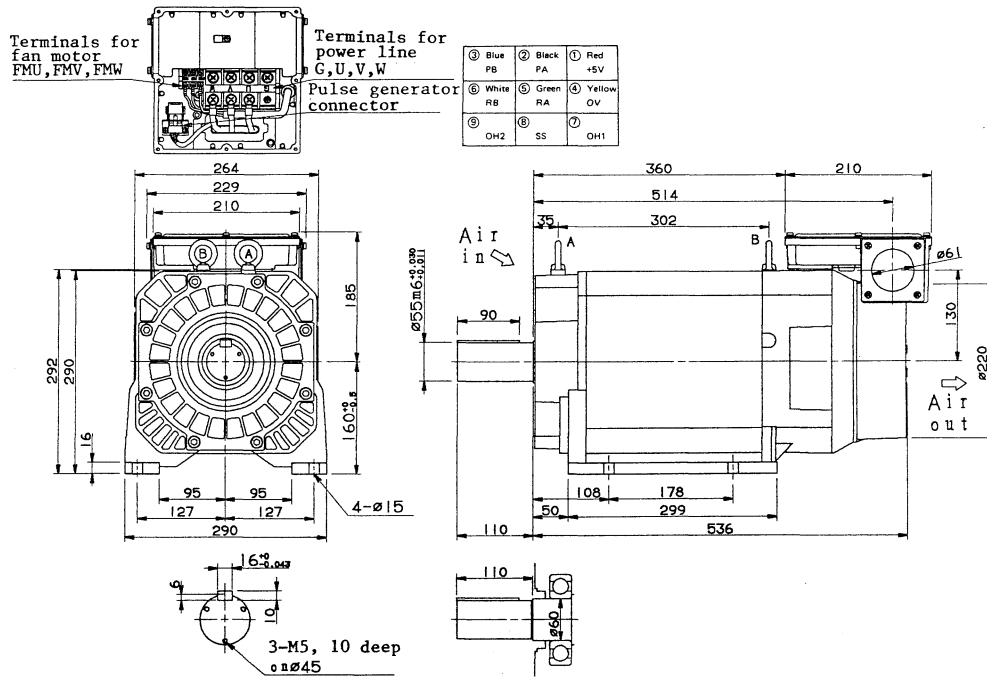

- Note) 1. The output shaft should be horizontal or vertical downward in use.
 2. Use hexagon bolts M12, length 45 mm or less as mounting bolts.
 3. The motor in which cooling air flow direction is reversed is also available.

7.9 AC Spindle Motor Model 1S/15000 (Flange type)

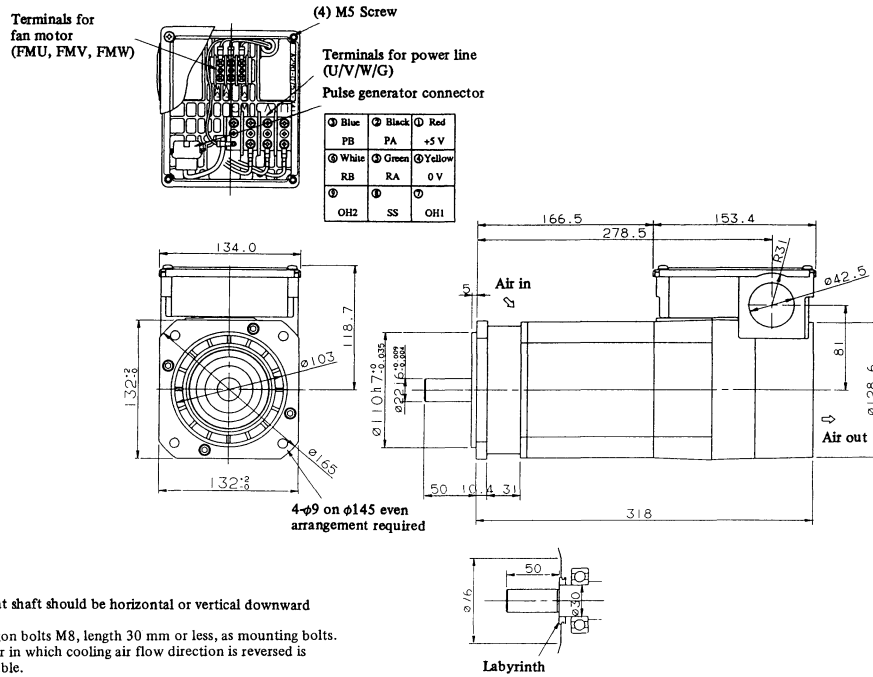

7.10 AC Spindle Motor Model 2S/15000 (Flange type)

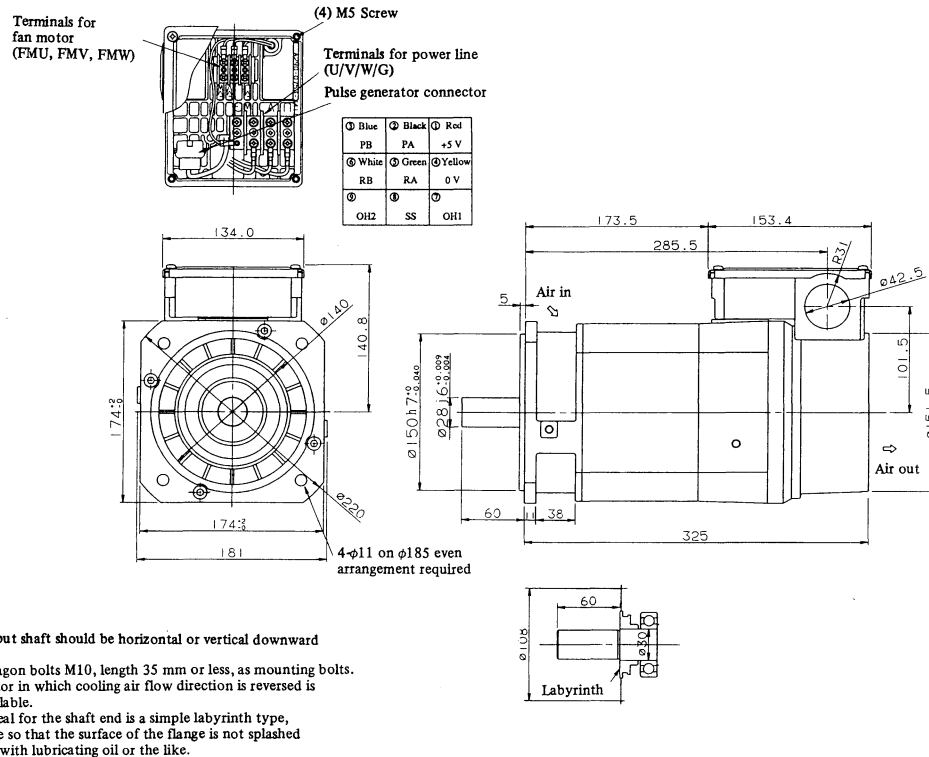

7.11 AC Spindle Motor Model 3S/12000 (Flange type)

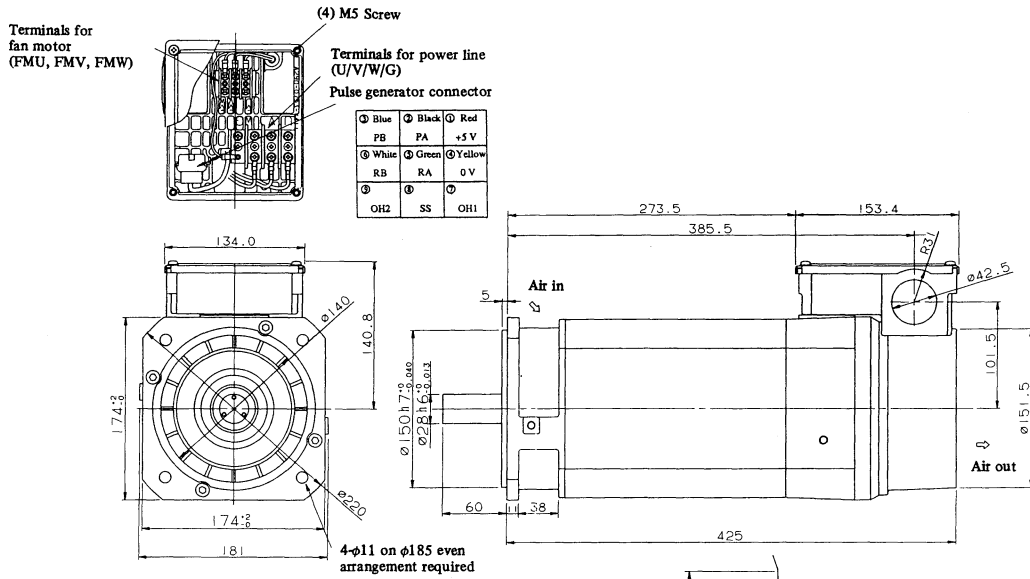

- Note)
1. The output shaft should be horizontal or vertical downward in use.
 2. Use hexagon bolts M10, length 35 mm or less, as mounting bolts.
 3. The motor in which cooling air flow direction is reversed is also available.
 4. As the seal for the shaft end is a simple labyrinth type, take care so that the surface of the flange is not splashed directly with lubricating oil or the like.

7.12 AC Spindle Motor Model 6S/12000 (Flange type)

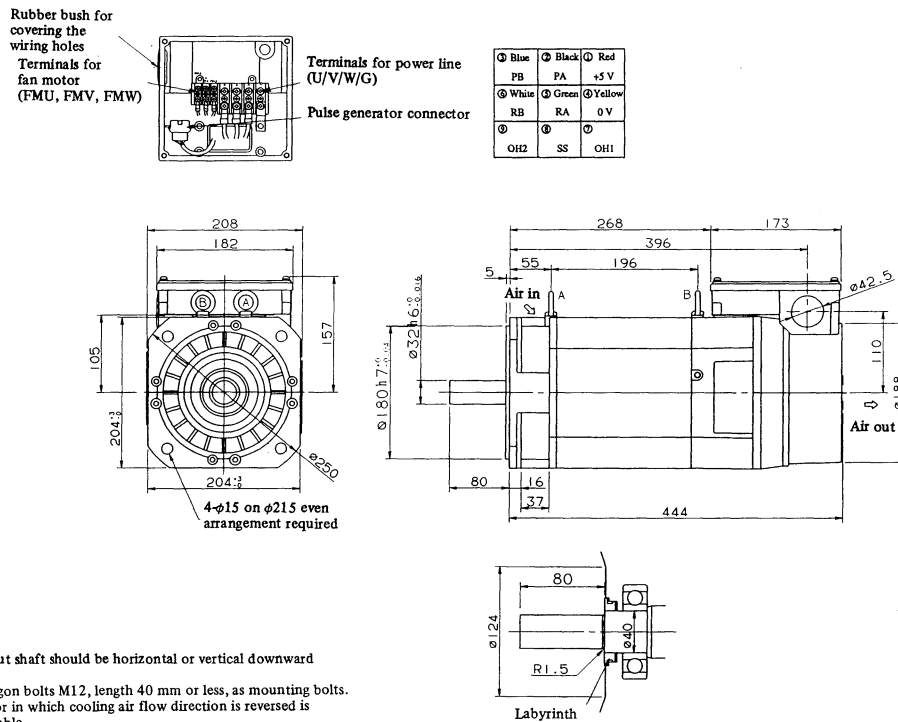

- Note)
1. The output shaft should be horizontal or vertical downward in use.
 2. Use hexagon bolts M12, length 40 mm or less, as mounting bolts.
 3. The motor in which cooling air flow direction is reversed is also available.
 4. As the seal for the shaft end is a simple labyrinth type, take care so that the surface of the flange is not splashed directly with lubricating oil or the like.

7.13 AC Spindle Motor Model 8S/8000 (Flange type)

Rubber bush for covering the wiring holes
Terminals for fan motor (FMU, FMV, FMW)

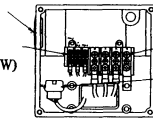

Terminals for power line (U/V/W/G)
Pulse generator connector

⊙ Blue	⊙ Black	⊙ Red
PB	PA	+5 V
⊙ White	⊙ Green	⊙ Yellow
RB	RA	0 V
⊙	⊙	⊙
OH2	SS	OH1

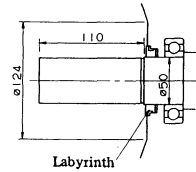
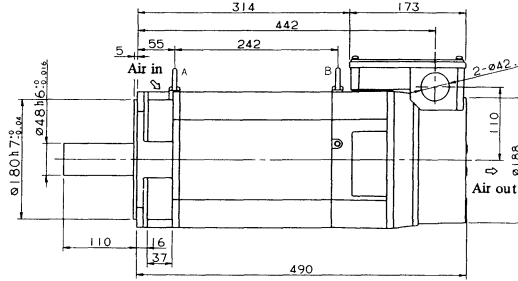
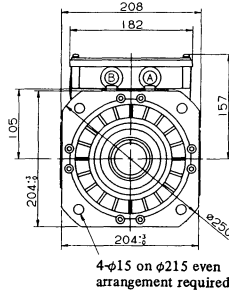

- Note)
1. The output shaft should be horizontal or vertical downward in use.
 2. Use hexagon bolts M12, length 40 mm or less, as mounting bolts.
 3. The motor in which cooling air flow direction is reversed is also available.
 4. As the seal for the shaft end is a simple labyrinth type, take care so that the surface of the flange is not splashed directly with lubricating oil or the like.

7.14 AC Spindle Motor Model 12S/8000, 15S/8000 (Flange type)

Rubber bush for covering the wiring holes
Terminals for fan motor (FMU, FMV, FMW)

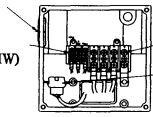

Terminals for power line (U/V/W/G)
Pulse generator connector

⊙ Blue	⊙ Black	⊙ Red
PB	PA	+5 V
⊙ White	⊙ Green	⊙ Yellow
RB	RA	0 V
⊙	⊙	⊙
OH2	SS	OH1

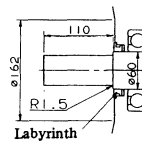
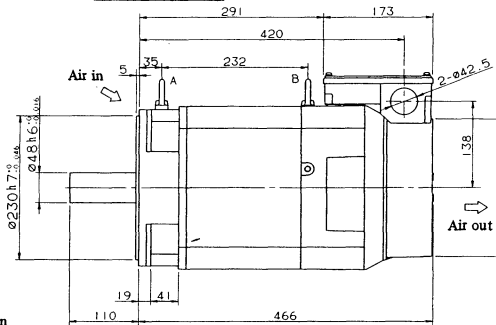
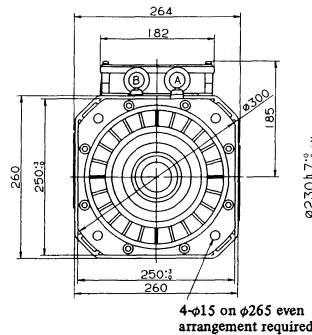

- Note)
1. The output shaft should be horizontal or vertical downward in use.
 2. Use hexagon bolts M12, length 45 mm or less, as mounting bolts.
 3. The motor in which cooling air flow direction is reversed is also available.
 4. As the seal for the shaft end is a simple labyrinth type, take care so that the surface of the flange is not splashed directly with lubricating oil or the like.

7.15 AC Spindle Motor Model 18S/6000, 22S/6000 (Flange type)

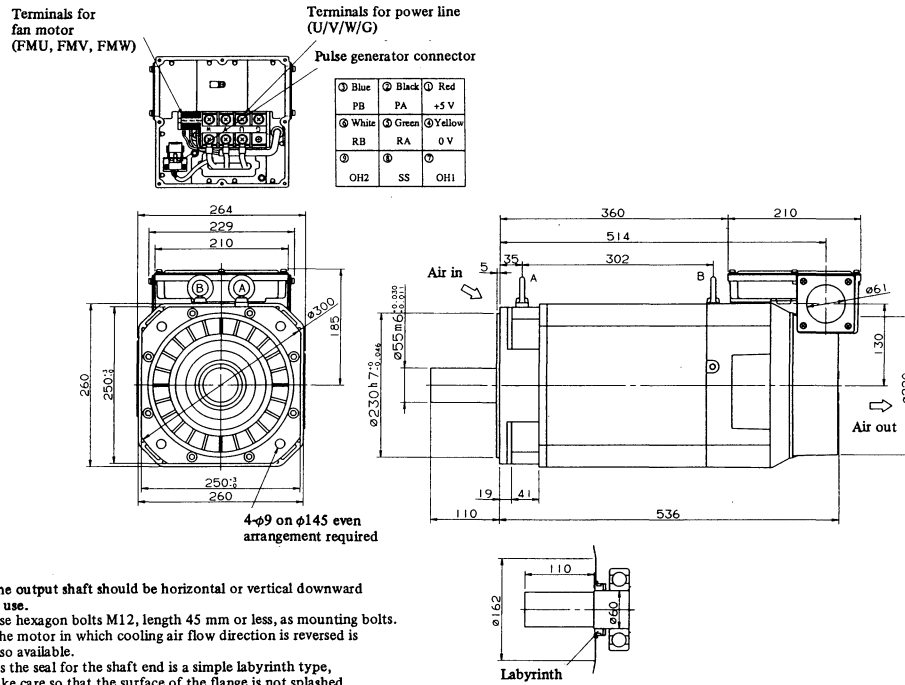

II. AC SPINDLE SERVO UNIT S series

1. GENERAL

The FANUC AC SPINDLE SERVO UNIT S series fully uses the most advanced microprocessor and power electronics technologies to provide stable and smooth drive operation with less vibration and noise from the low speed to the high speed. It has the functions such as regenerative braking control (Patent pending) and electric spindle orientation control (Patent pending) to fully meet the needs of the most advanced CNC machine tools.

2. FEATURES

- 1) The light and compact unit is achieved owing to the plastic case.
- 2) The heat radiation part is cooled by the outside air and the electric circuit in the magnetics cabinet can be completely closed resulting in higher reliability.
- 3) Adoption of a custom LSI and a high-performance processor enhances the motor control performance and flexibility.
- 4) The rigid tapping process involving synchronous feed of the spindle and the Z axis in the machining center is possible.
- 5) Power-saving (energy-saving) design
The spindle servo unit is designed for energy-saving to obtain high power with a small current owing to the unique power factor improvement design in the input part.
- 6) Regenerative braking is possible. (Model 6S - 22S)
The unique driving method (patent pending) allows the motor to serve as a generator during AC spindle motor deceleration so as to return energy to the power source.
- 7) Low noise drive
The unique driving method (patent pending) reduces noises, even if the AC spindle motor is operated at low speed.
- 8) Smooth low-speed rotation
The unique driving method (patent pending) assures very smooth rotation down to low speed.
- 9) Electric spindle orientation control is applicable (option).
Since the spindle orientation can be done pure-electrically, the mechanical section is simplified, and the machine spindle can be composed with high reliability and largely reduced orientation time.
- 10) The load detection signal function is newly added. This function is used to detect the load status of the machine tool spindle. If the load is larger than the specified load, the contact signal is used to reduce the feed motor speed for moving the table and the cutting load, thus preventing the tools from being damaged.

3. CONFIGURATION AND ORDER SPECIFICATION DRAWING NUMBER

3.1 Models 1S - 3S

The AC spindle servo unit S series (Models 1S, 1.5S, 2S and 3S) consist of the following units and components.

- | | | |
|--|----------------|--|
| 1) Spindle control unit | (Basic) | |
| 2) Resistor unit | (Basic) | |
| 3) Fuse (spare) | (Basic) | |
| 4) Connector (for connection) | (Basic) | |
| 5) AC line filter | (Basic option) | * If no power transformer is used, specify accordingly |
| 6) Spindle orientation control circuit | (Option) | |
| 7) Power transformer | (Option) | |

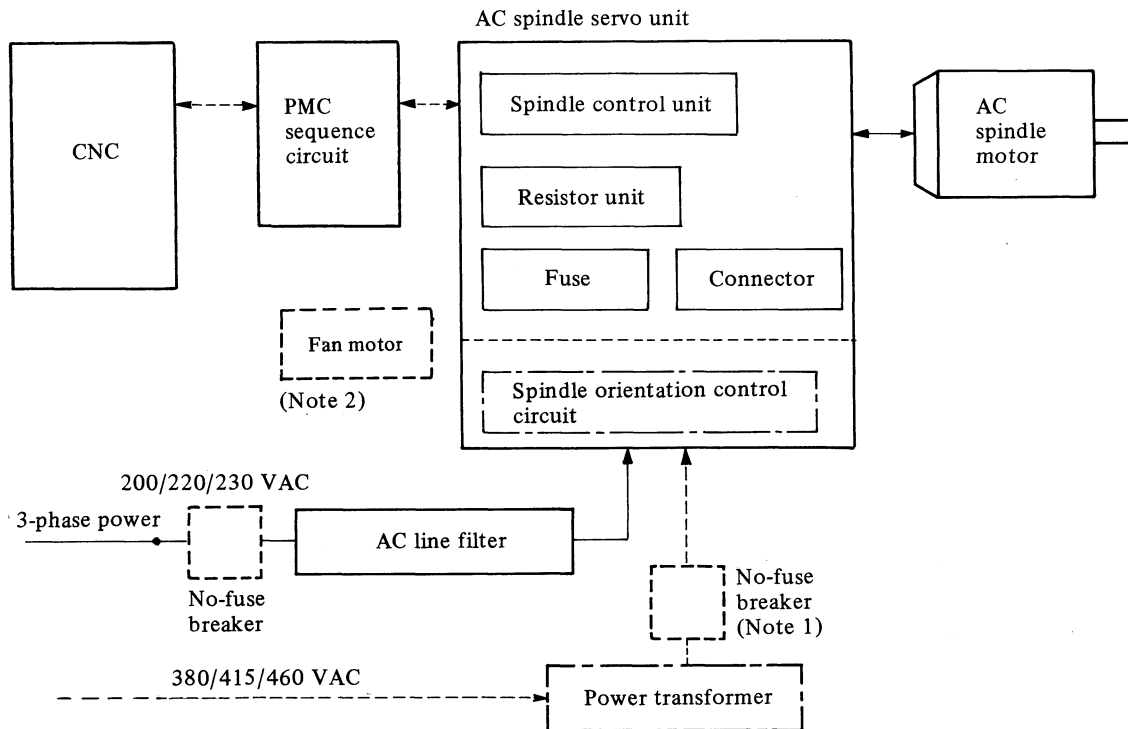

————— : Basic or basic option
 - - - - - : Option
 - - - - - : To be provided by MTB

Note 1) MTB to provide an overcurrent protector with a proper capacity such as a no-fuse breaker to the input power circuit of the AC spindle servo unit S series.

Note 2) Cool the spindle control and resistor units using a fan motor with specified flow.

3.2 Models 6S - 22S

The AC spindle servo unit S series (Models 6S, 8S, 12S, 15S, 18S and 22S) consist of the following units and components.

- 1) Spindle control unit (Basic)
- 2) Fuse (Spare) (Basic)
- 3) Connector (for connection) (Basic)
- 4) Spindle orientation control circuit (Option)
- 5) Speed gain switching circuit (Option)
- 6) Power transformer (Option)
- 7) Unit adaptor (Option)

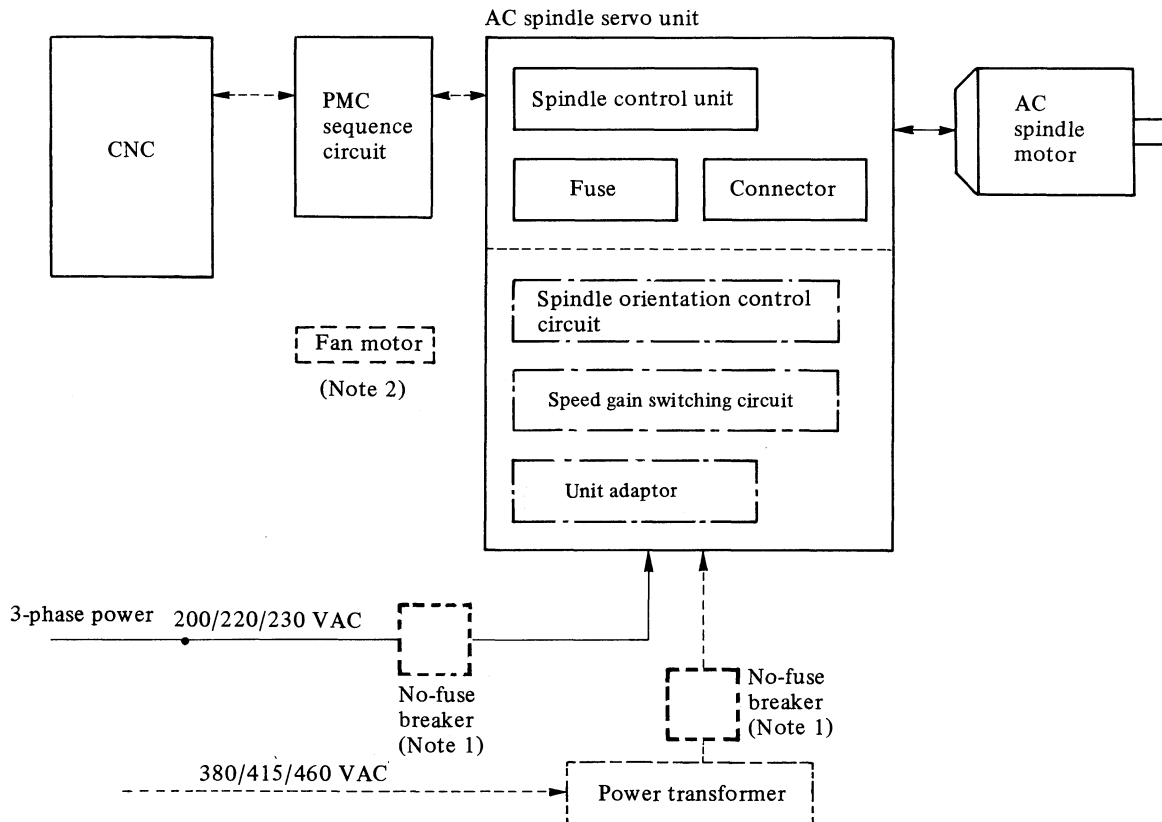

————— : Basic
 - - - - - : Option
 - - - - - : To be provided by MTB

Note 1) MTB to provide an overcurrent protector with a proper capacity such as a no-fuse breaker to the input power circuit of the AC spindle servo unit S series.

Note 2) Provide a fan motor to cool the spindle control unit. When the unit adaptor is used, however, it is not necessary to provide the fan motor.

3.3 Order Specification Drawing Number

3.3.1 Models 1S - 3S, Model 1S/15000, Model 2S/15000 (high-speed model)

Classification	Nomenclature	Spec. Dwg. No.	Remarks	
Basic	Spindle control unit for Model 1S	A06B-6059-H002#H501	External heat radiation type, 8000 rpm	
	Spindle control unit for Model 1.5S	A06B-6059-H002#H508	External heat radiation type, 8000 rpm	
	Spindle control unit for Model 2S	A06B-6059-H002#H502	External heat radiation type, 8000 rpm	
	Spindle control unit for Model 3S	A06B-6059-H002#H503	External heat radiation type, 8000 rpm	
	Spindle control unit for Model 1S/15000	A06B-6059-H002#H509	External heat radiation type, 15000 rpm	
	Spindle control unit for Model 2S/15000	A06B-6059-H002#H505	External heat radiation type, 15000 rpm	
Basic	Connectors	A06B-6059-K101	Soldered type	
		A06B-6059-K102	Crimped type	
	Resistor units	A06B-6052-K050	15Ω	See 4.2.2
		A06B-6052-K051	30Ω x 2 pieces	
	Fuse	A06B-6059-K003		
Basic Option	AC line filter	A81L-0001-0083/3C	Specify if power transformer is not provided.	
Option	Power transformer	A06B-6052-J001	Primary line AC380/415/460V Secondary line AC 200V	

(*1) For optional orientation, refer to the items related to spindle orientation in Part V.

3.3.2 Models 6S - 22S, Models 3S/12000 - 22S/6000 (high-speed model)

Classifi- cation	Nomenclature	Spec. Dwg. No.	Remarks
Basic	Spindle control unit for Model 6S	A06B-6059-H206#H511	External heat radiation type, 6000 rpm
	Spindle control unit for Model 8S	A06B-6059-H208#H512	External heat radiation type, 4500 rpm
		A06B-6059-H208#H513	External heat radiation type, 6000 rpm
	Spindle control unit for Model 12S	A06B-6059-H212#H514	External heat radiation type, 4500 rpm
		A06B-6059-H212#H515	External heat radiation type, 6000 rpm
	Spindle control unit for Model 15S	A06B-6059-H215#H516	External heat radiation type, 4500 rpm
		A06B-6059-H215#H517	External heat radiation type, 6000 rpm
	Spindle control unit for Model 18S	A06B-6059-H218#H518	External heat radiation type, 4500 rpm
	Spindle control unit for Model 22S	A06B-6059-H222#H520	External heat radiation type, 4500 rpm
	Spindle control unit for Model 3S/12000	A06B-6059-H206#H533	External radiation type, 12000 rpm
	Spindle control unit for Model 6S/12000	A06B-6059-H208#H534	External radiation type, 12000 rpm
	Spindle control unit for Model 8S/8000	A06B-6059-H212#H535	External radiation type, 8000 rpm
	Spindle control unit for Model 12S/8000	A06B-6059-H212#H536	External radiation type, 8000 rpm
	Spindle control unit for Model 15S/8000	A06B-6059-H215#H537	External radiation type, 8000 rpm
Spindle control unit for Model 18S/6000	A06B-6059-H218#H519	External radiation type, 6000 rpm	
Spindle control unit for Model 22S/6000	A06B-6059-H222#H521	External radiation type, 6000 rpm	

Classification	Nomenclature	Spec. Dwg. No.	Remarks	
Basic	Connectors	A06B-6059-K103	Soldered type	
		A06B-6059-K104	Crimped type	
	Fuse	A06B-6059-K012	For Model 6S - Model 12S, 3S/12000 - 12S/8000, 8VH	
		A06B-6059-K022	For Model 15S - Model 22S, 15S/8000 - 22S/6000, 12VH	
Option	Speed gain switching circuit	A06B-6059-J700		
Option	Power transformer	A06B-6044-J006	For Models 6S, 8S, 3S/12000, 8S/8000	Primary 380V line 415V 460V
		A06B-6044-J007	For Models 12S, 15S, 12S/8000, 15S/8000, 8VH, 12VH	Secondary line 200V
		A06B-6044-J010	For Models 18S, 22S, 18S/6000, 22S/6000	
	Unit adaptor	A06B-6059-K031	For Models 6S - 12S, 3S/12000 - 12S/8000, 8VH	
		A06B-6059-K032	For Models 15S - 22S, 15S/8000 - 22S/6000, 12VH	

(*1) For optional orientation, refer to the items related to spindle orientation in Part V.

4. SPECIFICATIONS AND FUNCTIONS

4.1 Specifications

(1) AC spindle servo unit S series

Item \ Model	1S	1.5S	2S	3S	6S	8S	12S	15S	18S	22S
30-min. rated power source capacity	4	7	7	9	12	17	22	26	32	37
Power source (*1)	AC200V/220V/230V +10%, -15% 50/60Hz 1Hz									
Main circuit system	Transistor PWM inverter									
Feed back system	Velocity feed back by pulse generator									
Braking system (Regenerative energy processing system)	Regenerative braking (Resistance discharge)					Regenerative braking (Power regeneration)				
Input command voltage	DC + 10V (Max. speed) - 0V (Stop)									
Speed control range (Speed ratio) rpm	80 - 8000 (1:100)		45 - 6000 (1:133)		45 - 4500 (1:100) 45 - 6000 (1:133)			45 - 4500 (1:100)		
Speed variation	Less than 0.1% of the maximum speed (Load variation 10 - 100%)									
Ambient temperature (*3)	0 - 55°C									

(*1) If the power voltage is other than specified herein, a transformer is needed.

(*2) It is needed to cool forcibly the radiator fin section of the servo unit. When designing the servo unit housing, prepare a cooling fan and give careful consideration to the forced air cooling structure of the radiator fin section referring to Chapter 7 "COOLING" in this manual.

(*3) In Model 12S and Model 22S, the continuous operating time of the motor at 30-min. rated output is determined as follows by the thermal limitation of the unit.

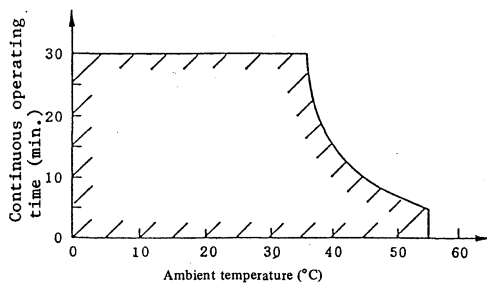

Thermally limited continuous operating time of Model 12S

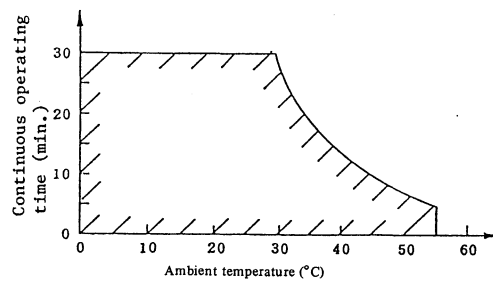

Thermally limited continuous operating time of Model 22S

(2) AC spindle servo unit S series (high-speed model)

Item \ Model	1S/ 15000	2S/ 15000	3S/ 12000	6S/ 12000	8S/ 8000	12S/ 8000	15S/ 8000	18S/ 6000	22S/ 6000
30-min. rated power source capacity kVA	4	7	9	12	17	22	25	32	37
Power source (*1)	AC200/220/230V, +10%, -15%; 50/60Hz±1Hz								
Main circuit system	Transistor PWM inverter								
Feed back system	Velocity feed back by pulse generator								
Braking system	Regenerative braking (Resistance discharge)			Regenerative braking (Power regeneration)					
Input command voltage	+10V DC (at maximum speed) to 0V (while stopping)								
Velocity control range	150 - 15000	150 - 15000	120 - 12000	120 - 12000 rpm (Speed ratio 1:100)	80 - 8000 rpm (Speed ratio 1:100)		60 - 6000 rpm (Speed ratio 1:100)		
Speed variation	Less than 0.1% of the maximum speed in the load variation range from 10 to 100%								
Ambient temperature (*3)	0 - 55°C								

- (*1) A transformer is needed when the power voltage is other than specified herein.
- (*2) It is needed to cool forcibly the radiator fin section of the servo unit. When designing the servo unit housing, prepare a cooling fan and give careful consideration to the forced air cooling structure of the radiator fin section referring to Chapter 7 "COOLING" in this manual.
- (*3) In models 12S/8000 and 22S/6000, the continuous operating time of the motor at 30-min. rated output is determined as follows by the thermal limitation of the unit.

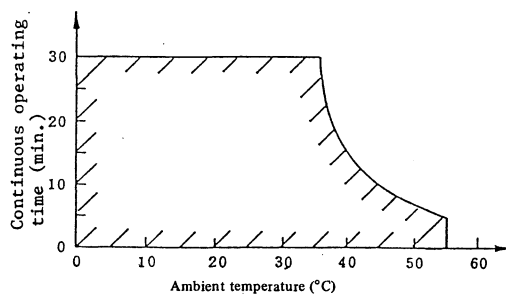

Thermally limited continuous operating time of Model 12S/8000

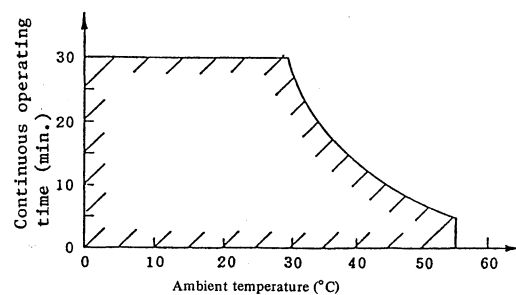

Thermally limited continuous operating time of Model 22S/6000

4.2 Major Component Functions and Application

4.2.1 Spindle control unit

The spindle control unit rectifies three-phase AC input, and converts it into DC so as to perform the velocity control of the AC spindle motor through transistor PWM inverter.

The spindle control unit is provided with a protective and fault detection function as shown in (1) for the purpose of protecting machine, AC spindle motor, and AC spindle servo unit, if trouble has occurred. It also provides an auxiliary function as shown in (2) for monitoring the operating conditions of the spindle.

(1) Protective and fault detection functions

(1)-1 Spindle Control Unit for Models 1S - 3S

Item	Description	Display
Motor overheat detection	An alarm occurs when the internal temperature of AC spindle motor and power circuit heat radiator temperature abnormally increase.	AL-01
Excessive velocity deviation detection	An alarm occurs when the AC spindle motor speed is largely deviated from the commanded speed due to an overload, etc.	AL-02
Detection of discharge circuit abnormality	An alarm is generated when current flows in the regenerative resistor unit for longer than a certain time.	AL-03
Overspeed detection	If the AC spindle motor speed exceeds 110 to 115% of the rated maximum speed, an alarm occurs.	AL-06 AL-07
Overvoltage detection	If the AC input power circuit voltage exceeds the rated voltage range, an alarm occurs.	AL-08
Undervoltage detection	If the control power voltage abnormally drops, an alarm occurs.	AL-10
Main circuit overvoltage detection	If the main circuit voltage abnormally rises, an alarm is emitted.	AL-11
Main circuit over-current detection	If an abnormally large current runs through the main circuit, an alarm occurs.	AL-12
Abnormal arithmetic circuit detection	An alarm occurs when any abnormality of the arithmetic circuit or its peripheral parts is detected.	AL-16 - 23
Abnormal ROM detection	An alarm occurs when ROM is found abnormal.	

(1)-2 Models 6S - 22S

Item	Description	Display
Motor overheat detection	Alarm is emitted when the temperature inside the AC spindle motor rises abnormally.	AL-01
Excessive velocity deviation detection	Alarm is emitted when the AC spindle motor speed tremendously deviates from the command speed due to reasons such as overload.	AL-02
Detection of melted control power circuit fuse	The melting of +24V fuse in the control power section is detected.	AL-03
Detection of lost input power phase	Alarm is emitted when any of the input power phases are lost.	AL-04
Overspeed detection	Alarm is emitted when the AC spindle motor speed exceeds 110 to 115% of the rated maximum speed.	AL-06 AL-07
Overvoltage detection	Alarm is emitted when the AC input power voltage exceeds the rated voltage range.	AL-08
Detection of main circuit overheating	Alarm is emitted when the temperature of power circuit heat radiator rises abnormally.	AL-09
Undervoltage detection	Alarm is emitted when the control power voltage drops abnormally.	AL-10
Main circuit over-voltage detection	Alarm is emitted when the main circuit voltage rises abnormally.	AL-11
Main circuit over-current detection	Alarm is emitted when abnormally large current runs through the main circuit.	AL-12
Abnormal arithmetic circuit detection	Alarm is emitted when any abnormality is detected in the arithmetic circuit and its peripheral circuits.	AL-13 16 - 23
Abnormal ROM detection	Alarm is emitted when any abnormality is found in ROM.	A
Abnormality of option circuits	Alarm is emitted when option circuits or connection to the option circuits become abnormal.	AL-15

(2) Auxiliary functions

The AC spindle control unit provides the following auxiliary functions.

Auxiliary functions	Description
Loadmeter output	The 10-VDC meter (one-sided deflection type) is connectable.
Speedometer output	The 10-VDC meter (one-sided deflection type) is connectable.
Zero-speed signal output	Spindle motor stop can be confirmed.
Speed reach signal output	This signal indicates that the spindle motor has reached the commanded speed.
Override	Overriding the command speed (auto) is possible. (Model 6S - 22S)
Speed detection signal output	The speed can be detected to confirm if it is below a certain speed such as the clutch change speed and gear change speed.
Torque limit	This serves to reduce the output torque of the spindle motor for rotation temporarily at small torque.
Display of motor rpm	Actual motor rpm is displayed in five digits, seven segments.
Selection of output limit pattern	Various kinds of output limit patterns can be selected with setting of parameter. . No output limit is made. . Output limit is made only at acceleration/ deceleration. . Output limit is made at stable rotation. . Output limit is effected for all operation ranges. Divide the maximum output by 100 for setting.
Selection of rigid tapping mode	Response characteristics for rigid tapping can be selected by the setting of parameter and input of contact signal.
Load detection signal output	When the load value exceeds the value set by parameter, the contact signal is output. Divide the maximum output by 100 for setting.

4.2.2 Resistor unit (Models 1S - 3S)

On AC spindle servo unit models 1S to 3S, the regenerative energy which accompanies motor deceleration is expended by resistors. The following items should be noted when using the resistor unit.

- (1) When choosing the motor and resistor unit, choose a resistor unit with a capacity which suits the load and run cycle time. Overheating will occur if an inappropriate resistor unit is used. Refer to item 4.2.3 for selection. The following items can also cause overheating, so caution is advised.
 - . Overheating is likely to occur, if the balance difference between the different phases of the input power source is 12% or greater, and especially if the voltage between the U-V phases is lower than that between the V-W or W-U phases. If this is the case, reconnect so that the U-V phase voltage will be the highest, as a temporary measure.
 - . If one end (unit terminal T2-2 side) of the resistor is grounded.
 - . If the unit is damaged and a fault exists in the control circuit, power transistor, etc.
- (2) When designing the mounting for the resistor unit, make sure the resistors that comprise this unit are cooled properly. Also provide adequate air ventilation.
- (3) When there is an abnormality, such as overloading, the thermostat on the resistor is activated. However, the unit is allowed to be heated up to the operating temperature (about 130°C). (The specified temperature for activation of the thermostat is 120 +6°C.) If there are any vinyl coated wires nearby, there is a possibility that they will melt. There is a strong chance that the covering for the power line of the power source (AC 200V) might melt, in particular, and a short circuit accident can occur. When wiring, make sure that the cables don't touch the resistor unit case, with these precautions in mind.
- (4) Connect so that the thermostat, upon activation, will send an emergency stop signal (ESP) to the spindle amp via the power sequence circuit. (See figure below.)

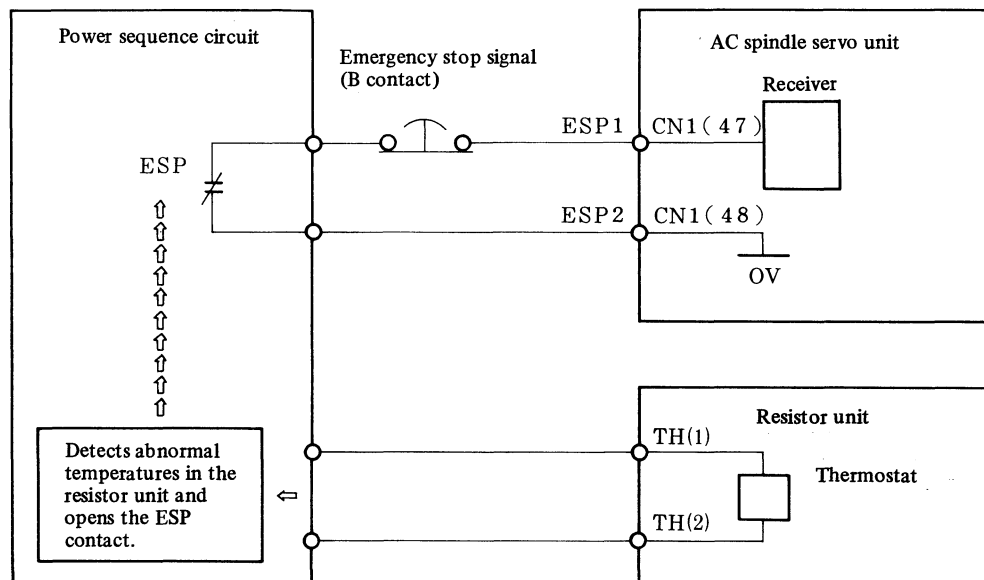

The figure above applies when there is one resistor unit.

4.2.3 Resistor unit selection standard

For models 1S, 1.5S, 2S and 3S, energy during motor deceleration (regenerative operation) is consumed in the resistor unit. Heating of this resistor unit changes, depending on the motor type, operating speed rpm, load inertia and continuously repeated cycle (duty cycle). The resistor unit includes two types: one type uses one resistor of 1 kW 15 Ω, and another type uses two resistors of 1 kW 30 Ω in parallel. Selection method between these two types is described below.

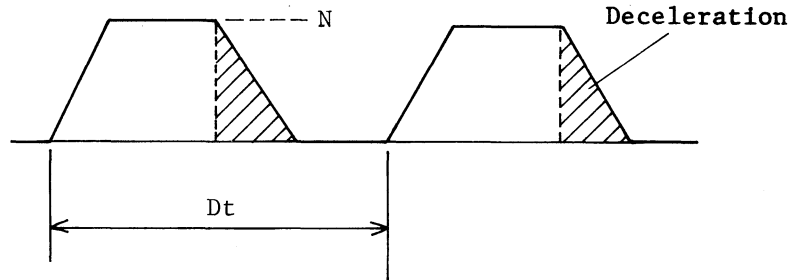

In the continuously repeated operation illustrated above, assuming the operating speed rpm to be N (rpm), motor rotor inertia to be J_m (kg.m.s²) and spindle motor shaft converted load inertia to be J_L (kg.m.s²), the allowable duty cycle times D_{t1} , D_{t2} are found as follows:

When one resistor 15 Ω is used:

$$D_{t1} = 179.2 \times (J_m + J_L) \times N^2 \times 10^{-6} \text{ (sec)} \dots\dots\dots (1)$$

When two resistors 30 Ω are used in parallel:

$$D_{t2} = 89.6 \times (J_m + J_L) \times N^2 \times 10^{-6} \text{ (sec)} \dots\dots\dots (2)$$

When four resistors 15 Ω are used in serial:

$$D_{t3} = 44.8 \times (J_m + J_L) \times N^2 \times 10^{-6} \text{ (sec)} \dots\dots\dots (3)$$

The results of the calculation in the case of the resistor unit (1) regarding each motor model are shown in the figures 1 - 4 in the following page.

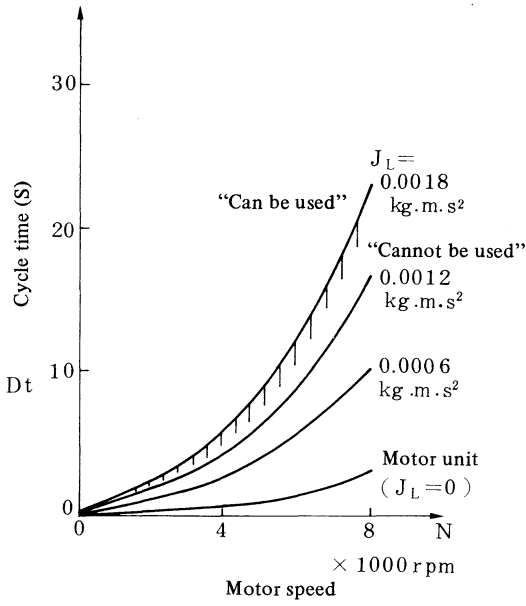

Fig. 1 Model 1S

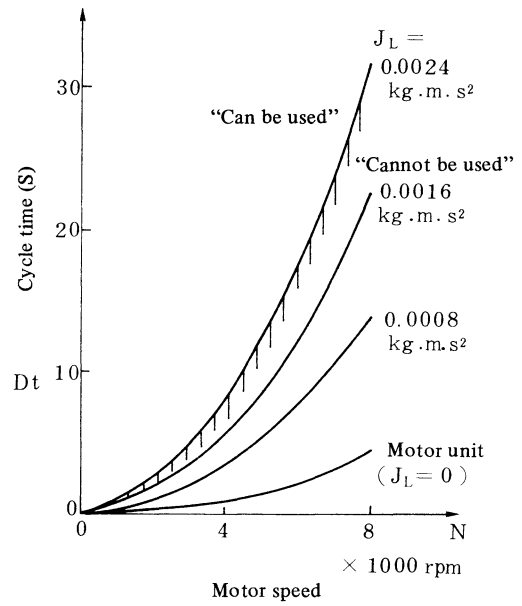

Fig. 2 Model 1.5S

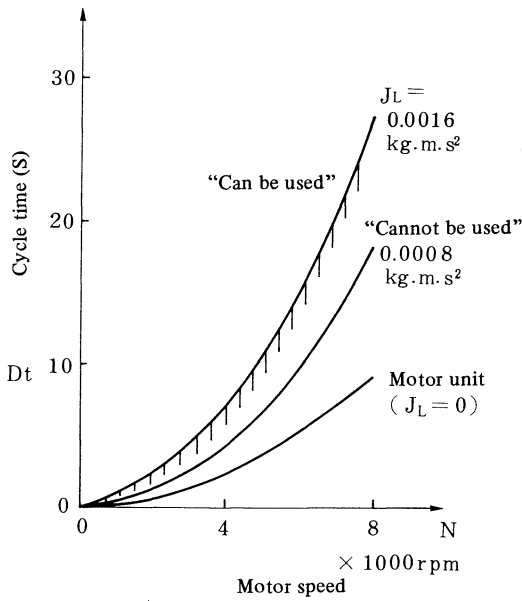

Fig. 3 Model 2S

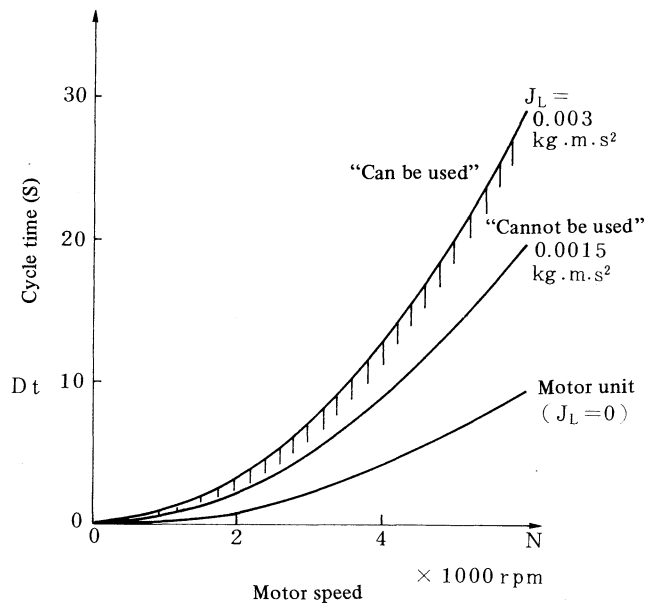

Fig. 4 Model 3S

Note) Explanation of the figures:

- 1) Operation duty cycle time in the upper side of the curve corresponding to motor axis conversion load inertia can be used, but cannot be used in the lower side due to overheating of the resistor.
- 2) In the case of resistor unit (2), the cycle time of figures 1 - 4 is 1/2.
- 3) In the case of resistor unit (3), the cycle time of figures 1 - 4 is 1/4.

[Example]

The following table shows motor axis conversion load inertia of the spindle, which is permissible when repetition is conducted at the maximum operating speed when the permissible duty cycle is 30 secs.

No.	Model name	Motor rotor inertia	Maximum operating speed	Permissible motor axis conversion load inertia	
				Resistor (15 Ω, 1)	Resistor (30 Ω, 2 in parallel)
1	1S	0.0003	8000	0.00231	0.00493
2	1.5S	0.0004	8000	0.00221	0.00483
3	2S	0.0008	8000	0.00181	0.00443
4	3S	0.0015	6000	0.00315	0.00780

Duty cycle limitation with 2 discharge resistors

Cooling structure

As shown in the diagram below, configure the equipment with a duct structure so that the surface of the resistor is subjected to intense cooling. The fan motor and mounting fittings are to be provided by the user.

One resistor used (example)

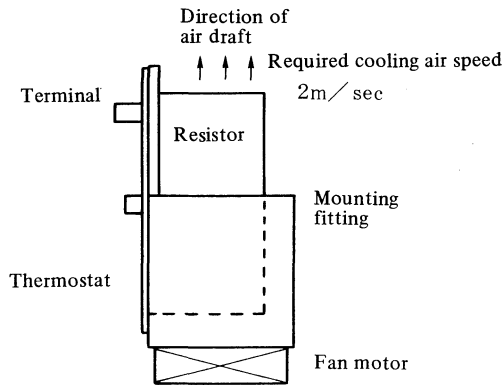

Two resistors used (example)

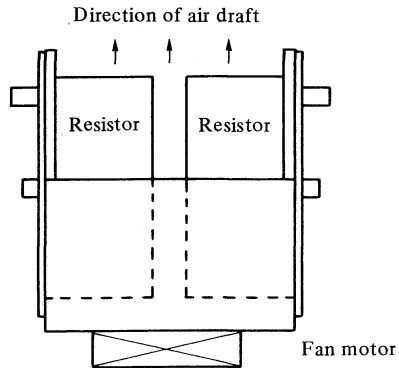

Note) It is not necessary to cool the surface retaining the thermostat.

4.2.4 Types of connectors

Connectors for the connector cable side are built into the control print board of the AC spindle servo unit, and they are therefore, specified together. In addition, the speed feedback signal cable connector is provided with the motor. The following types of connectors are included for each model of AC spindle servo unit.

(1) For Models 1S - 3S

Applica- tion	Connector specifications; FANUC specification drawing number (manufacturer's model)	Order drawing number		Remarks
		A06B-6059-K101 (Type with solder)	A06B-6059-K102 (Crimp type)	
CN1	A63L-0001-0134/01 (MR-50LFH)	1		Connector with cover (50 pins, female)
	A63L-0001-0134/21 (MRP-50LF01)		1	
CN2	A63L-0001-0134/02 (MR-20LFH)	1		Connector with cover (20 pins, female)
	A63L-0001-0134/22 (MRP-20LF01)		1	

(2) For Models 6S - 22S

Applica- tion	Connector specifications; FANUC specification drawing number (manufacturer's model)	Order drawing number		Remarks
		A06B-6059-K103 (Type with solder)	A06B-6059-K104 (Crimp type)	
CN1	A63L-0001-0134/01 (MR-50LFH)	1		Connector with cover (50 pins, female)
	A63L-0001-0134/21 (MRP-50LF01)		1	
CN2	A63L-0001-0134/02 (MR-20LFH)	1		Connector with cover (20 pins, female)
	A63L-0001-0134/22 (MRP-20LF01)		1	
CN3	A63L-0001-0134/12 (MR-20LMH)	1		Connector with cover (20 pins, male)
	A63L-0001-0134/32 (MRP-20LM01)		1	

(3) Structure

MR-50FH (MRP-50F01)
 MR-20FH (MRP-20F01)
 MR-20MH (MRP-20M01)

Soldered/crimp-style terminal

MR-50L (MR-50L)
 MR-20L (MR-20L)
 MR-20L (MR-20L)

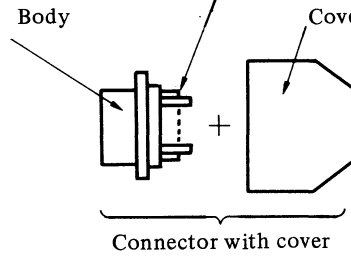

MR-50LFH (MRP-50LF01)
 MR-20LFH (MRP-20LF01)
 MR-20LMH (MRP-20LM01)

Specifications shown in parentheses are for crimp type terminal.

(4) Terminal Configuration

Use	Terminal configuration	Specifications
For CN1		MR-50FH (MRP-50F01) (50-core female)
For CN3		MR-20MH (MRP-20M01) (20-core male)
For CN2		MR-20FH (MRP-20F01) (20-core female)

Above figures are viewed from solder/crimp side. Specifications in parentheses are for crimp type.

(5) Outer diameter of compatible cable

Connector specifications	Outer diameter of cable
MR-50LFH MRP-50LF01	Max. ϕ 16 mm
MR-20LFH MRP-20LF01 MR-20LMH MRP-20LM01	Max. ϕ 10 mm

4.2.5 Fuse

Spare fuses are not attached to the AC spindle servo unit. Order more than one set of spare fuses for stock. Following fuses and parts are applied to each model of AC servo unit.

Name	Specifications FANUC Spec. Dwg. No.	Order specification		
		1S - 3S A06B-6059-K003	6S - 12S A06B-6059-K012	15S - 22S A06B-6059-K022
Fuse (5A)	A60L-0001-0031/5A	-	3	3
Alarm fuse (3.2A)	A60L-0001-0046/3.2	-	1	1
Alarm fuse (1.0A)	A60L-0001-0046/1.0	-	1	1
Fuse (3.2A)	A60L-0001-0175/3.2A	1	-	-
Fuse (1.0A)	A60L-0001-0175/1.0A	2	2	2
Fuse (0.3A)	A60L-0001-0175/0.3A	3	3	3
Surge absorber	A50L-2001-0155/ 20D431	-	1	1

4.2.6 Spindle orientation control circuit (option)

Refer to chapter "Spindle orientation".

4.2.7 Speed gain switching circuit (option for Models 6S - 22S)

Refer to chapter "Speed Gain Switching Circuit".

4.2.8 Power transformer (option)

When the input power voltage is out of range of 200 through 230 VAC, the power transformer is required.

Provide the transformer with the following specifications by the customer.

(1) Specifications

Item		Model									
		1S	1.5S	2S	3S	6S	8S	12S	15S	18S	22S
Rated capacity (kVA)	30-minute	4	7	7	9	12	17	22	26	32	37
	Continuous	3	3	4	7	9	12	17	22	26	31
Secondary current (30-minute) (A)		12	21	21	26	35	48	62	72	88	105
Secondary tap output voltage		200 V									
Secondary voltage regulation		5%									
Secondary tap voltage deviation		±3%									

(2) FANUC power transformer specifications (Option)

The following five power transformers are available. Select the servo unit according to the 30-minute rated power capacity.

Item	1S	1.5S	2S	3S	6S	8S	12S	15S	18S	22S
Order specification	A06B-6052-J001				A06B-6044-J006		A06B-6044-J007		A06B-6044-J010	
Specification	A80L-0001-0496				A80L-0001-0313		A80L-0001-0314		A80L-0001-0352	
Rated capacity	30-minute				20 kVA		30 kVA		45 kVA	
	Continuous				15 kVA		26 kVA		40 kVA	
Rated primary voltage	380/415/460 VAC +10% -15%, 230 V +10% -15%, 50/60 Hz \pm 1 Hz 3 ϕ (Secondary side is used for auto transformer)									
Rated primary current (continuous)	11A (at 380V) 10A (at 415V) 9A (at 460V)				23A (at 380V) 21A (at 415V) 19A (at 460V)		40A (at 380V) 36A (at 415V) 33A (at 460V)		61A (at 380V) 56A (at 415V) 51A (at 460V)	
Rated secondary voltage	200 VAC									
Rated secondary current (continuous)	20 A				43 A		74 A		115 A	
Secondary voltage regulation	5%									
Secondary voltage deviation	\pm 3%									
Connection	Star-star connection									
Insulation	Class H (Max. temperature 180°C)									
Ambient temperature	0 - 45°C									
Allowable temperature rise of transformer	135°C									
Humidity	Max. 95%RH									
Type	All transformers are dry-type and self-cooling									
Dielectric voltage	2000 VAC, one minute									
Weight	Max. 61 kg				Max. 115 kg		Max. 165 kg		Max. 260 kg	
External dimensions	Fig. 8.1.12				Fig. 8.1.13		Fig. 8.1.14		Fig. 8.1.15	
Connection										

(3) Secondary output voltage

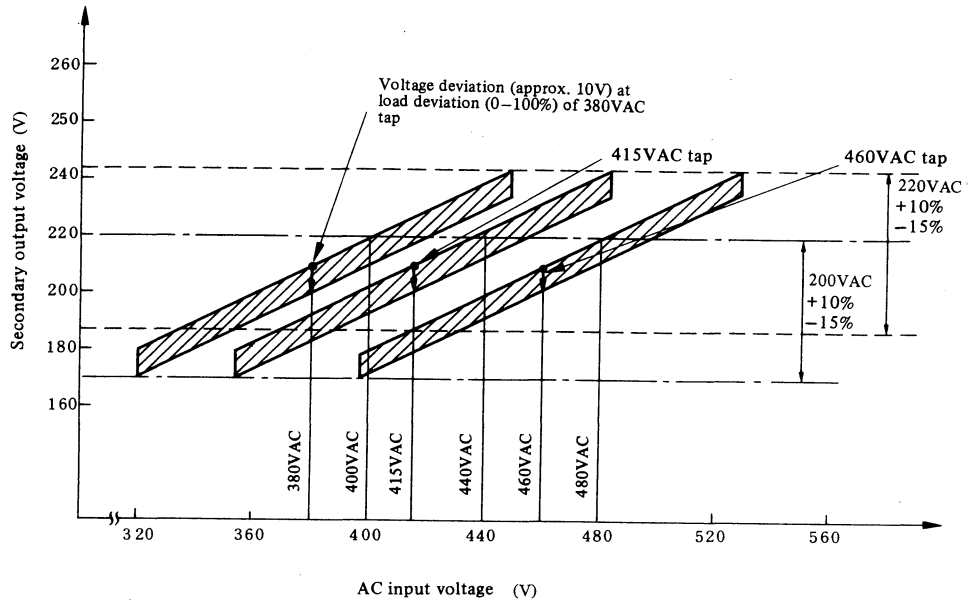

(4) Selection of Power Tap

Connect the transformer to the taps given in the following table according to AC input voltages.

Nominal input voltage	Taps used
380 VAC +10%, -15%	R1, S1, T1, G (380 V)
400 VAC +10%, -15%	R1, S1, T1, G (380 V)
415 VAC +10%, -15%	R2, S2, T2, G (415 V)
440 VAC +10%, -15%	R2, S2, T2, G (415 V)
460 VAC +10%, -15%	R3, S3, T3, G (460 V)
480 VAC +10%, -15%	R3, S3, T3, G (460 V)

(5) Cautions on use of transformer

- (a) When mounting the transformer in a cabinet, separate it so as not to give a thermal influence to an other unit.
- (b) When mounting the transformer outside, be careful not to directly expose it to cutting chips and cutting oil splash.
- (c) If the transformer may fall, mount it with bolts, etc.

4.2.9 Unit adapter (option only for models 6S - 22S)

This unit is applied to the servo unit models 6S to 22S with the inner ventilation type. When this stay is mounted the maximum depth is 319 mm for models 6S - 12S and 315 mm for models 15S - 22S. For details, refer to Chapter 8 "External Dimensions and Maintenance Area".

5. INSTALLATION

5.1 Environmental Conditions

Install the AC spindle servo unit in a place which meets the following environmental conditions.

5.1.1 Ambient temperature

Ambient temperature of the unit 0 to 55°C
Ambient temperature of the storage cabinet 0 to 45°C

5.1.2 Humidity

Normally 95% RH or below, and condensation-free

5.1.3 Vibration

In operation Below 0.5G

5.1.4 Atmosphere

No corrosive or conductive mists or drops should deposit directly on the electronic circuits.

5.2 Input Power and Grounding

(1) Input power

- * Nominal voltage rating: 200/220/230 VAC
- * Allowable voltage deviation: -15% - +10%
- * Power frequency: 50/60 Hz
- * Allowable frequency deviation: ± 1 Hz
- * Power impedance: Voltage deviation due to load (30 min. rating x 1.2) should be less than 7%.

Since the AC spindle servo unit (Model 6S - Model 22S) employs a regenerative energy system in which motor rotating energy during motor deceleration is regenerated as shop power source by means of a transistor inverter, large power impedance may cause the following restrictions or influences. So, care should be exercised when using transformers of relatively small capacity or relatively long cables.

- * Method to check power impedance

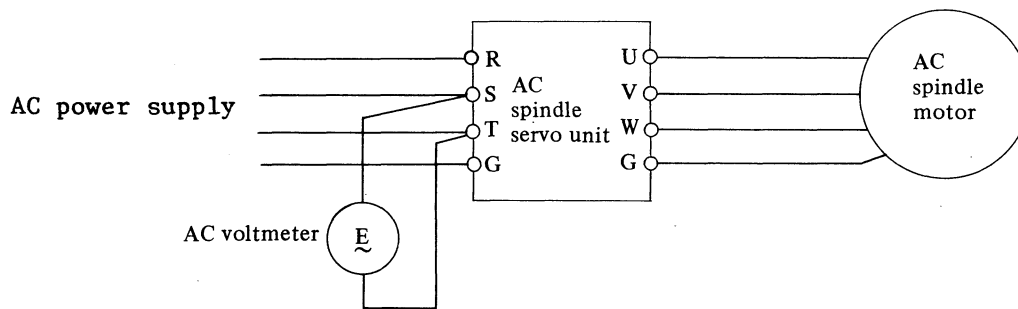

$$\frac{E_0 - E_1}{E_1} \times 100(\%) < 7(\%)$$

where,

E_0 : Voltage at motor stop

E_1 : Voltage during motor acceleration or voltage immediately before the start of speed reduction with the application of load.

- * Power supply unbalance: The range of voltage fluctuation between each phase of a 3-phase power supply is the rated voltage $\pm 5\%$ or less.
- * Install a breaker having an adequate voltage capacity for protection in the input section of the AC spindle servo unit.
- * Input power supply power factor at AC spindle motor drive is 0.9 or more. When the AC spindle motor provides most of the power for the entire machine, a low voltage phase advancing condensor must be installed.
- * Alarm No. 4 may light up in response to input power supply open phase and momentary power failure. (Models 6S - 22S).
- * Leakage current at AC spindle motor drive
As the drive circuit uses a transistor-pulse duration modulation control system, high-frequency leakage current components flow to the earth via the spindle motor and connecting cables. However, for cables of 50 m or less in length, the 50/60 Hz leakage current is equal to or less than the non-operating current (15 mA) of the general high-sensitivity, high-speed earth leakage breaker.
- * Radio noise
As the drive circuit uses a pulse duration modulation control system, high-frequency current when switching over the transistor may cause generation of noise if a radio is installed close to the AC spindle motor and the drive circuit.
The noise will have an effect on AM radio, but not on FM radio or TV. Consider the following items as measures related to mounting and machinery installation in order to minimize radio noise.
 - (a) Install the AC spindle servo unit in a metal cabinet.
 - (b) Run the connection cable which exists between the AC spindle servo unit and the AC spindle motor, through a metal duct and earth the duct.
 - (c) Make connections between the terminals of the AC spindle servo unit and the AC spindle motor (the G terminals of each unit) as specifications.

(2) Ground

Be sure to ground cables shown below.

- * Ground cable of input power supply
- * Ground cable of an AC spindle servo unit and motor

(3) Installation of an AC line filter

Whenever using the the AC spindle servo unit models 1S - 3S without a power supply transformer, be sure to install an AC line filter.

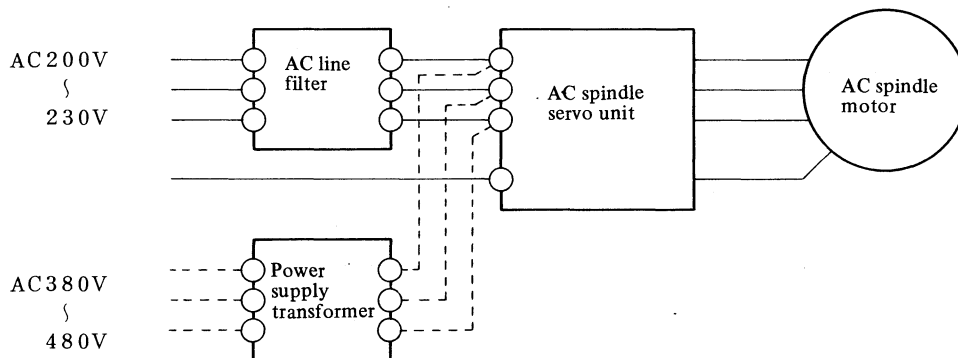

6. UNIT CALORIFIC VALUE

6.1 Calorific Value of the AC Spindle Servo Unit

Model	1S	1.5S	2S, 1S/15000, 2S/15000	3S	6S 3S/12000, 8P, 12P	8S 6S/12000, 15P	12S 8S/8000, 12S/8000, 18P, 8VH	15S, 15S/8000, 22P, 12VH	18S, 18S/6000, 30P	22S, 22S/6000, 40P
Caloric value at continuous rated output [W]	280	280	310	340	420	500	660	840	1050	1250

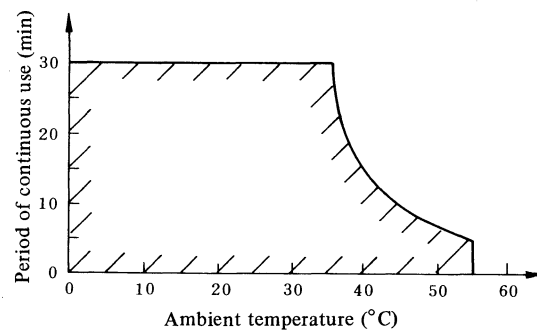

Thermally limited period of continuous use of the servo unit (Model 12S)

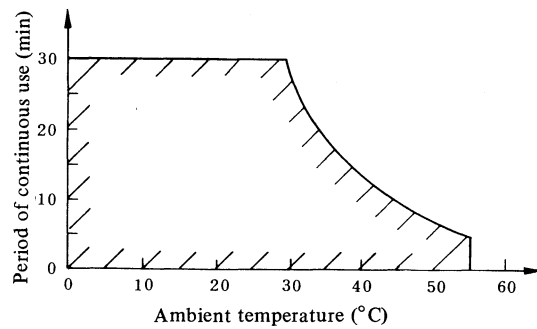

Thermally limited period of continuous use of the servo unit (Model 22S)

7. COOLING

The AC spindle servo unit S series employs the structure of external cooling for the radiator of the power circuit. It is required to consider forced-air cooling for cooling the radiator of the power circuit. The cooling fan necessary for forced-air cooling is provided by the MTB.

* The AC spindle servo unit S series does not employ the built-in fan.

* If the unit is not cooled properly, an overheat alarm or a problem may occur.

7.1 AC Spindle Servo Unit

Cool the radiator of the AC spindle servo unit using wind in accordance with the undermentioned figure and with wind shown in Table 7.1, which can radiate 70% of the carolic value.

Table 7.1 Cooling the AC spindle servo unit

Model	1S - 3S, 1S/15000, 2S/15000	6S - 12S, 3S/12000 - 12S/8000, 8P - 18P, 8VH	15S - 22S, 15S/8000 - 22S/6000, 22P - 30P, 12VH
Wind speed	More than 2 m/sec	More than 3 m/sec	More than 3.5 m/sec

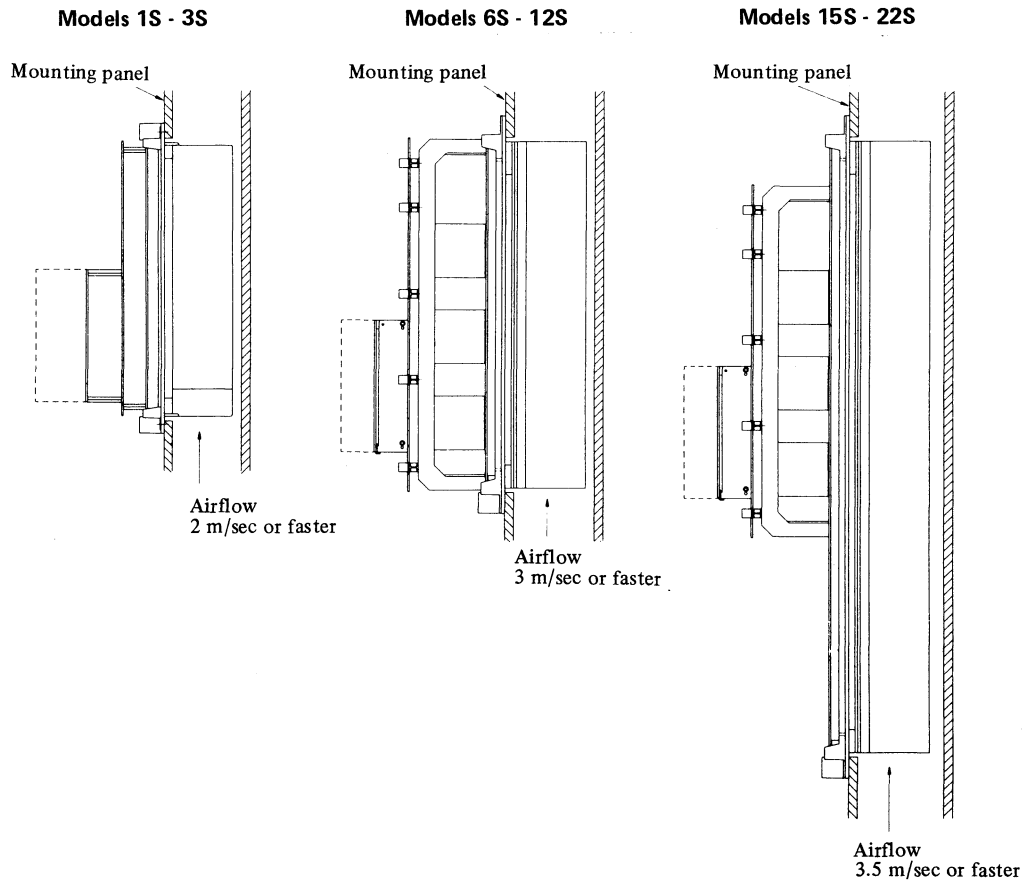

Note) Magnetics cabinet structure to be employed to prevent fan motor wind leakage whenever forced-air cooling is performed.

Remarks) The required wind speed is obtained by using a unit adaptor.

The unit adapters are provided with three-phase fan motors (model No. 5915PT-20W-B30-S04 made by N.M.B.), one for models 6S-12S each and two for models 15S-22S each.

However, those produced in June, 1990 or earlier are provided with single-phase fan motors (model No. 5915PC-20T-B30-100 made by N.M.B.).

As an example of the three-phase fan motor for cooling, the model #5915PT made by N.M.B. is shown below. For the single-phase fan motor model #5915PC, refer to Appendix 3.

[Specifications]

Model	Voltage V	Fre- quency Hz	Max. air flow m ³ / min	Max. static pres- sure mmAq	Speed rpm	Cur- rent A	Input power W	Noise dB	Weight kg
5915PT-20W-B30-S04	200 ^{+20%} -15%, 3φ	50	5.5	13	2650	0.18	26.0	53	0.8
	200 ^{+20%} -15%, 3φ	60	6.3	14.3	2900	0.22	26.0	55	

[External dimensions]

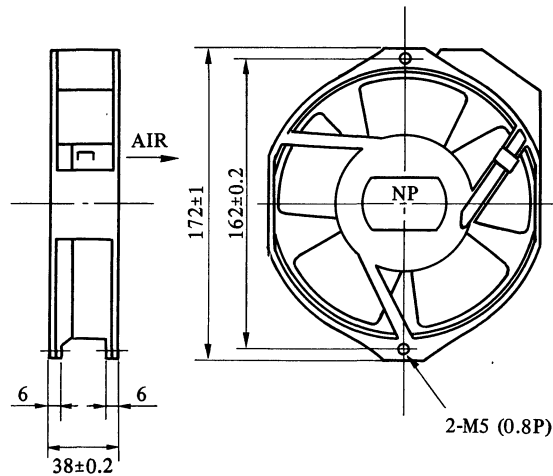

7.2 Cooling the Resistor Unit (Models 1S - 3S, Model 1S/15000, Model 2S/15000)

Cooling the resistor unit (except connecting terminal surface) using a wind in accordance with the undermentioned figure and with a wind shown in Table 7.2. For further details, refer to 4.2.2 Resistor unit (Model 1S - 3S, 1S/15000, 2S/15000).

Table 7.2 Cooling the resistor unit

Model	1S - 3S
Wind speed	More than 2 m/sec

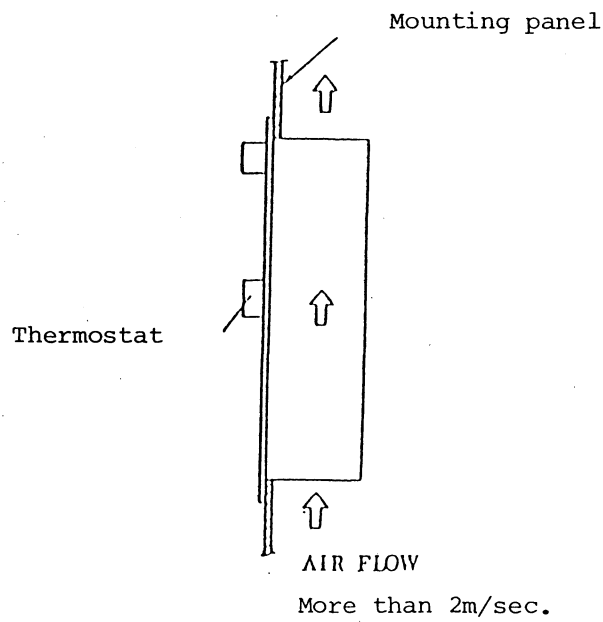

8. EXTERNAL DIMENSIONS AND MAINTENANCE AREA

8.1 External Dimensions

As for the external dimensions of the spindle orientation circuit and the speed gain switching circuit, refer to the chapters "Spindle orientation" and "Speed gain switching circuit" respectively.

8.1.1 AC spindle servo unit models 1S - 3S, model 1S/15000, model 2S/15000 (orientation using position coder)

(Refer to the item 8.1.3 for the resistor unit and 8.1.4 as far the connectors.)

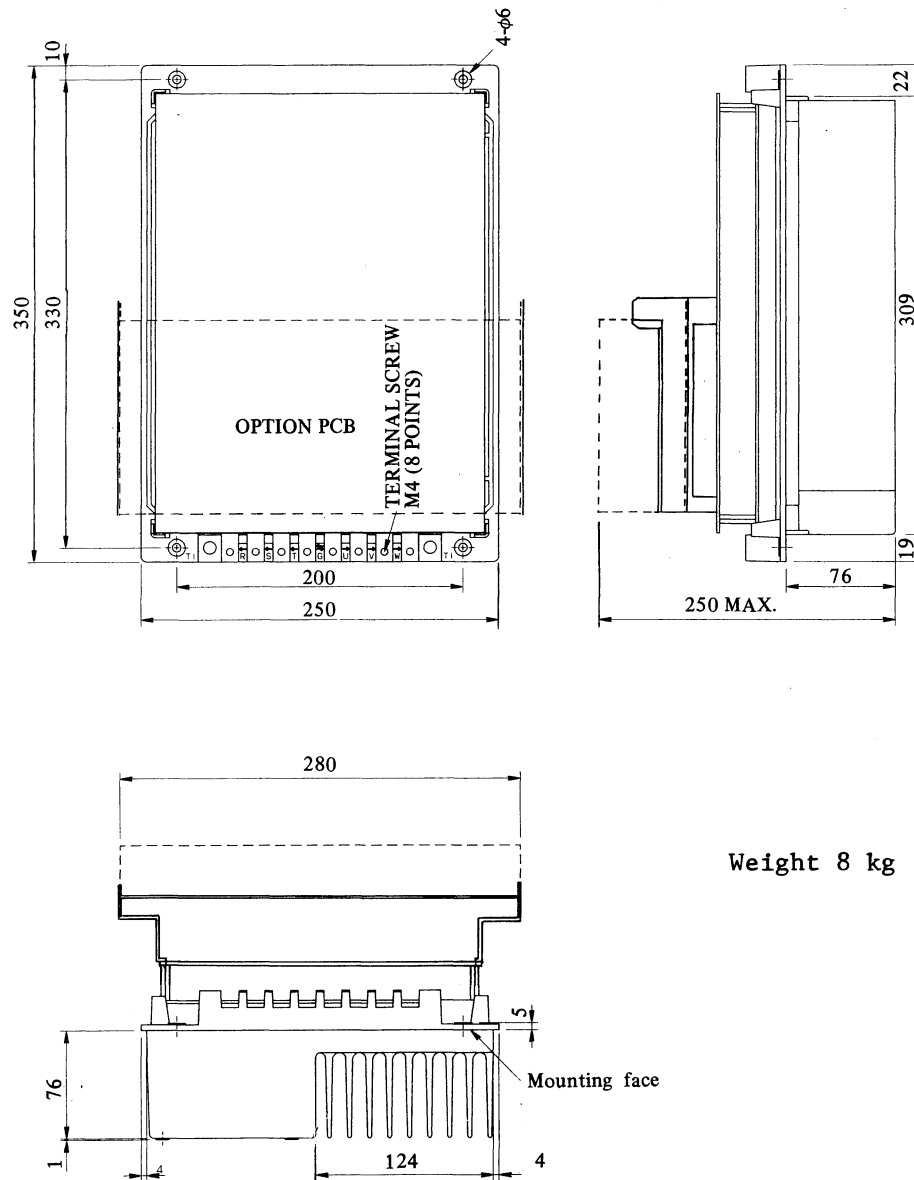

**8.1.2 AC spindle servo unit models 1S - 3S, model 1S/15000, model 2S/15000
(orientation using magnetic sensor)**

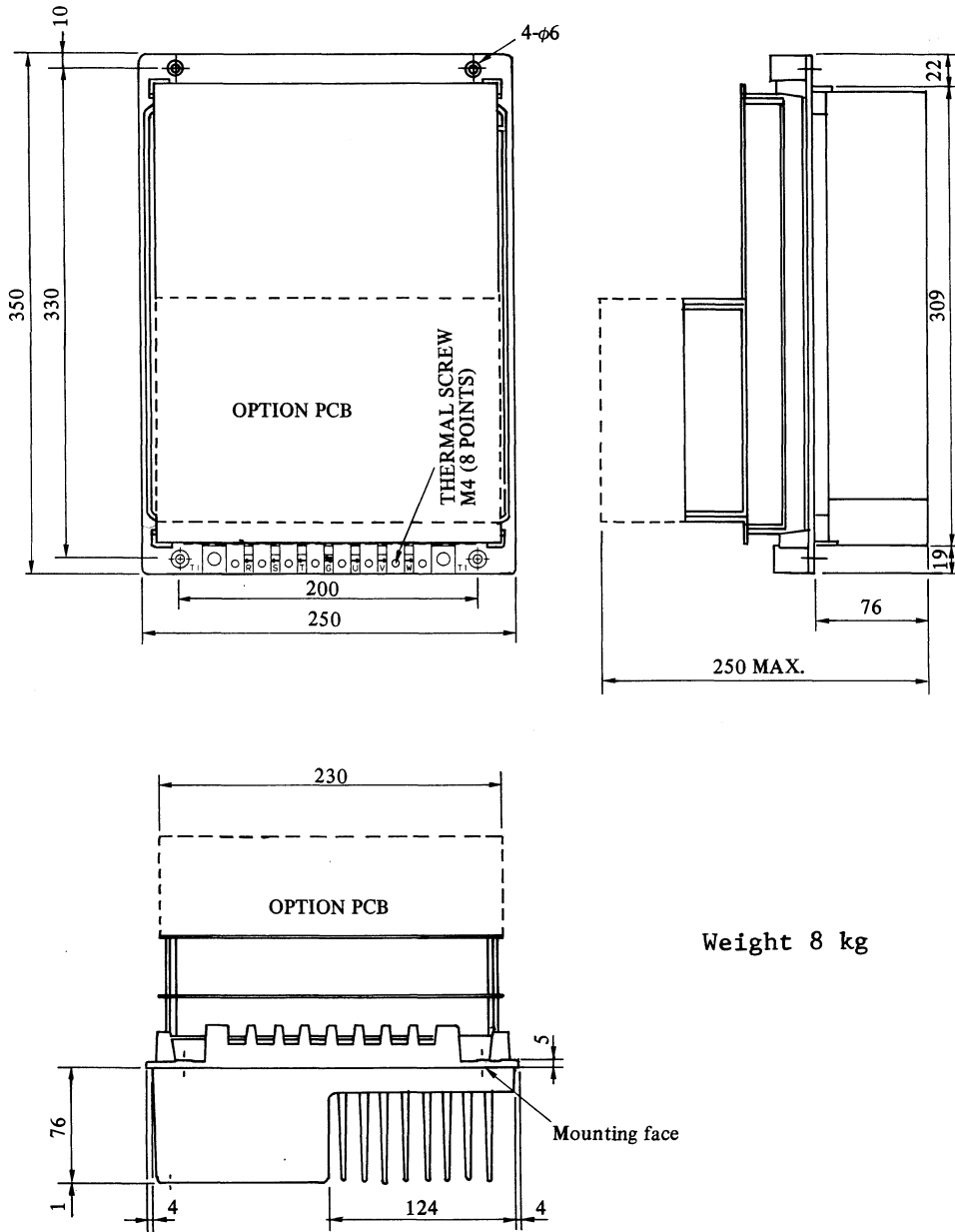

Weight 8 kg

8.1.3 Resistor unit (order specification: A06B-6052-K050)

Two resistor units of the undermentioned external dimensions are used for A06B-6052-K051.

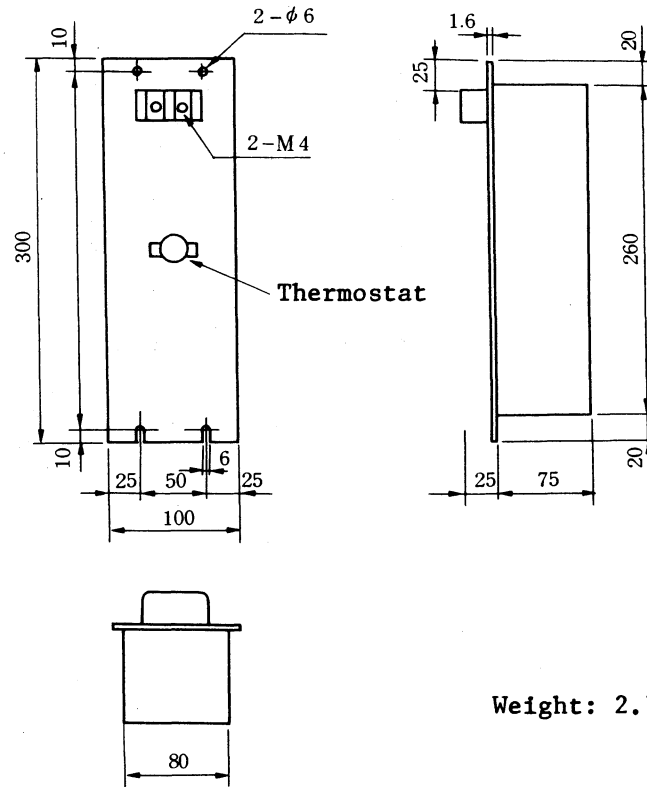

Weight: 2.7 kg

8.1.4 Connector

Symbol Specification	A	(B)	C	(D)	Number of terminals
MR-50LFH	67.9	73.5	44.8	18	50
MR-20LFH MR-20LMH	39.3	44.9	39.8	17	20

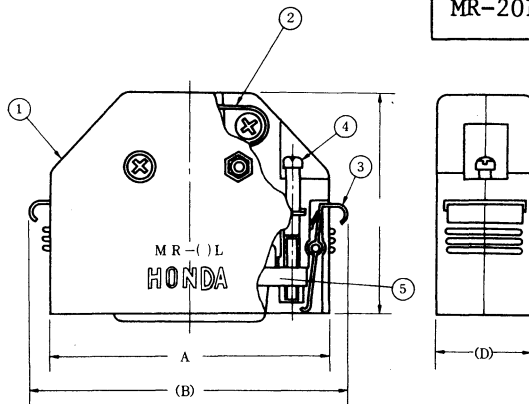

Remarks Name of components

Symbol	Name
①	Connector cover
②	Cable clamp
③	Spring for connector clamp
④	Screw for connector clamp
⑤	Male connector

8.1.5 AC line filter (order specification: A81L-0001-0083/3C)

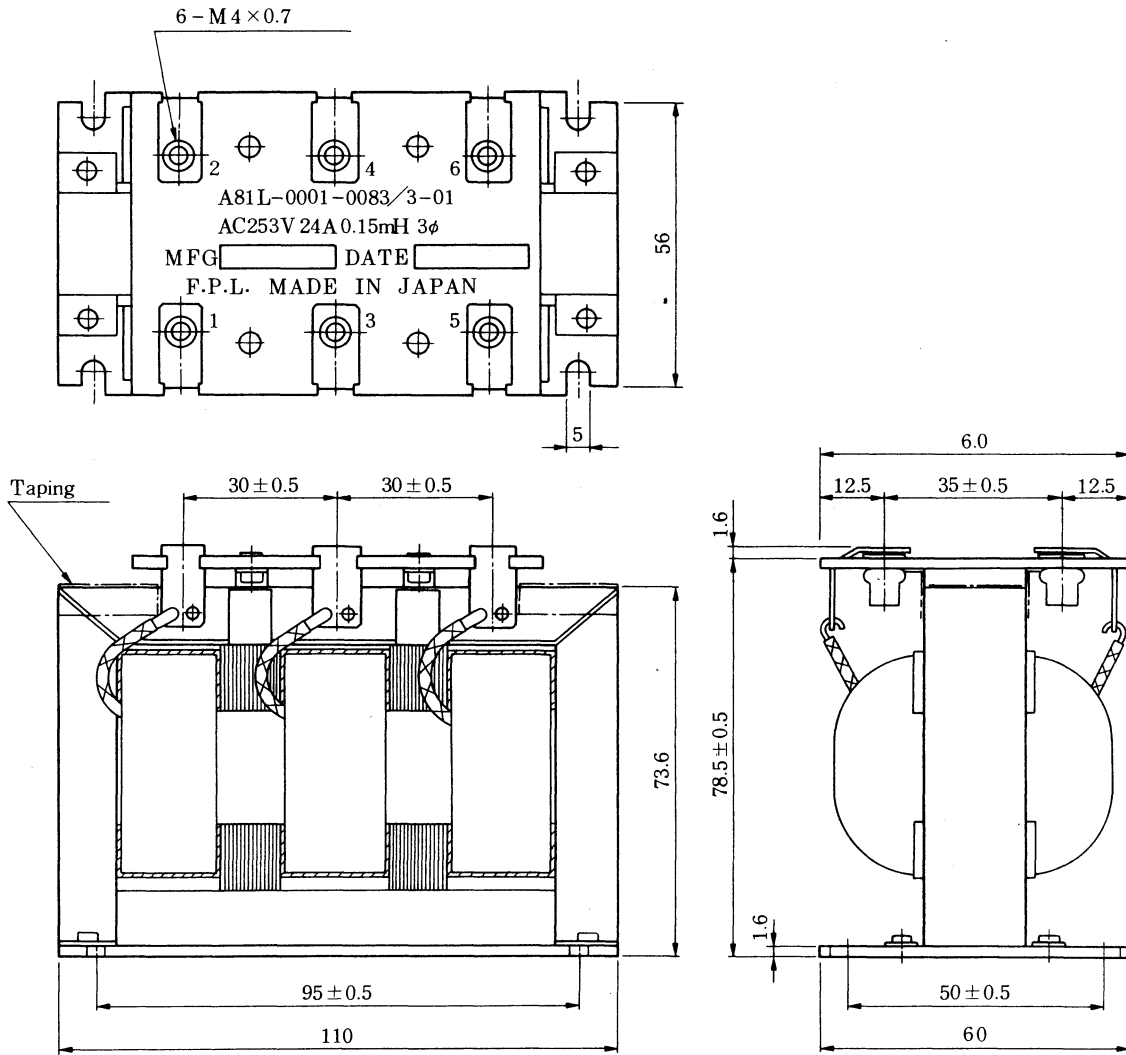

Weight: 2 kg

8.1.6 AC spindle servo unit model 6S, 8S, 12S, model 3S/12000, 6S/12000, 8S/8000, 12S/8000, model 8P, 12P, 15P, 18P, model 8VH (with unit adaptor)

(Refer to item 8.1.10 for the external dimensions for the unit adaptor and item 8.1.4 for connectors.)

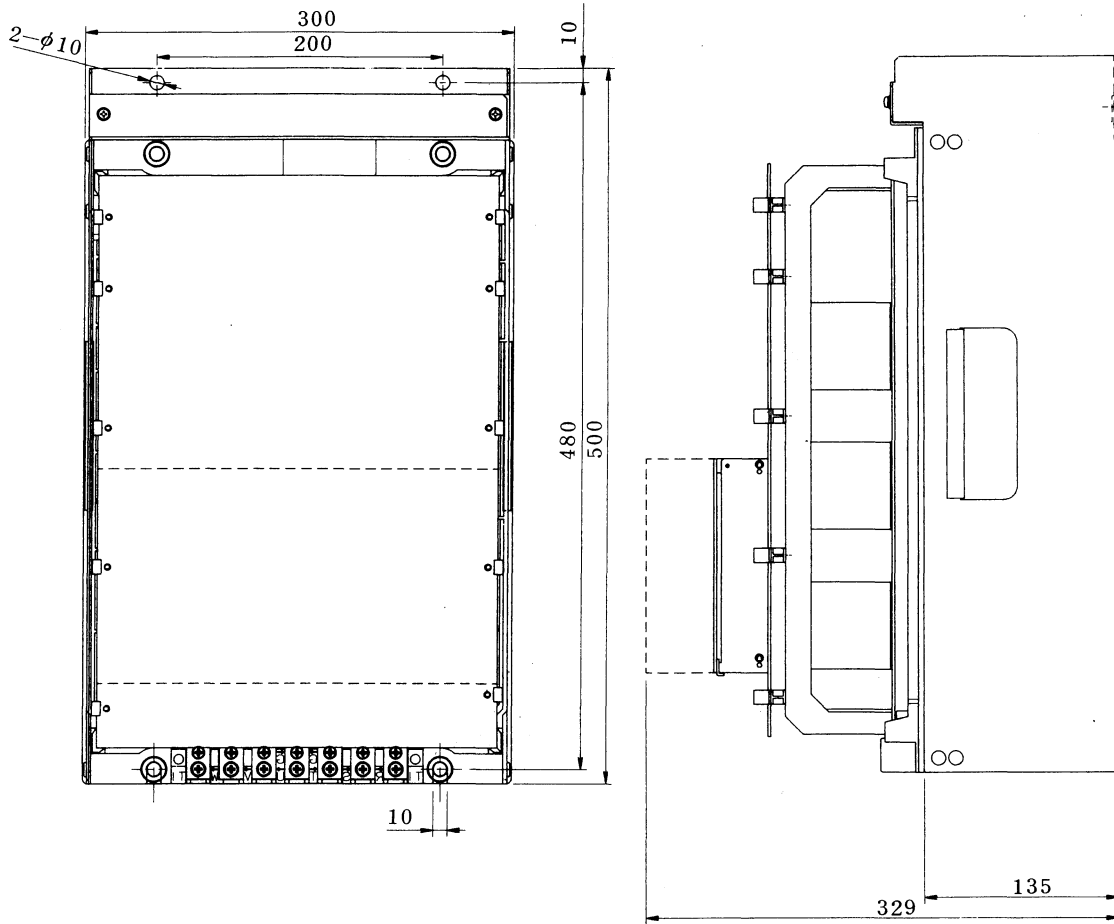

Wight: 23 kg

8.1.7 AC spindle servo unit model 6S, 8S, 12S, model 3S/12000, 6S/12000, 8S/8000, 12S/8000, model 8P, 12P, 15P, 18P, model 8VH (without unit adaptor)

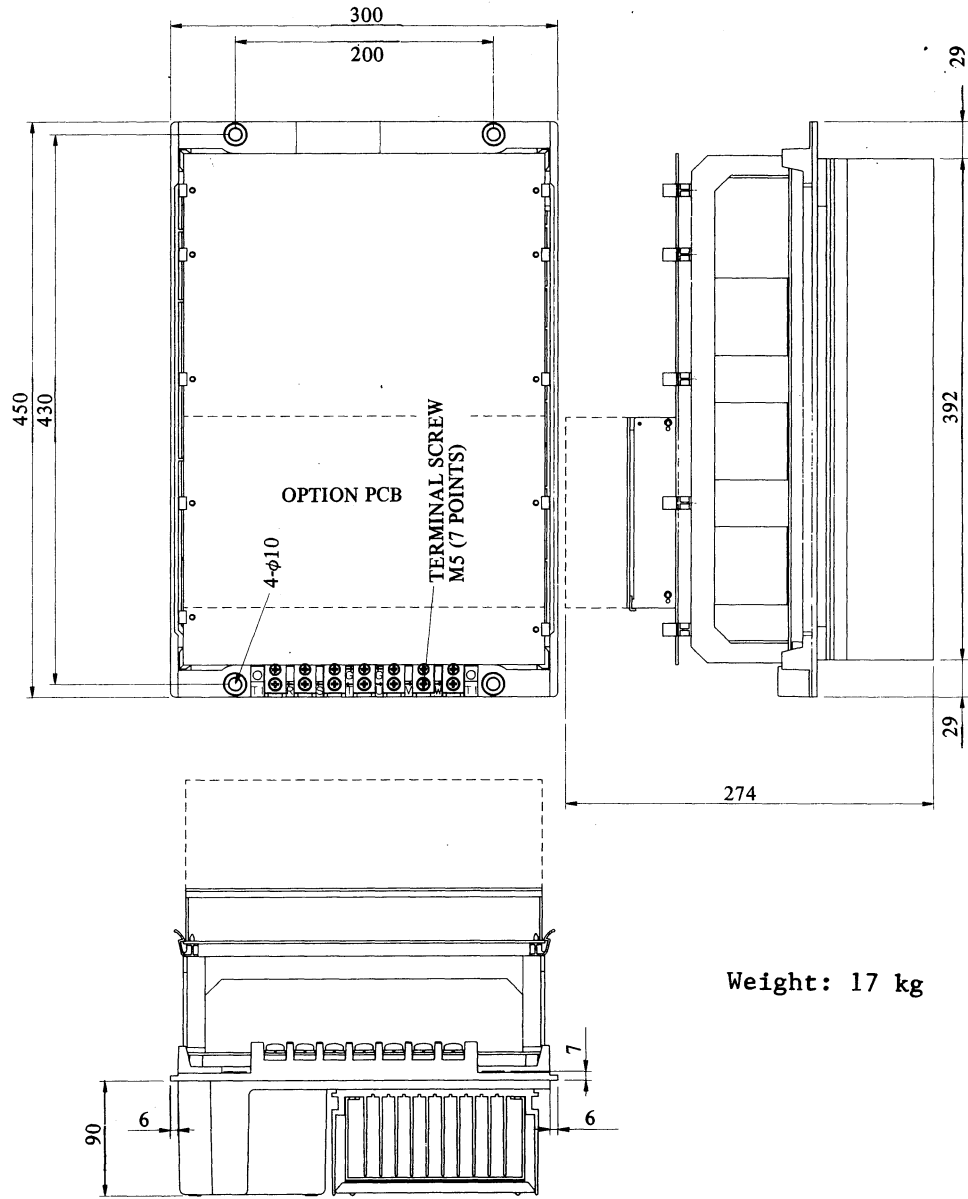

Weight: 17 kg

**8.1.8 AC spindle servo unit model 15S, 18S, 22S, model 15S/8000, 18S/6000, 22S/6000,
model 22P, 30P, 40P, model 12VH (with unit adaptor)**

(Refer to item 8.1.11 for the external dimensions for the unit adaptor and the
item 8.1.4 for the connectors.)

1) In case where a protection cover is attached (Sept. 1990 on)

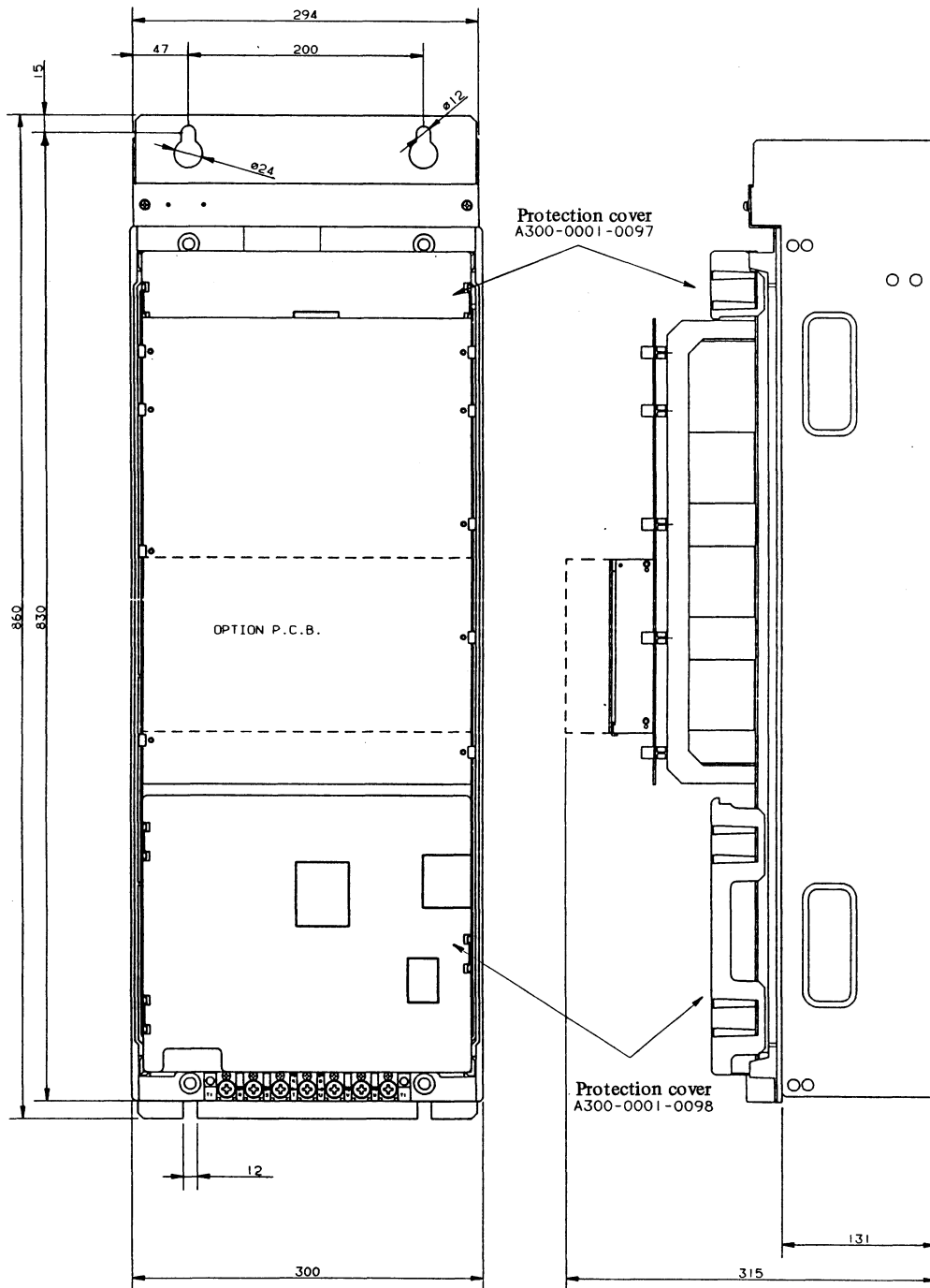

2) In case where no protection cover is attached (Aug. 1990 or earlier)

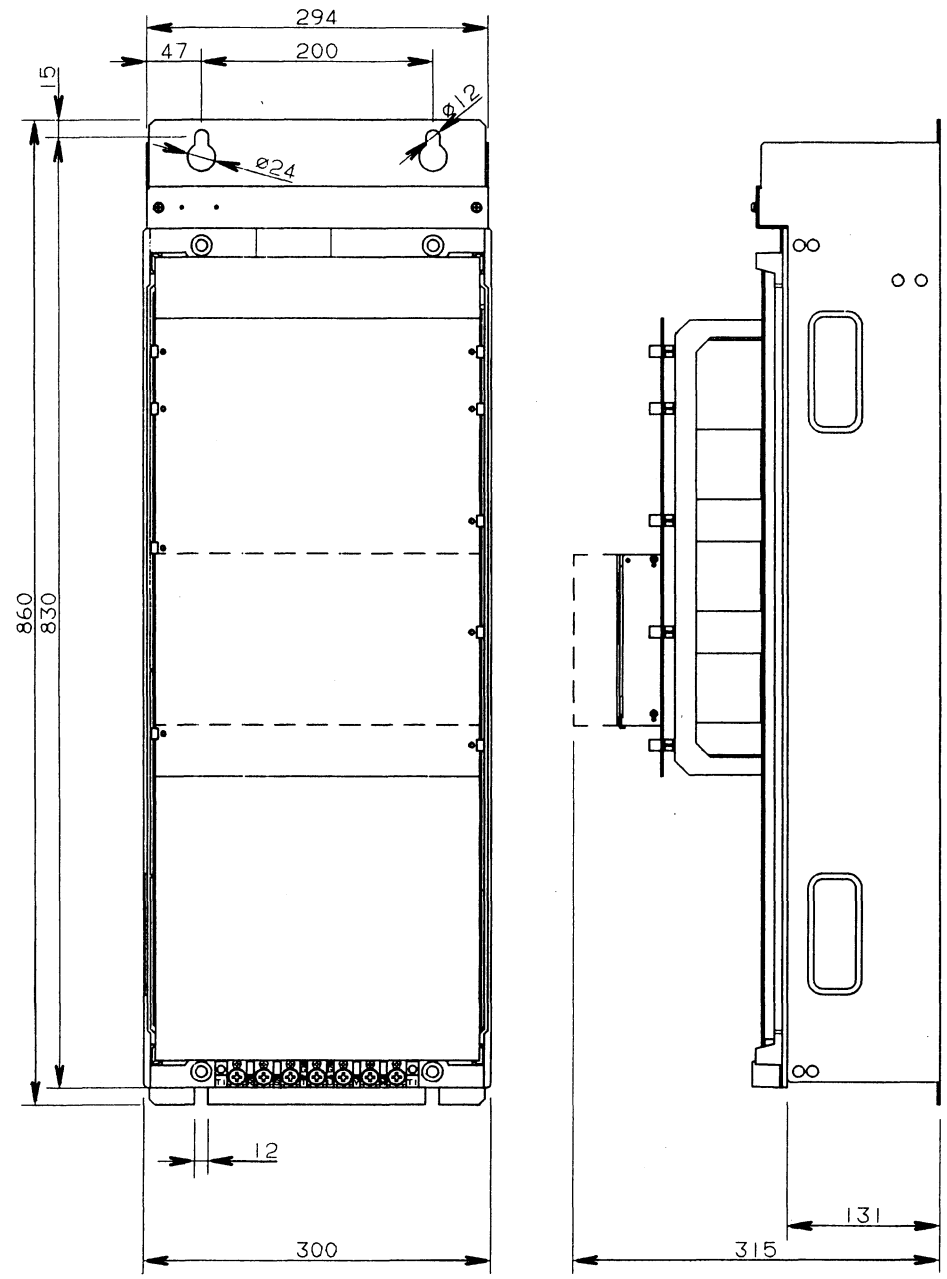

Weight: 40 kg

8.1.9 AC spindle servo unit model 15S, 18S, 22S, model 15S/8000, 18S/6000, 22S/6000, model 22P, 30P, model 12VH (without unit adaptor)

1) In case where a protection cover is attached (Sept. 1990 on)

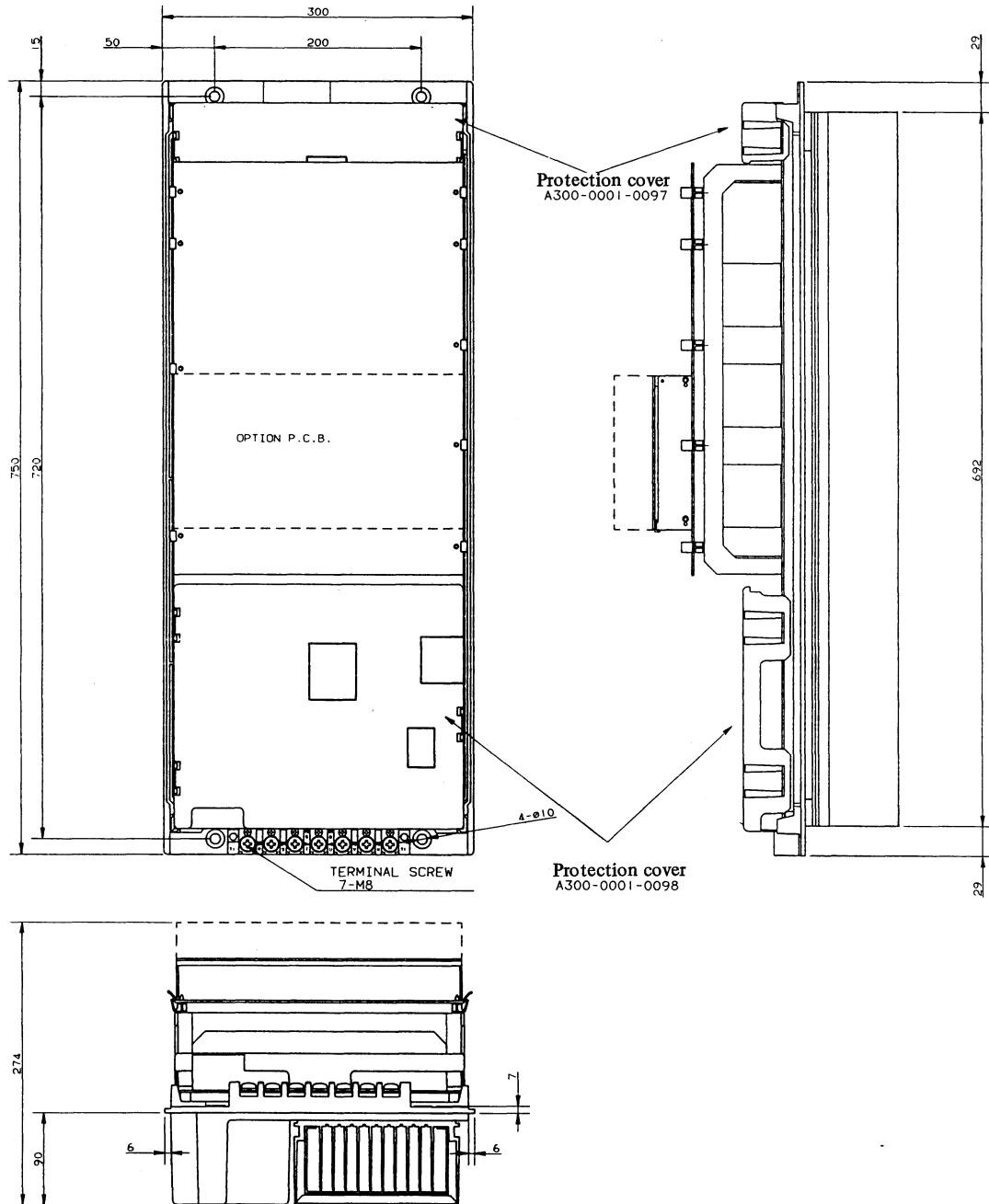

2) In case where no protection cover is attached (Aug. 1990 or earlier)

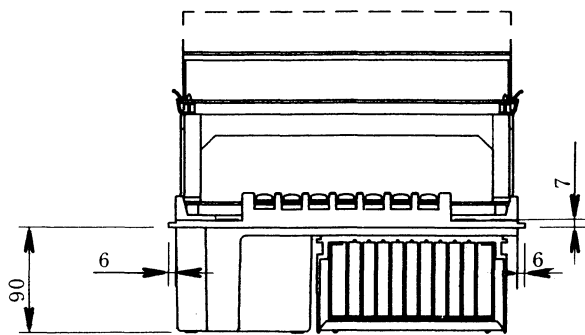
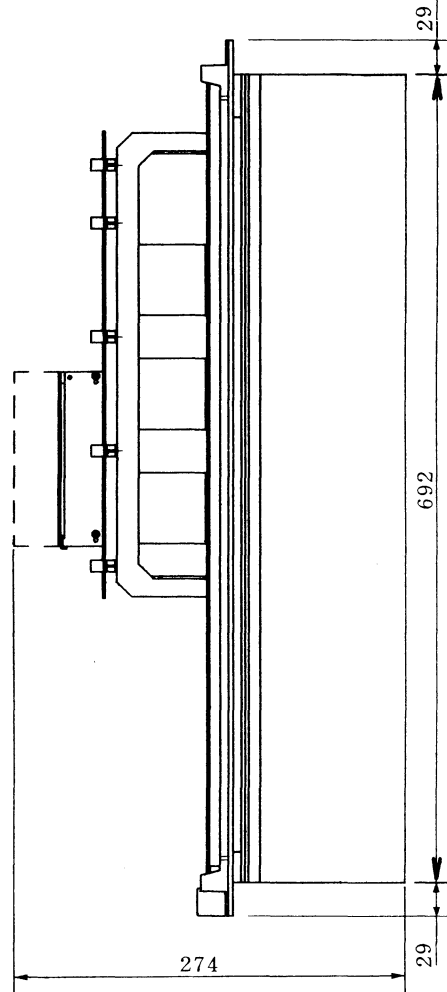
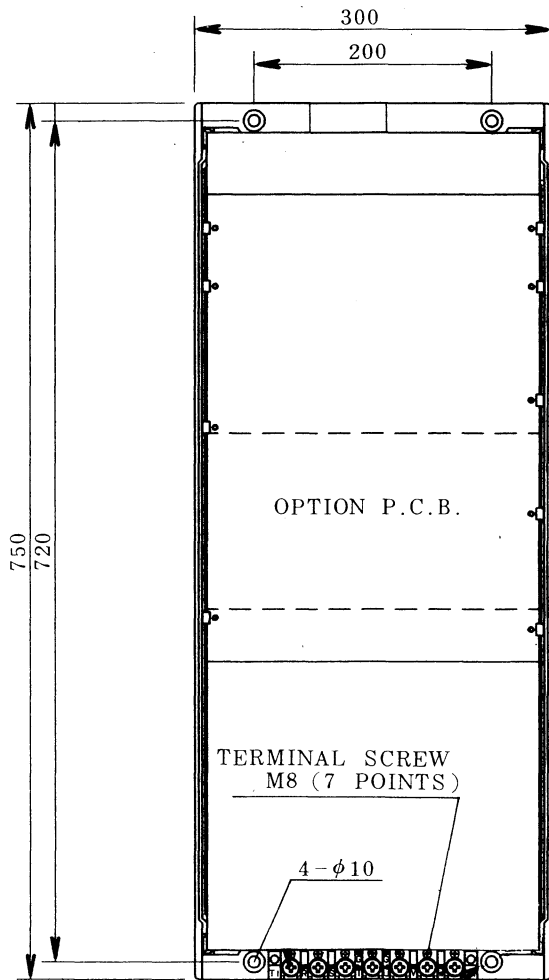

Weight: 30 kg

8.1.10 Unit adaptor (models 6S - 12S, order specification: A06B-6059-K031)

1) Three-phase fan motor included (July, 1990 on)

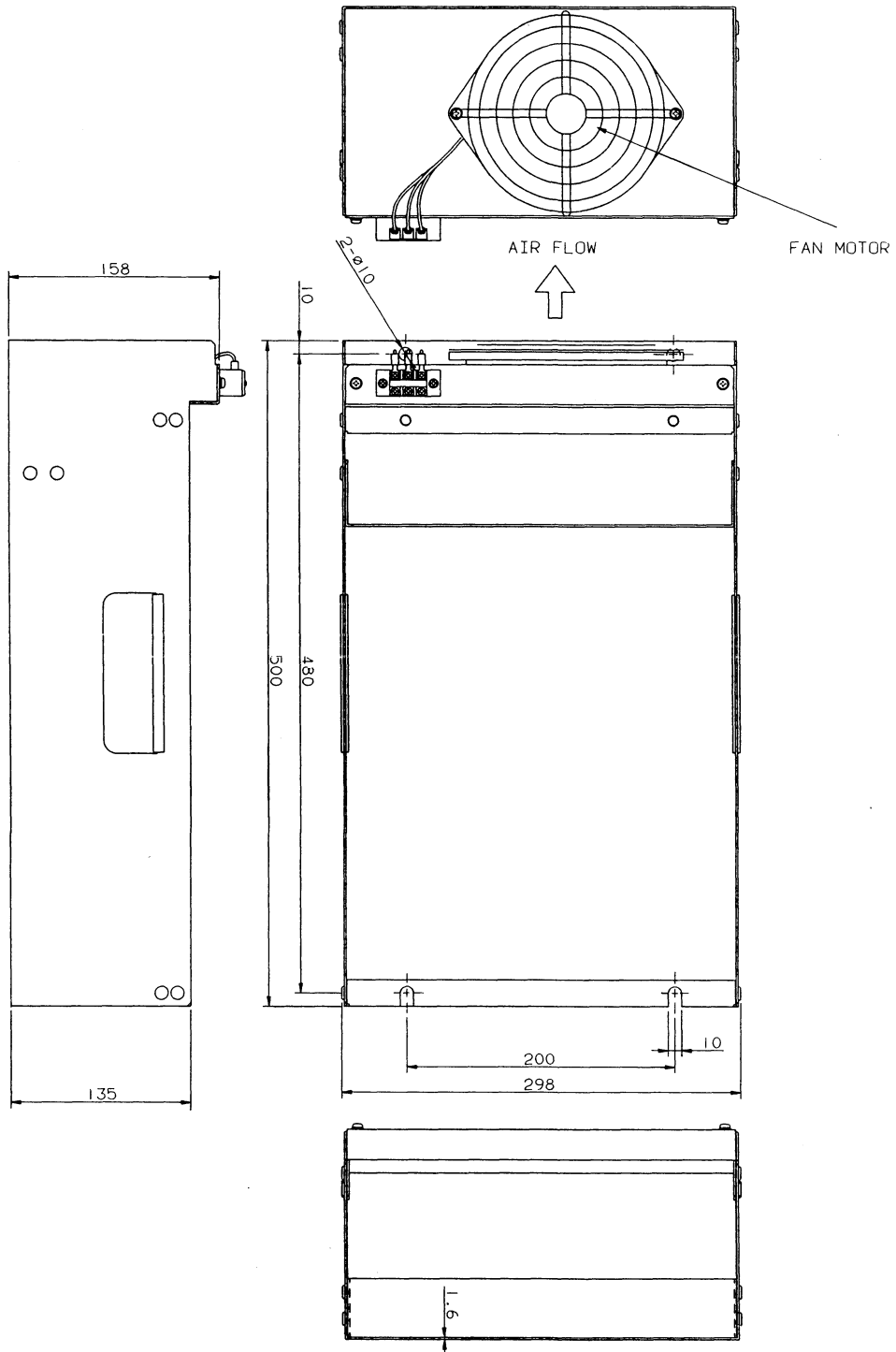

2) A single-phase fan motor included (June, 1990 or earlier)

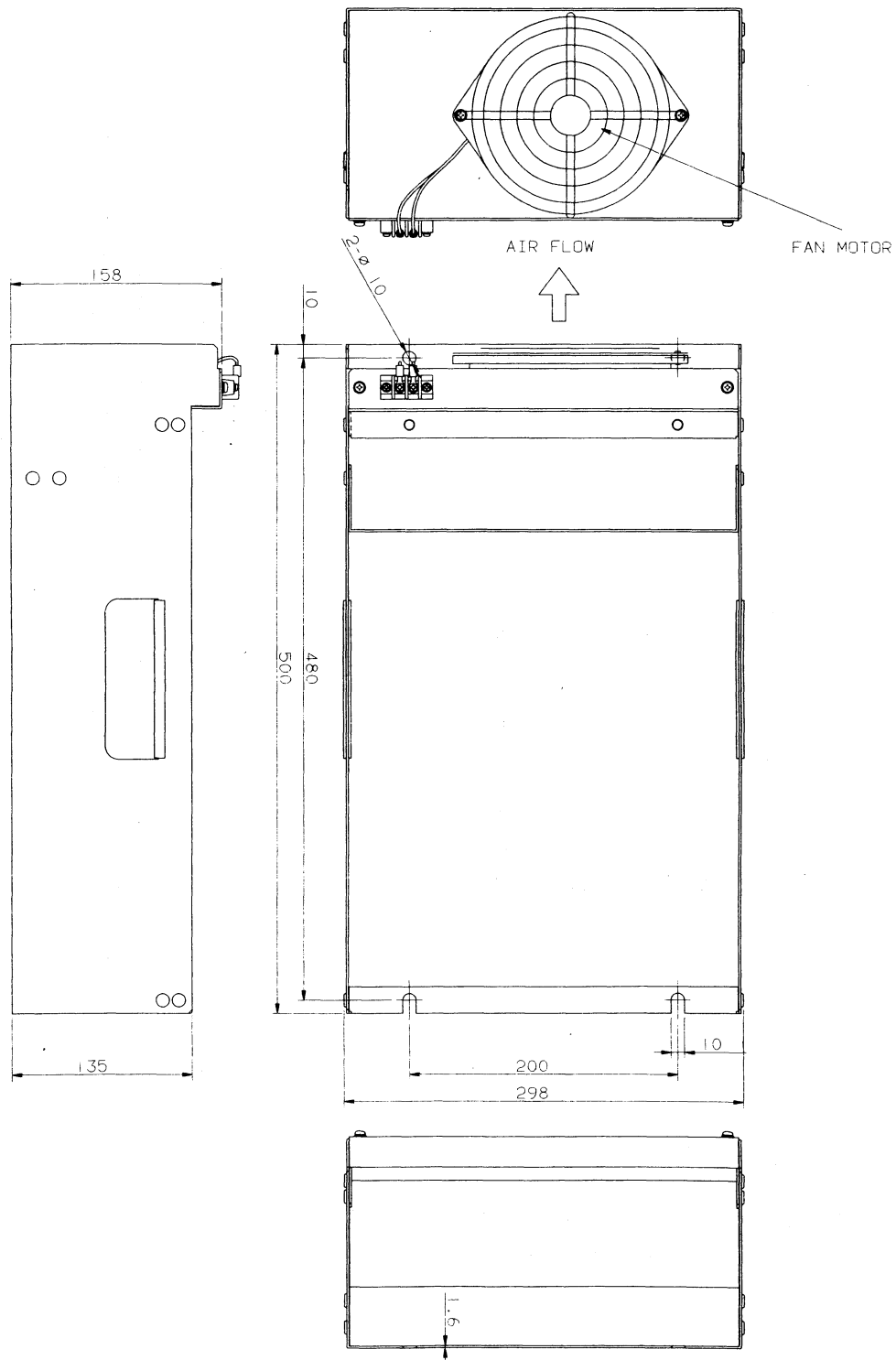

8.1.11 Unit adaptor (models 15S - 22S, order specification: A06B-6059-K032)

1) Three-phase fan motor included (July, 1990 on)

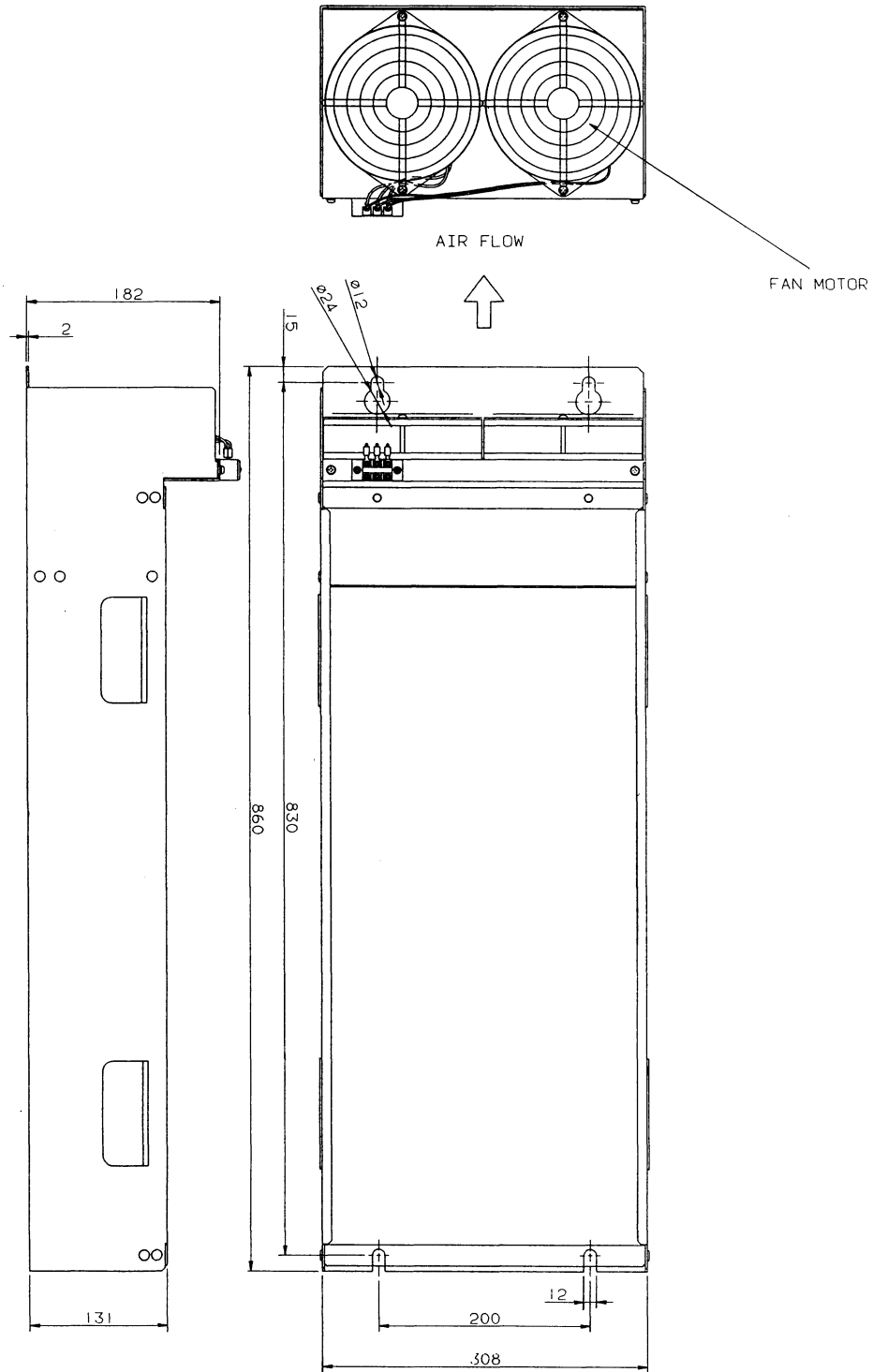

2) A single-phase fan motor included (June, 1990 or earlier)

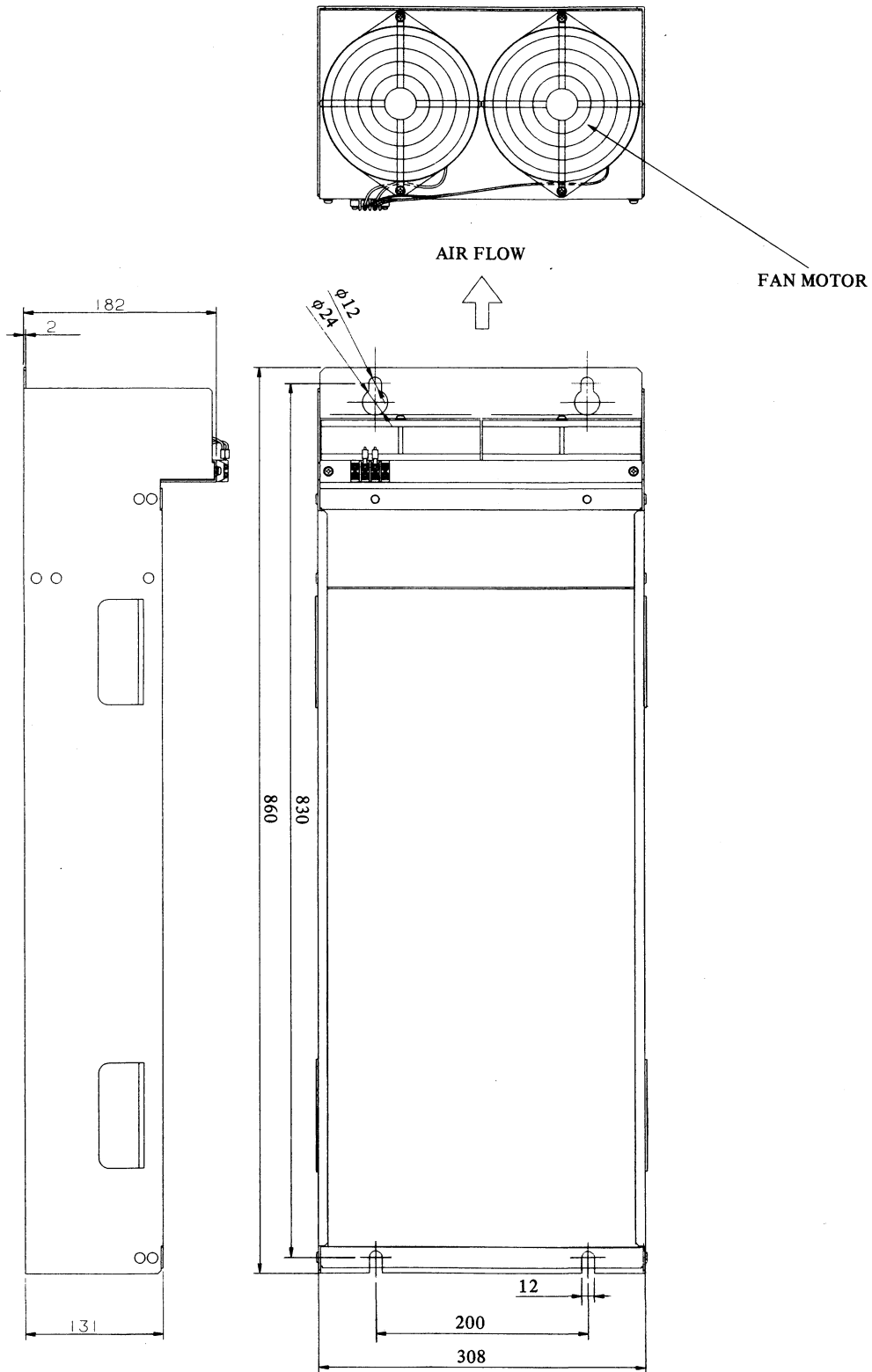

8.1.12 Power transformer, models 1S - 3S (order specification: A06B-6052-J001)

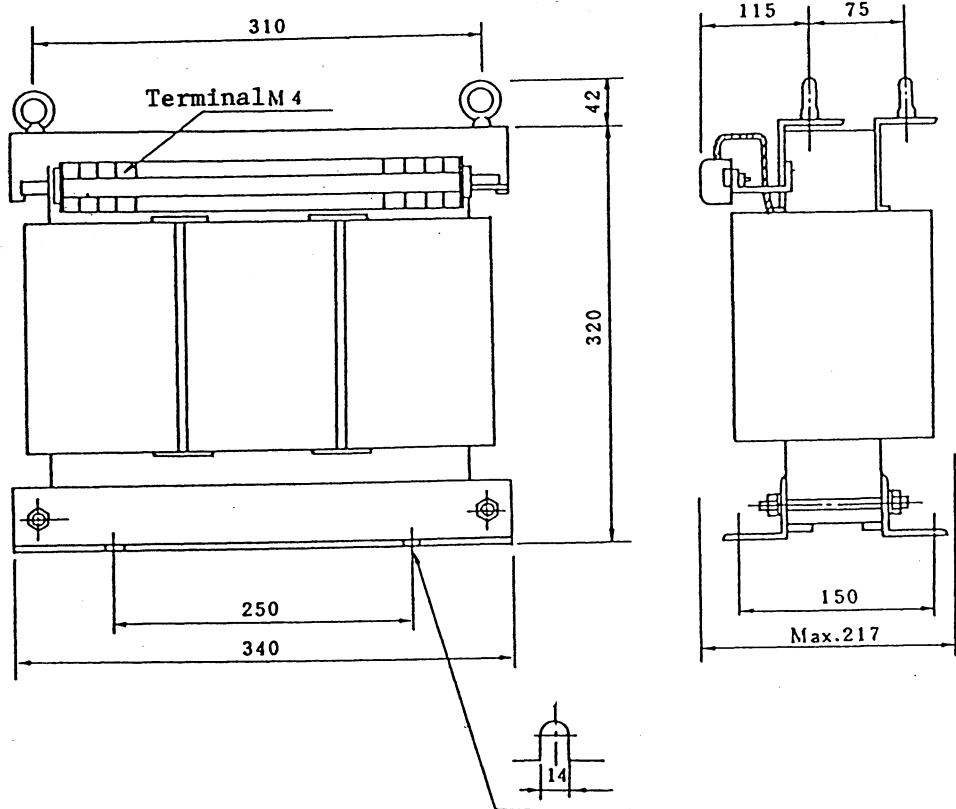

Dimensions of transformer without cover for models 1S - 3S

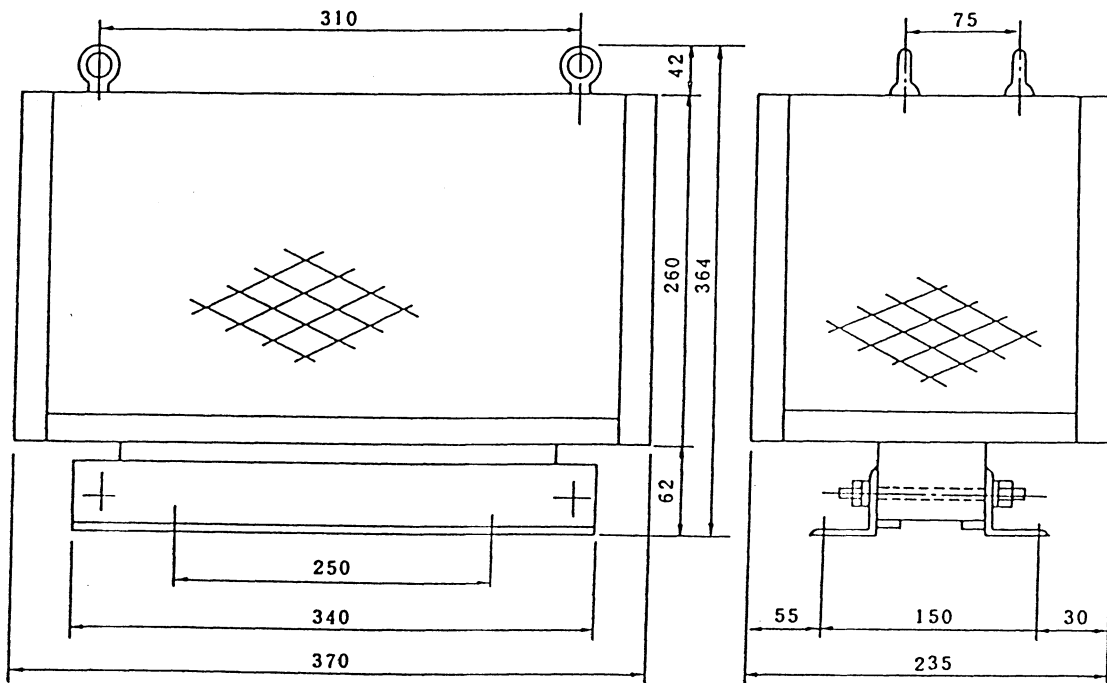

Note) Nets are covered on four sides and the plate is covered on the top.

Dimensions of transformer with cover for models 1S - 3S

8.1.13 Power transformer, models 6S, 8S (order specification: A06B-6044-J006)

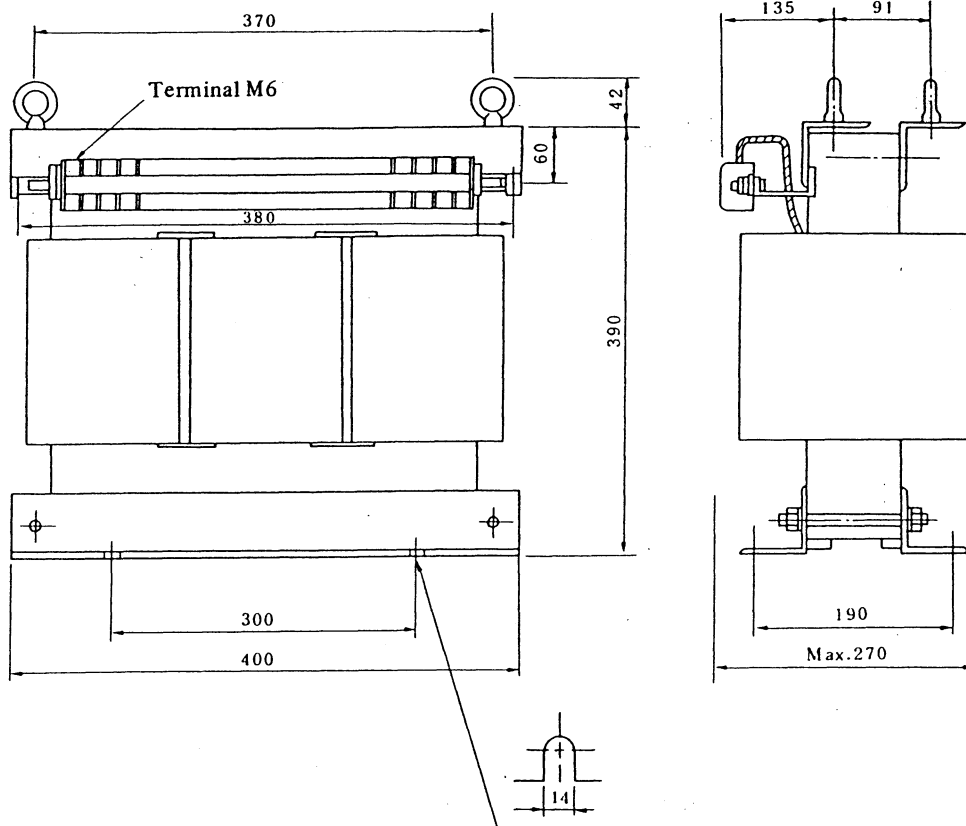

Dimensions of transformer without cover (models 6S, 8S)

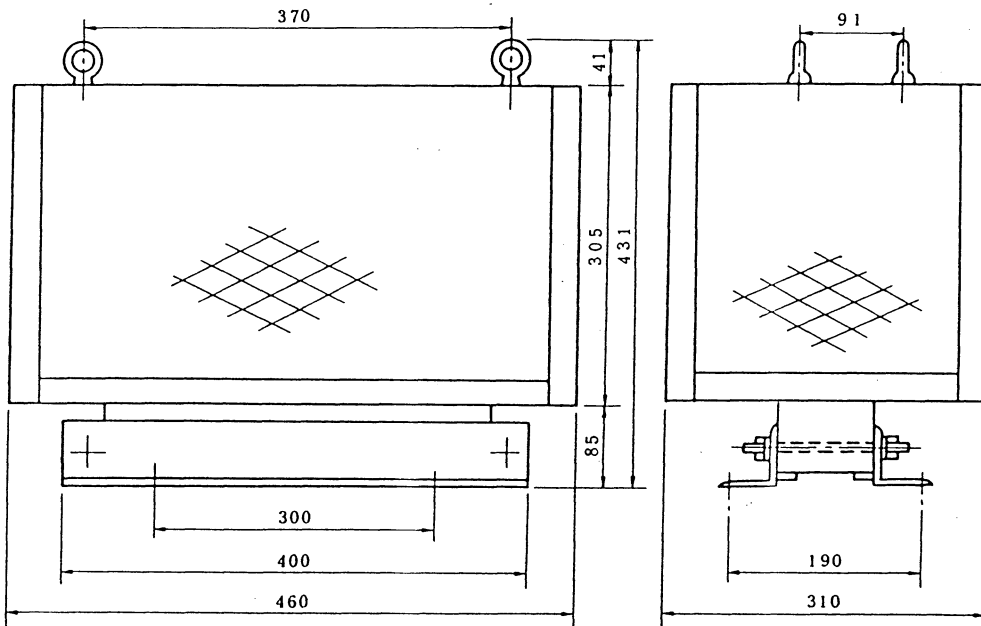

Note) Nets are covered on four sides and the plate is covered on the top.

Dimensions of transformer with cover (Models 6S, 8S)

8.1.14 Power transformer, models 12S, 15S (order specification: A06B-6044-J007)

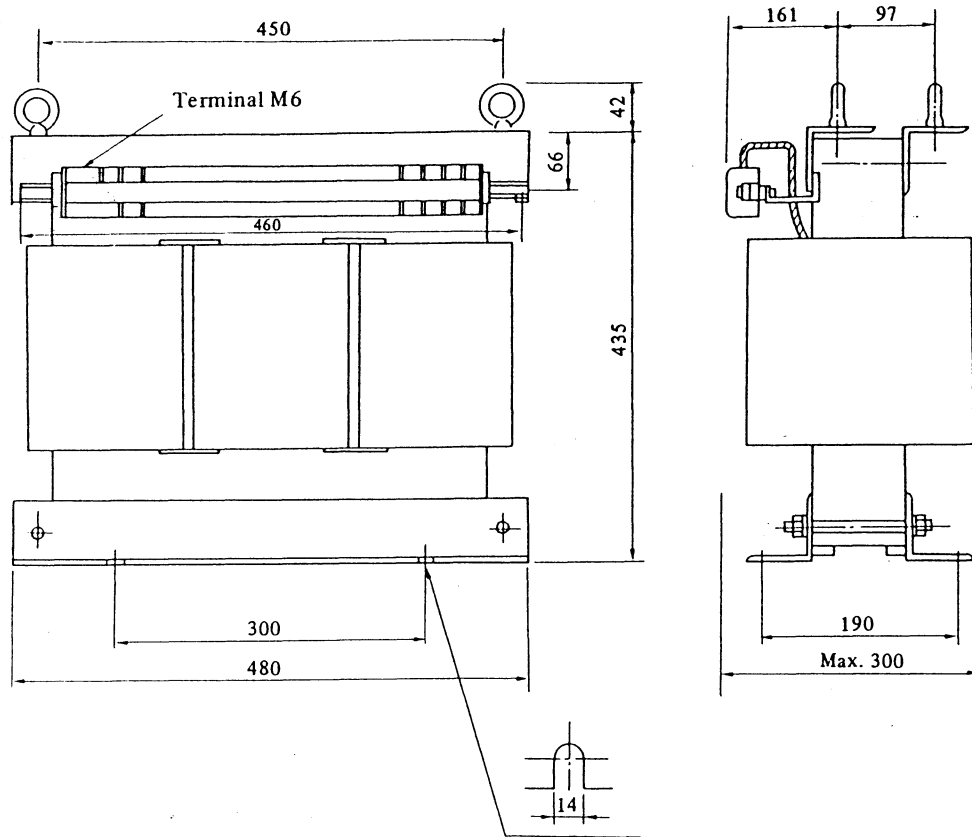

Dimensions of transformer without cover for models 12S, 15S

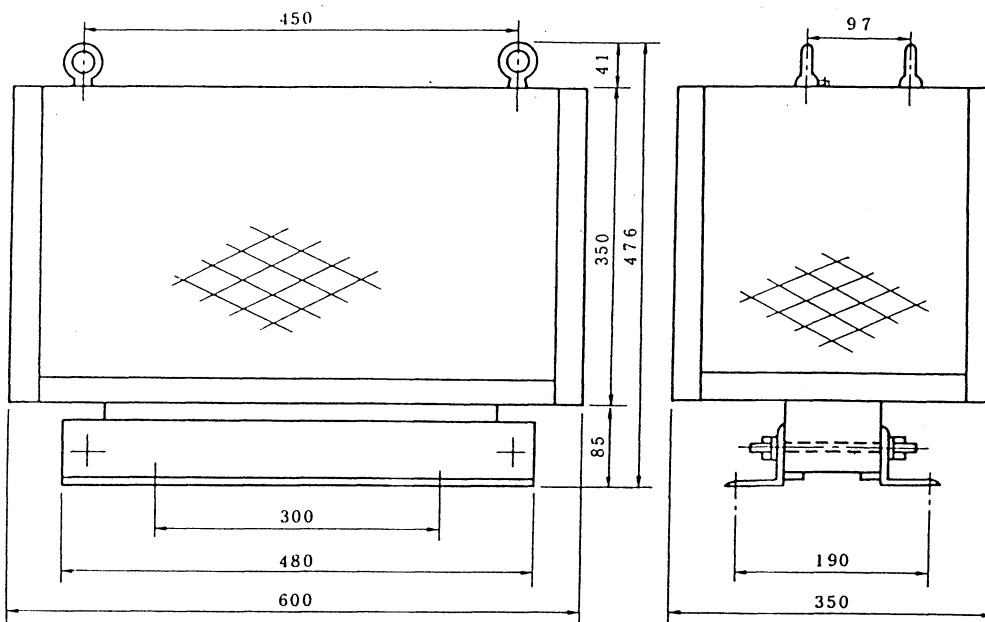

Note) Nets are covered on four sides and the plate is covered on the top.

Dimensions of transformer with cover for models 12S, 15S

8.1.15 Power transformer for Models 18S, 22S (order specification: A06B-6044-J010)

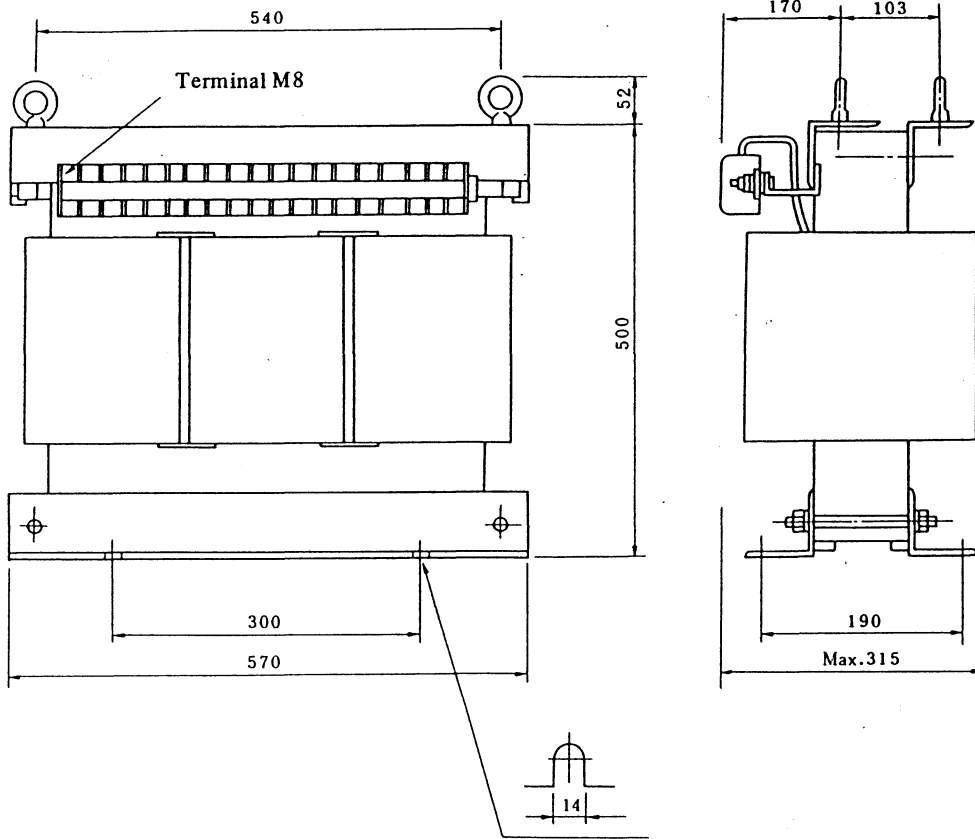

Dimensions of transformer without cover (Models 18S, 22S)

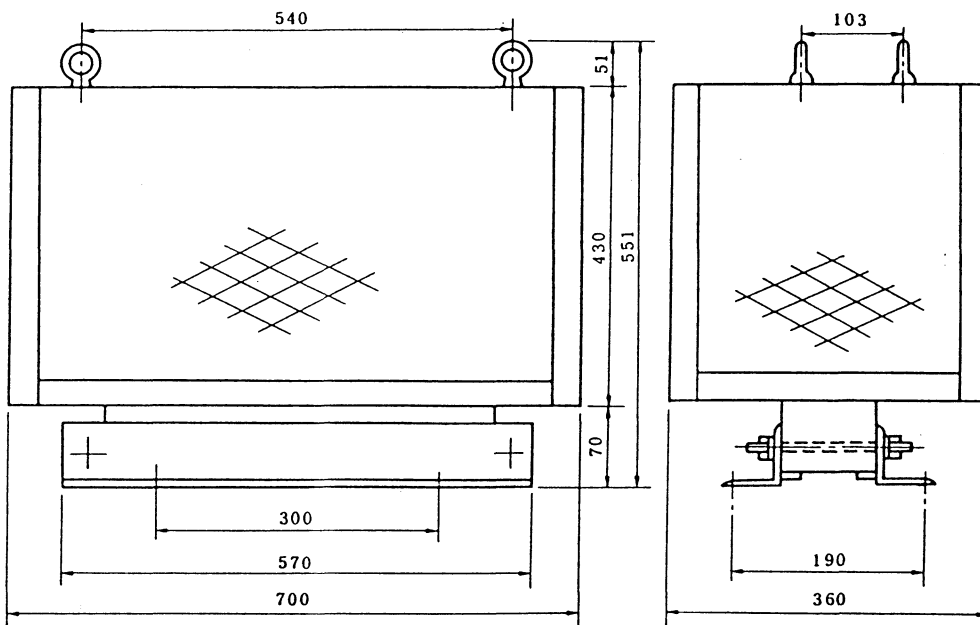

Note) Nets are covered on four sides and the plate is covered on the top.

Dimensions of transformer with cover (Models 18S, 22S)

8.2 Maintenance Area

8.2.1 AC spindle servo unit models 1S, 1.5S, 2S, 3S, 1S/15000, 2S/15000 (orientation using position coder)

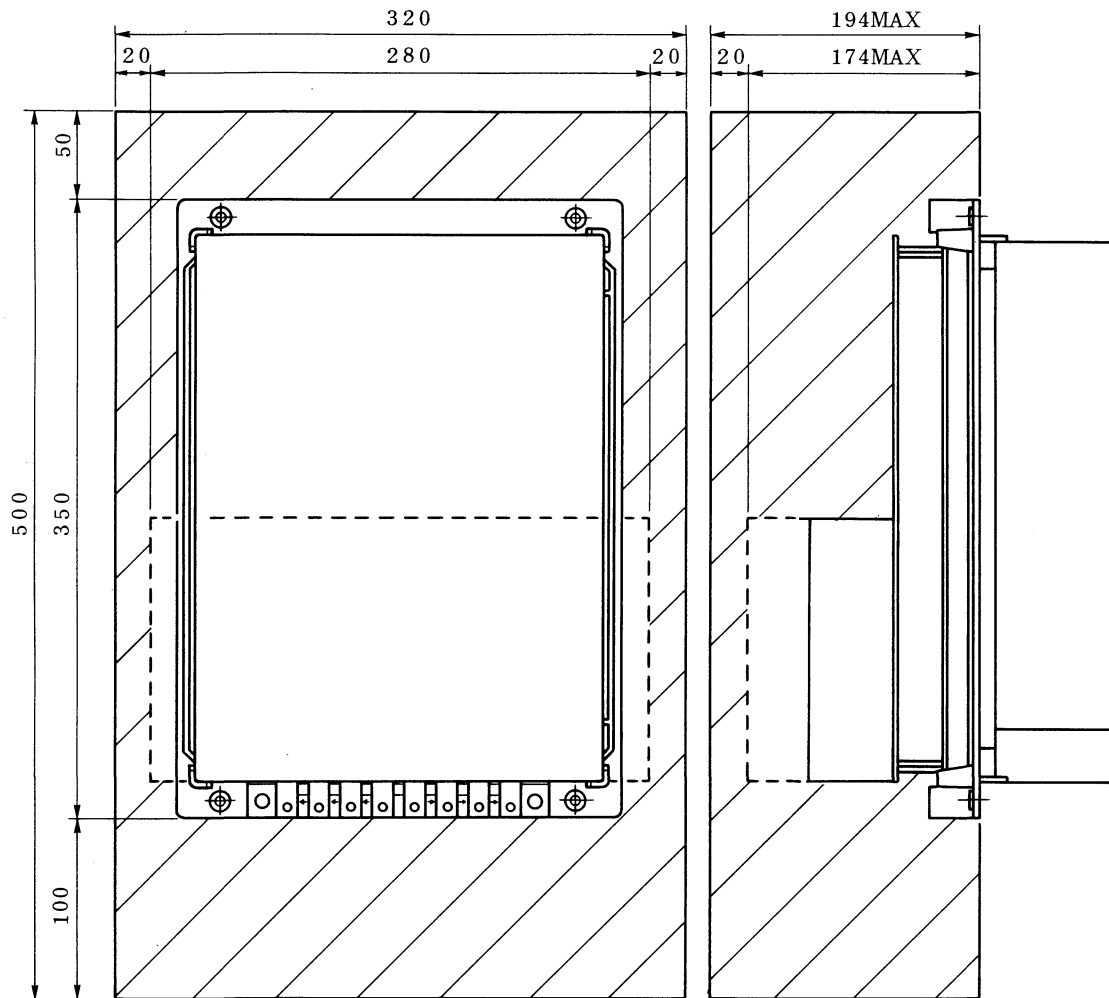

8.2.2 AC spindle servo unit models 1S, 1.5S, 2S, 3S, 1S/15000, 2S/15000 (orientation using magnetic sensor)

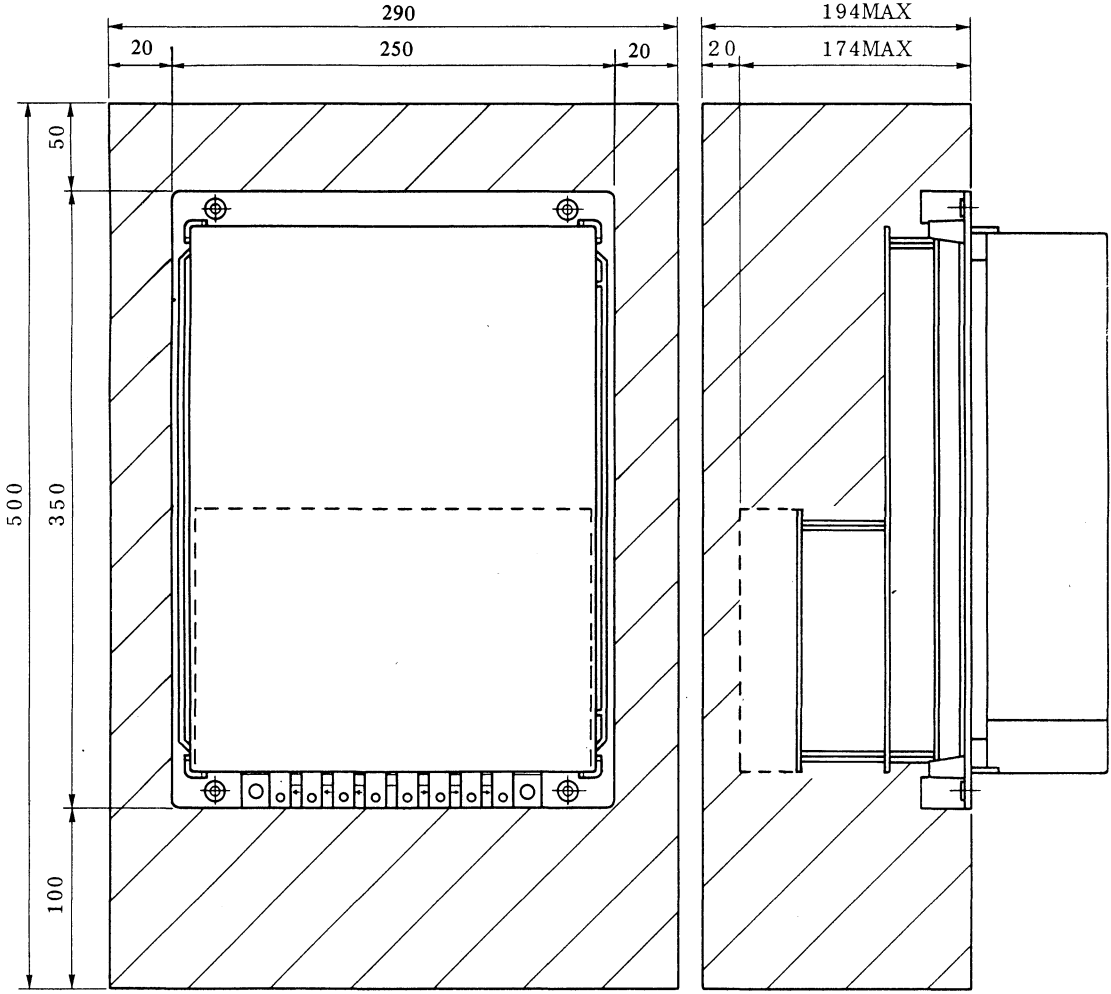

8.2.3 AC spindle servo unit model 6S, 8S, 12S, model 3S/12000, 6S/12000, 8S/8000, 12S/8000, model 8P, 12P, 15P, 18P, model 8VH (with unit adaptor)

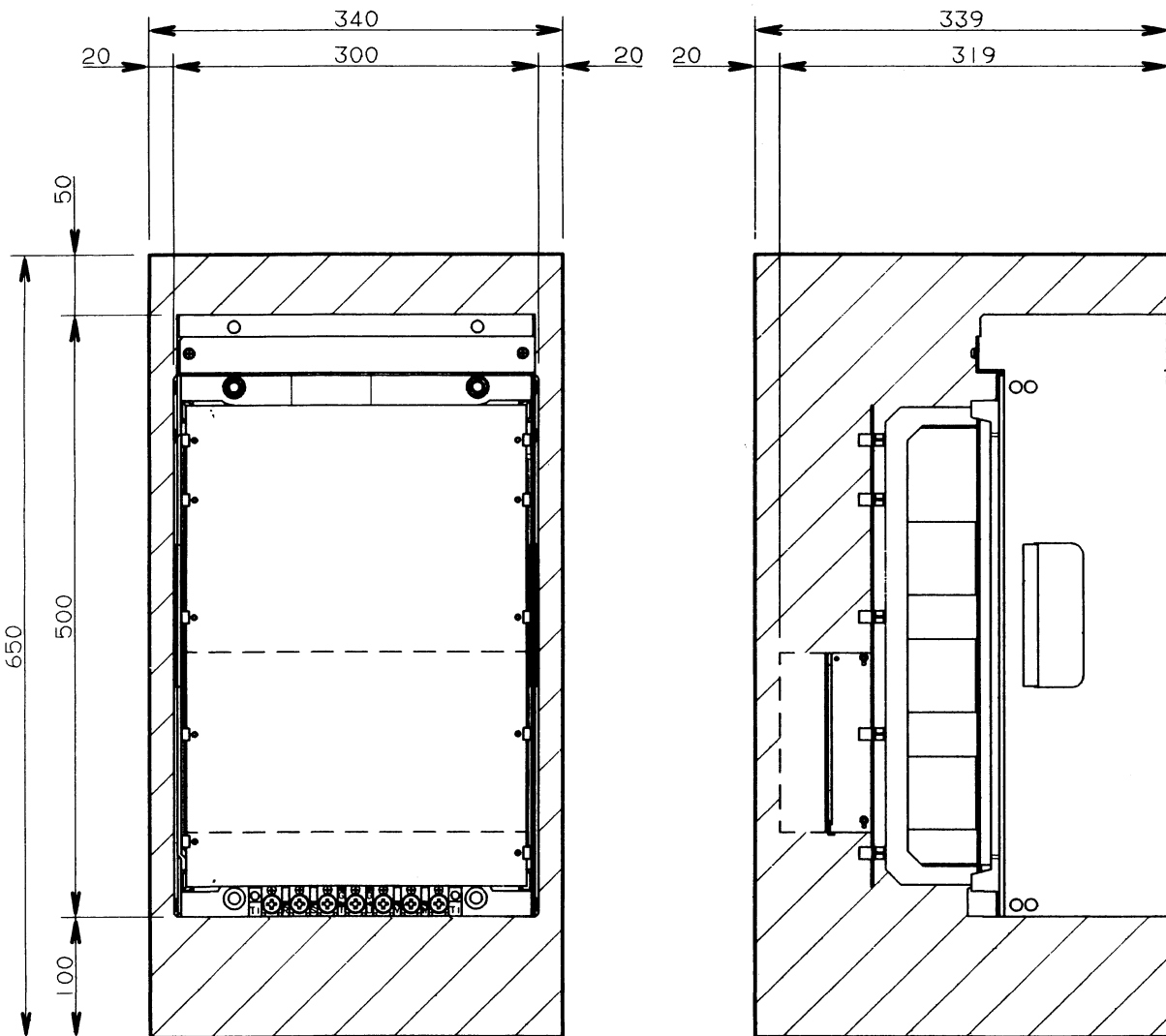

8.2.4 AC spindle servo unit model 6S, 8S, 12S, model 3S/12000, 6S/12000, 8S/8000, 12S/8000, model 8P, 12P, 15P, 18P, model 8VH (without unit adaptor)

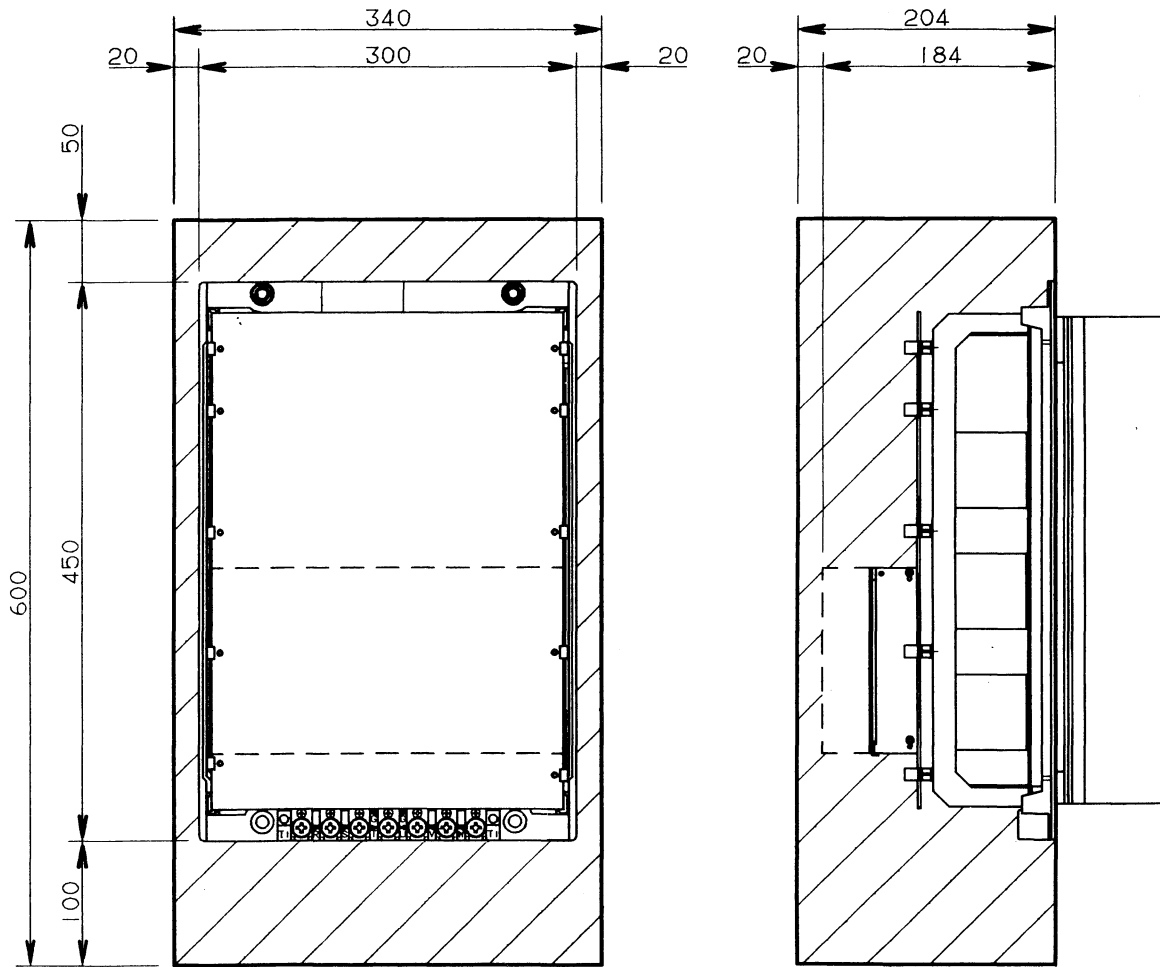

**8.2.5 AC spindle servo unit model 15S, 18S, 22S, model 15S/8000, 18S/6000, 22S/6000,
model 22P, 30P, model 12VH (with unit adaptor)**

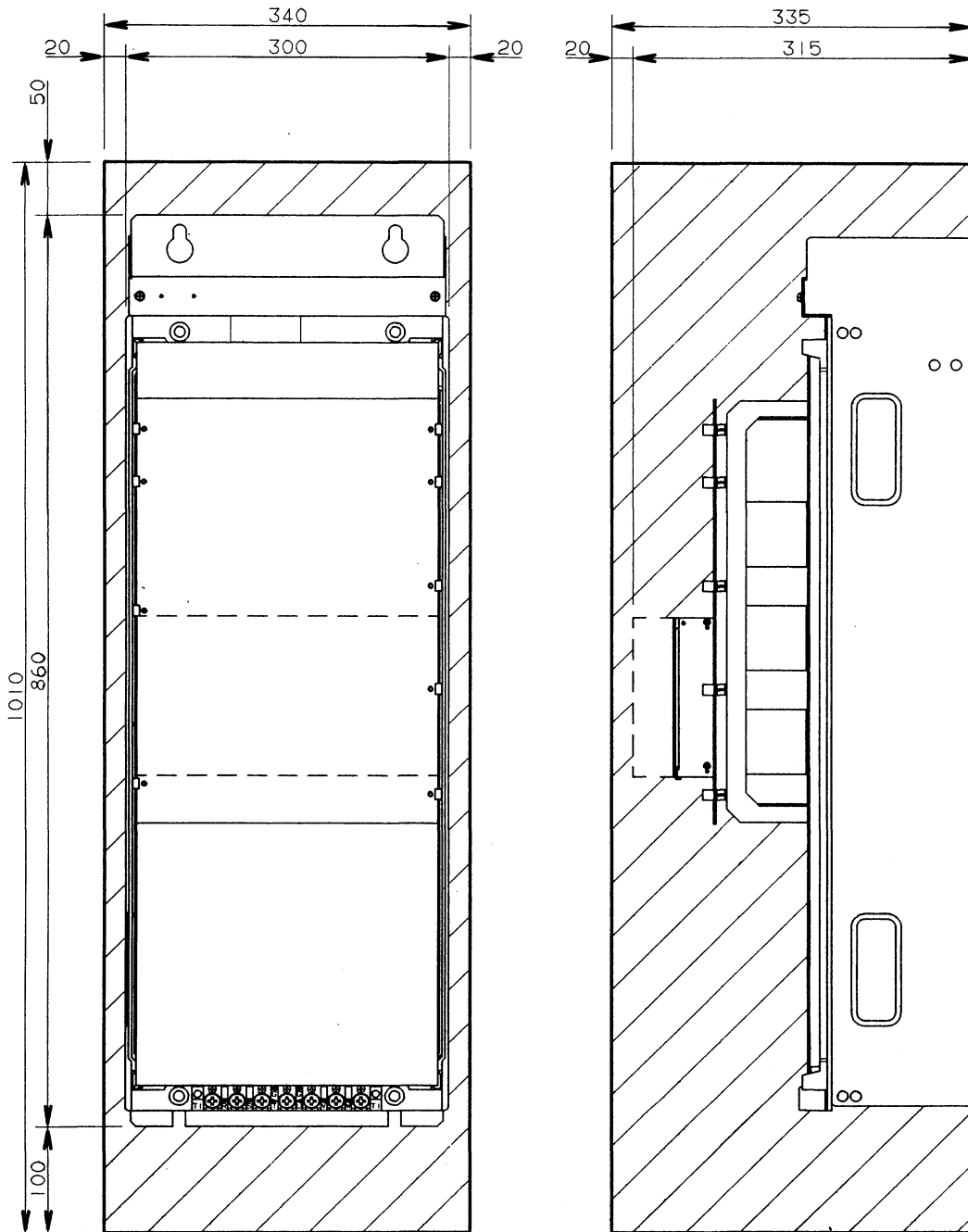

8.2.6 AC spindle servo unit model 15S, 18S, 22S, model 15S/8000, 18S/6000, 22S/6000, model 22P, 30P, 40P, model 12VH (without unit adaptor)

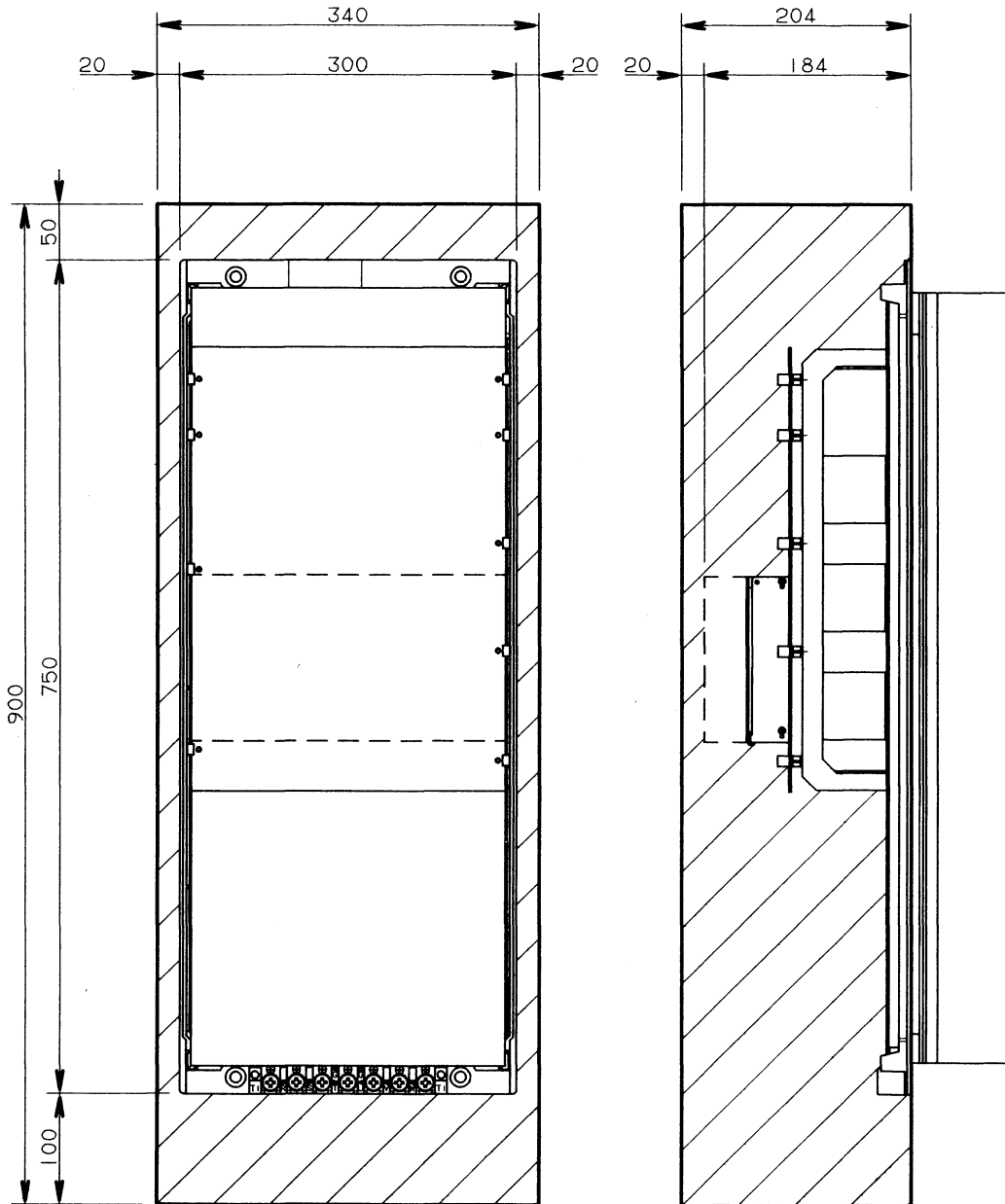

8.3 Panel Hole Machining Diagram and Mounting

8.3.1 AC spindle servo unit model 1S, 1.5S, 2S, 3S, model 1S/15000, 2S/15000

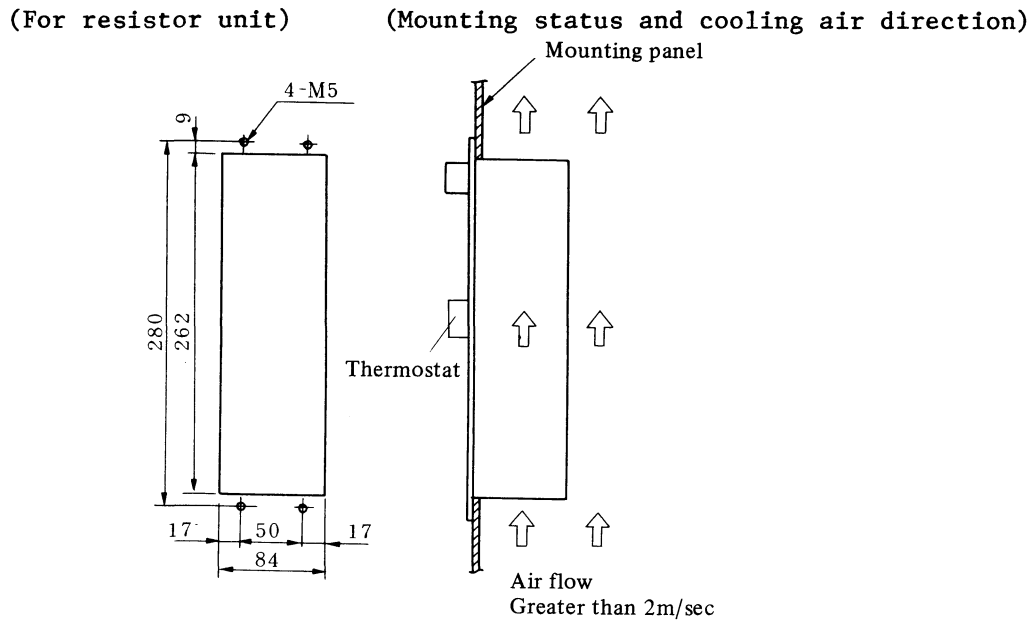

. Panel hole machining diagram and mounting diagram

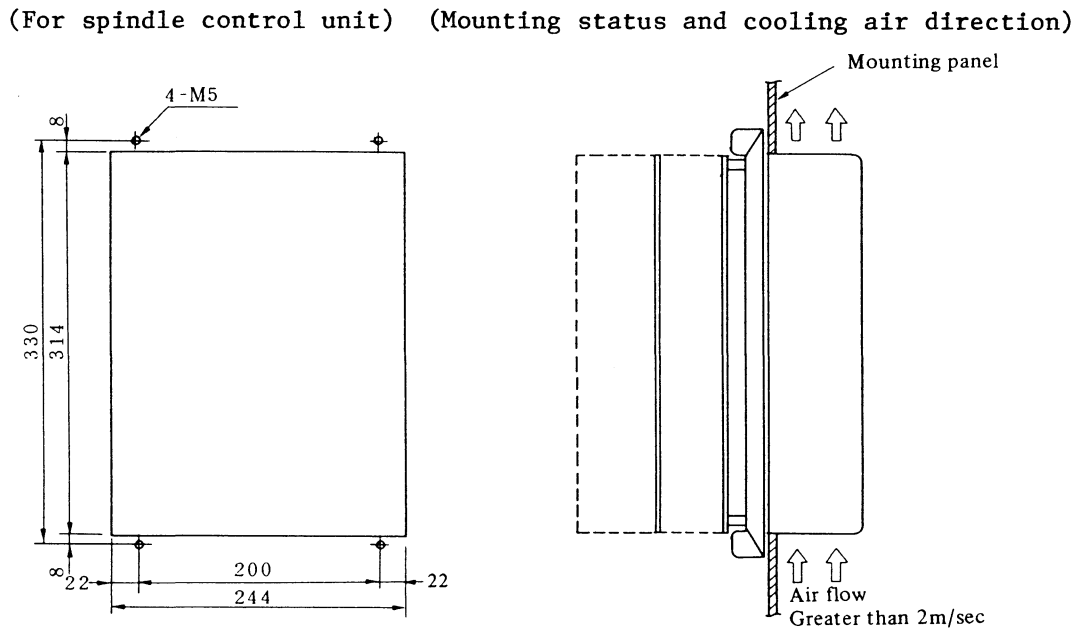

Note) The cooling fan is not provided for the spindle control unit and resistor unit. Cool the radiator using a fan having greater than 2 m/sec. of air flow.

It is recommended to provide a packing (acrylonitrile-butadiene rubber, NBR (soft type)) to protect oil and dust by the MTB.

8.3.2 AC spindle servo unit model 6S, 8S, 12S, model 3S/12000, 6S/12000, 8S/8000, 12S/8000, model 8P, 12P, 15P, 18P, model 8VH

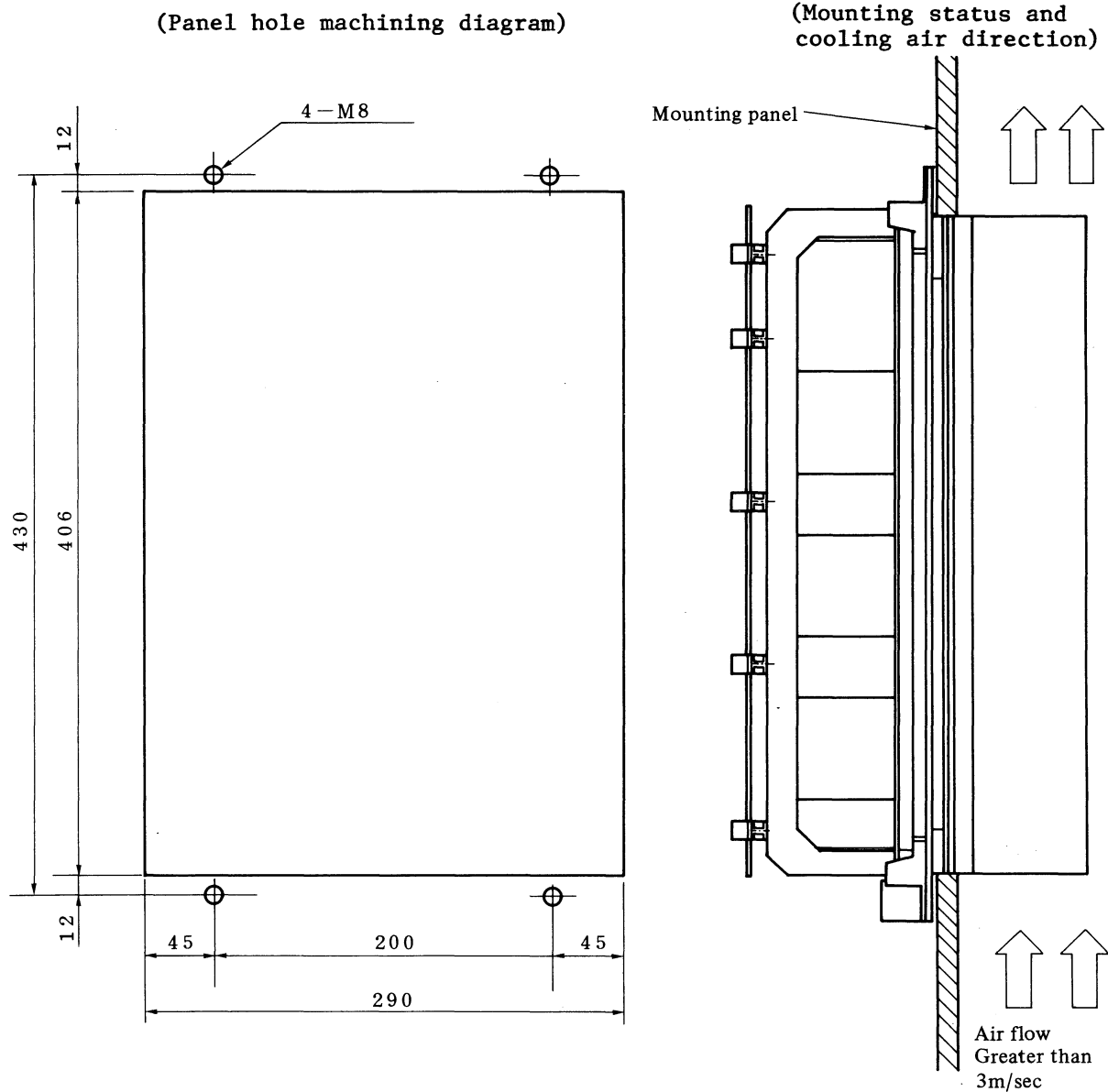

Note) The cooling fan is not provided for the spindle control unit. Cool the radiator using a fan having greater than 3 m/sec. of air flow.

It is recommended to provide a packing (acrylonitrile-butadiene rubber, NBR, soft type) illustrated in the figure above to protect from oil and dust by the MTB.

8.3.3 AC spindle servo unit model 15S, 18S, 22S, model 15S/8000, 18S/6000, 22S/6000, model 22P, 30P, 40P, model 12VH

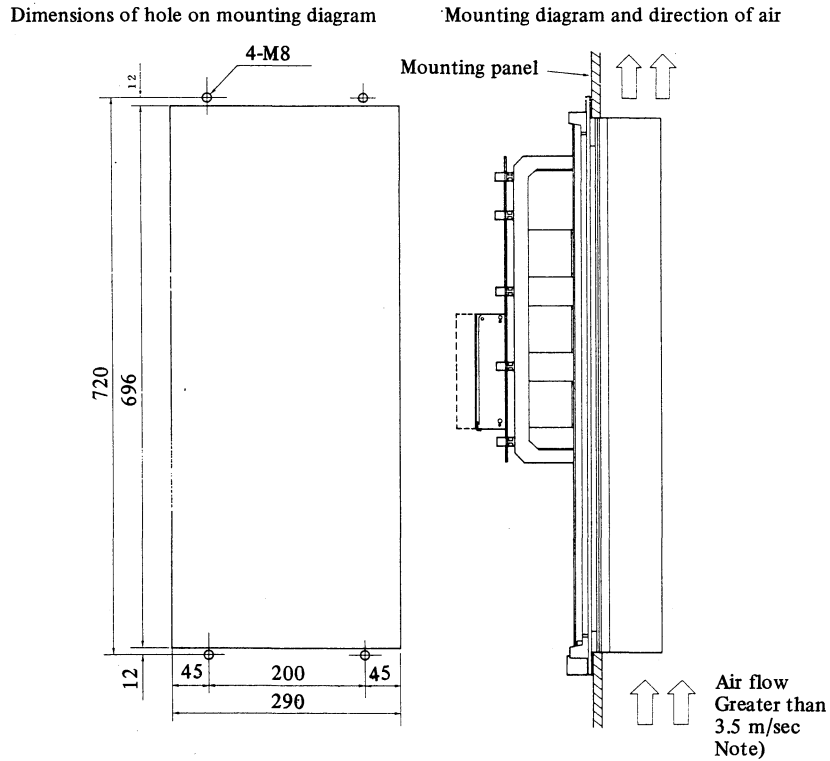

Note) The cooling fan is not provided for the spindle control unit. Cool the radiator using a fan having greater than 3.5 m/sec. of air flow. However, for the model 40P, refer to the items related to "Spindle Motor P series" in Part III.

It is recommended to provide a packing (acrylonitrile-butadiene rubber, NBR, soft type) illustrated in the figure above to protect from oil and dust by the MTB.

9. CONNECTION

9.1 Connection Diagram

9.1.1 Models 1S - 3S, 1S/15000, 2S/15000

(i) Resistor unit A06B-6052-K050 is used.

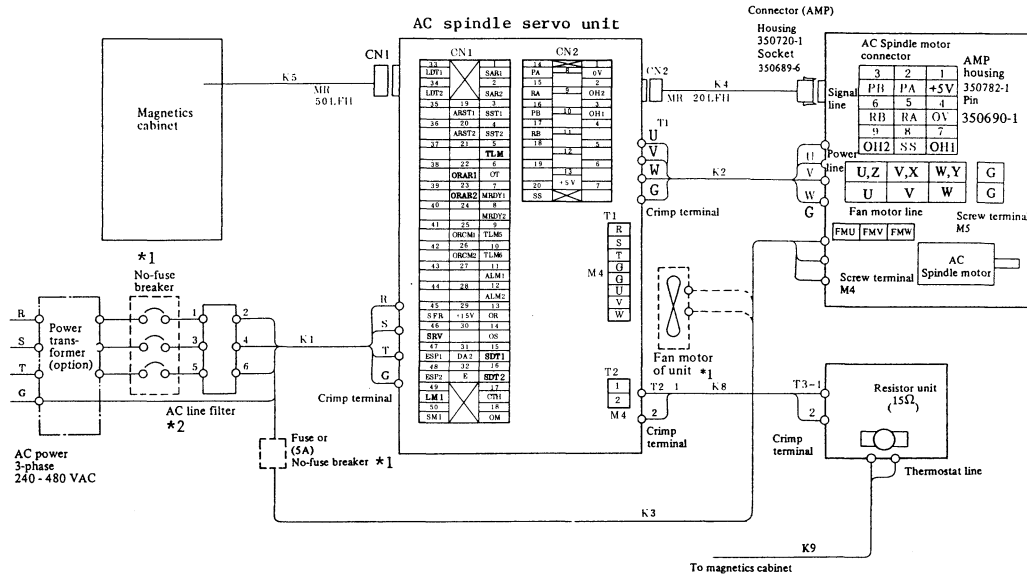

*1 Unit fan motor and breaker are provided by the MTB.

*2 Use AC line filter without fail when power transformer is not used.

(ii) Resistor unit A06B-6052-K051 is used (in parallel with 30Ω)

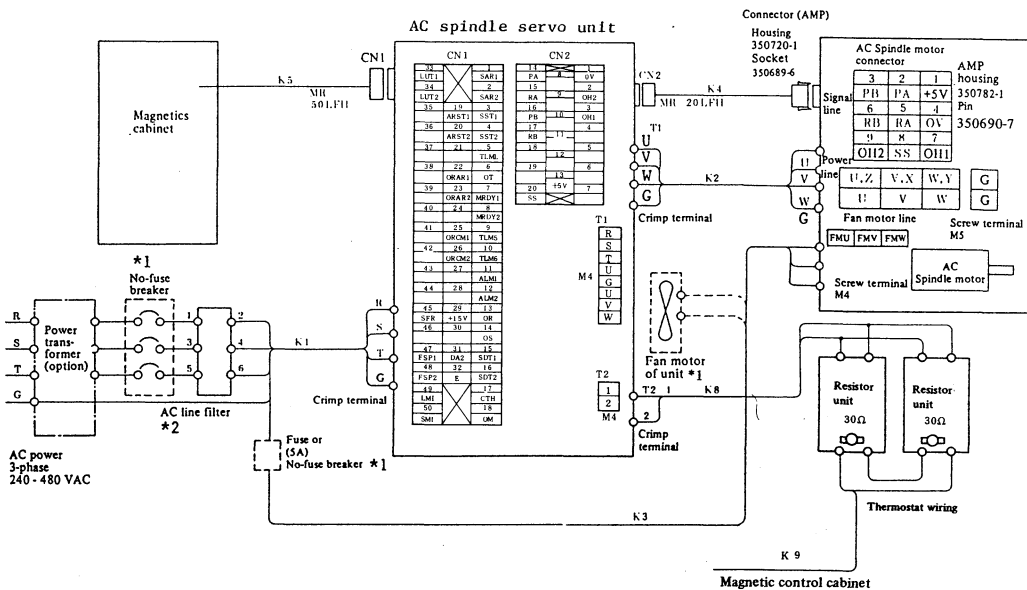

*1 Unit fan motor and breaker are provided by the MTB.

*2 Use AC line filter without fail when power transformer is not used.

(iii) 4 resistor units A06B-6052-K050 are used

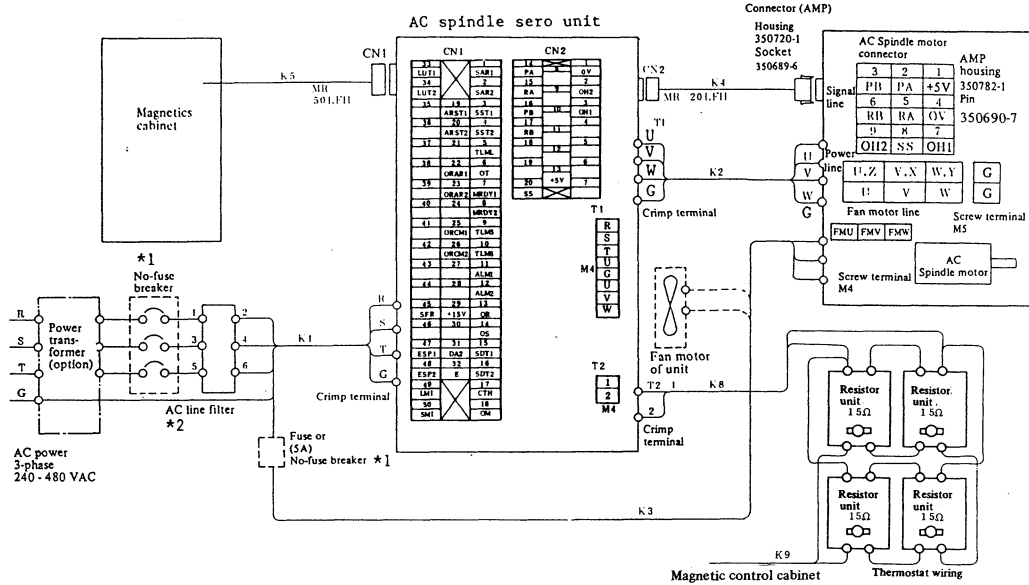

*1 Unit fan motor and breaker are provided by the MTB.

*2 Use AC line filter without fail when power transformer is not used.

9.1.2 Models 6S - 22S, 3S/12000 - 22S/6000, 8P - 40P, 8VH, 12VH

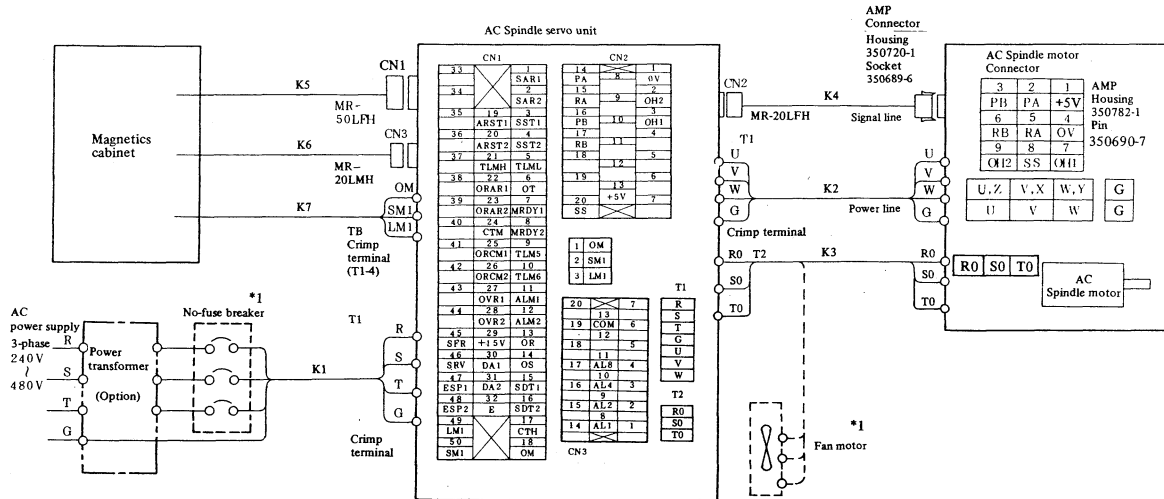

*1 Unit fan motor and breaker are provided by the MTB.

*2 On the PCBs with a version No. of 10B or later, CN1-39, 41, 43, CN-3-15 and 16 are deleted.

9.2 Cable Routing

Refer to Appendix, Cable Routing Specifications

9.2.1 Cable routing diagram of models 1S - 3S, 1S/15000, 2S/15000

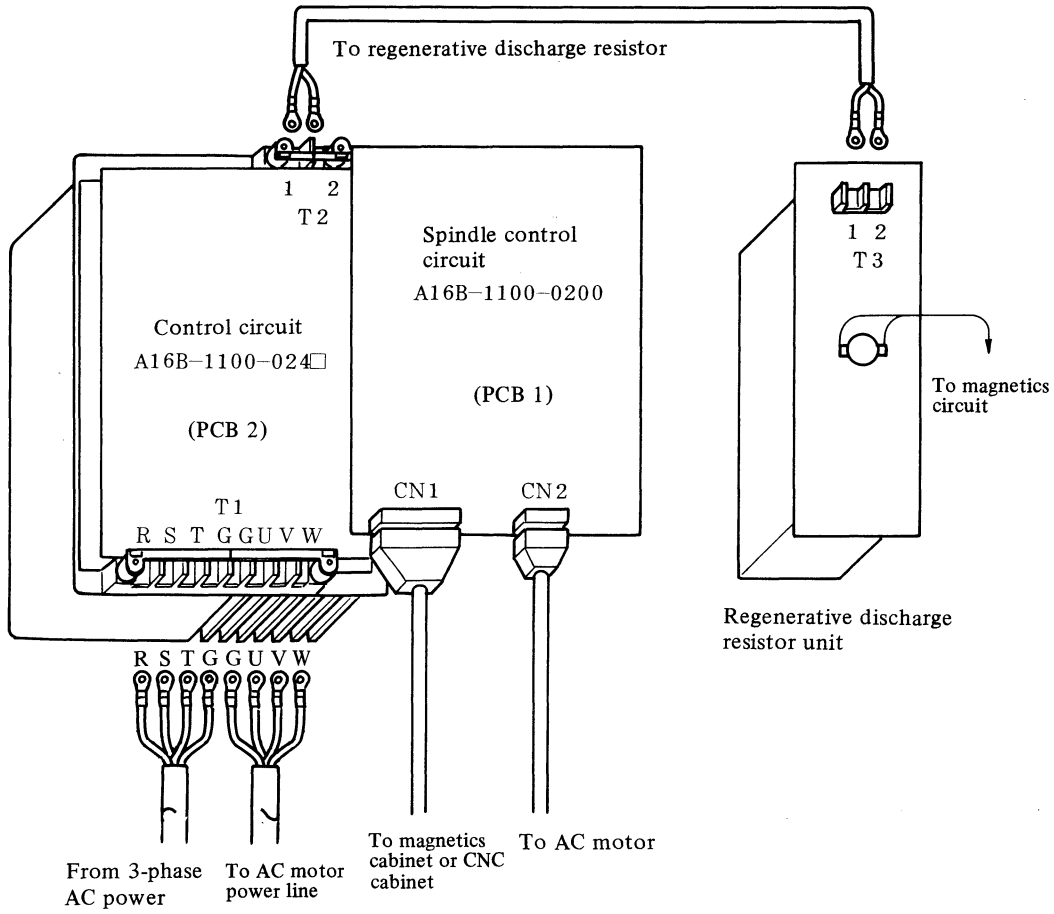

Fig. 9.2.1 Cable routing diagram of models 1S - 3S, 1S/15000, 2S/15000

9.2.2 Cable routing diagram of models 6S - 12S, 3S/12000, 6S/12000, 8S/8000, 12S/8000, 8P, 12P, 15P, 8VH

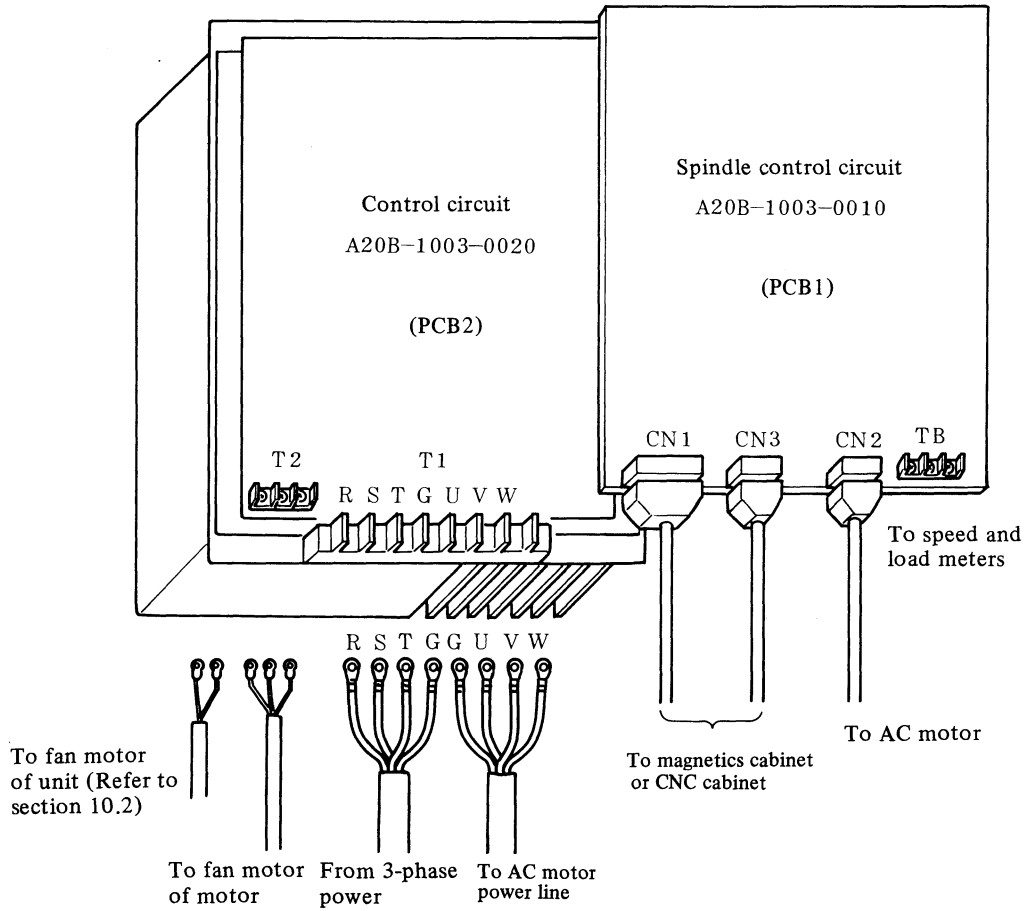

Fig. 9.2.2 Cable routing (Models 6S - 12S, 3S/12000, 6S/12000, 8S/8000, 12S/8000, 8P, 12P, 15P, 8VH)

9.2.3 Cable routing diagram of models 15S - 22S, 15S/8000, 18S/6000, 22S/6000, 22P, 30P, 40P, 12VH

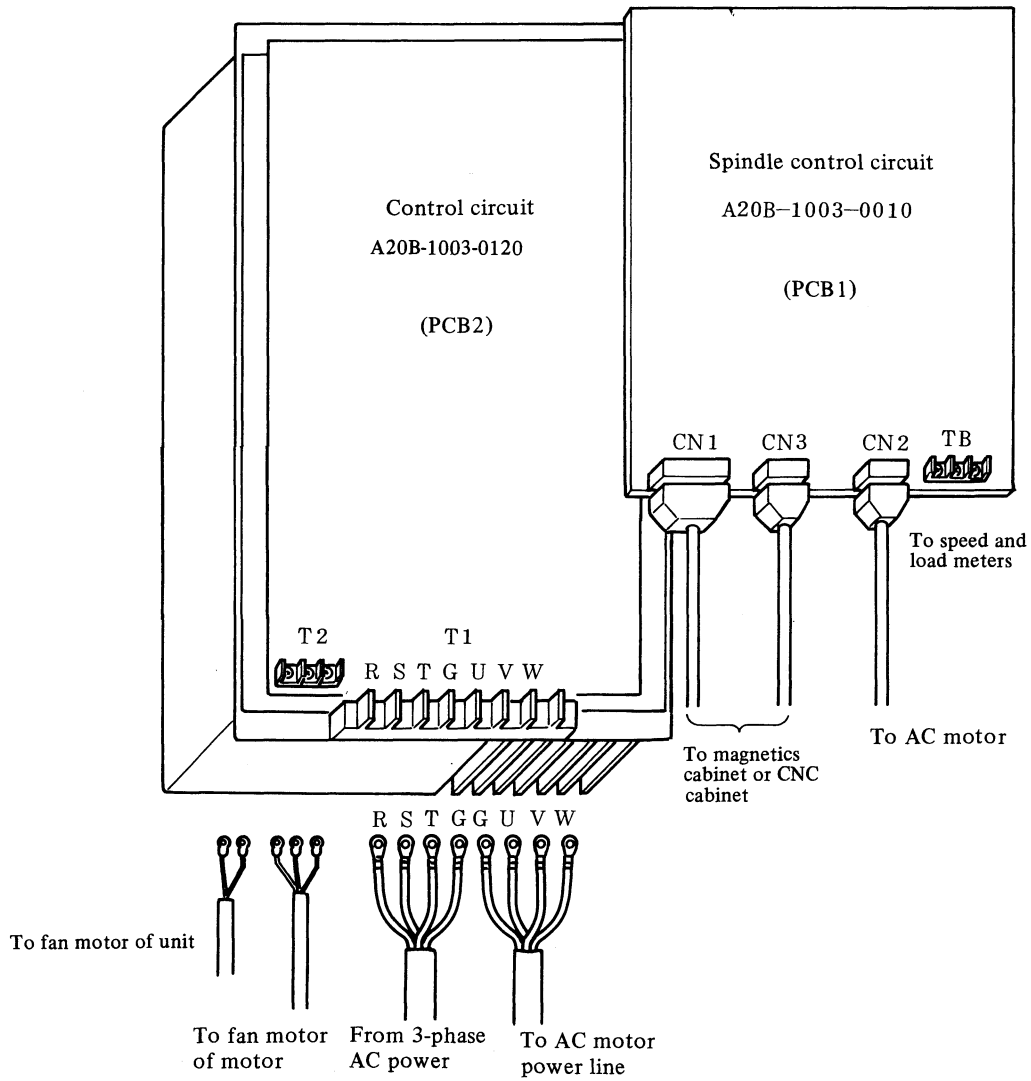
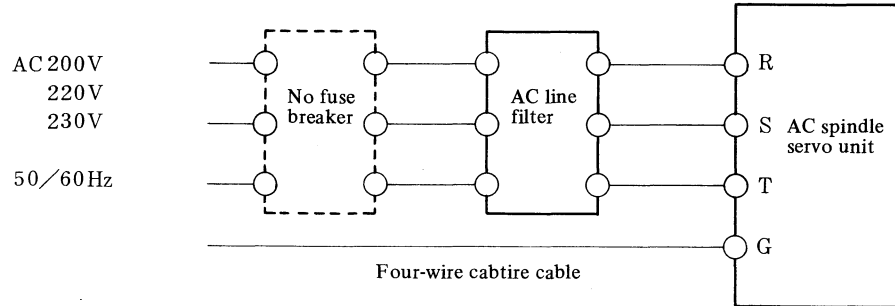

Fig. 9.2.3 Cable routing (Models 15S - 22S, 15S/8000, 18S/6000, 22S/6000, 22P, 30P, 40P, 12VH)

9.3 Detailed Connection Diagram

9.3.1 Connection of power source

- (1) AC spindle servo unit Models 1S - 3S, 1S/15000, 2S/15000
 . Without power transformer



- . With power transformer

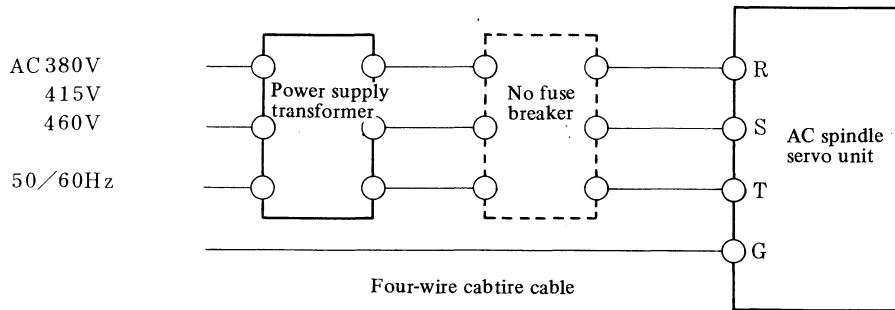

Model	Applicable wire	Unit terminal screw
1S	Greater than 2 mm ²	M4
1.5S	Greater than 3.5 mm ²	
2S, 1S/15000, 2S/15000	Greater than 3.5 mm ²	
3S	Greater than 5.5 mm ²	

(2) AC spindle servo unit Models 6S - 22S, 3S/12000 - 22S/6000, 8P - 40P, 8VH, 12VH

. Without power transformer

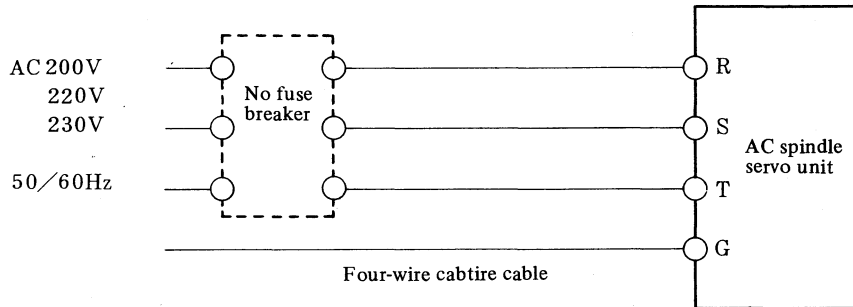

. With power transformer

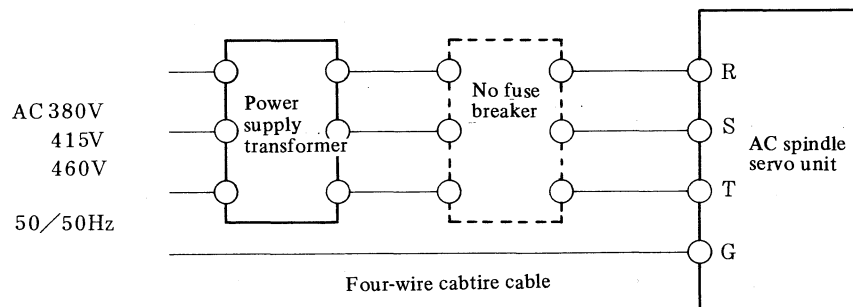

Model	Applicable wire	Unit terminal screw
6S, 3S/12000, 8P, 12P	Greater than 8 mm ²	M5
8S,12S, 6S/12000, 8S/8000, 12S/8000, 15P, 18P, 8VH	Greater than 14 mm ²	
15S, 15S/8000, 22P, 12VH	Greater than 14 mm ² (Note)	M8
18S,22S, 18S/6000, 22S/6000, 30P, 40P, 50P	Greater than 22 mm ² (Note)	

Note) Use the flame retardant poli-flex cable (MLFC)
(Maximum temperature of conductor: 105°C)

9.3.2 Connection of AC spindle servo unit and magnetics cabinet

(1) Models 1S - 3S, 1S/15000, 2S/15000

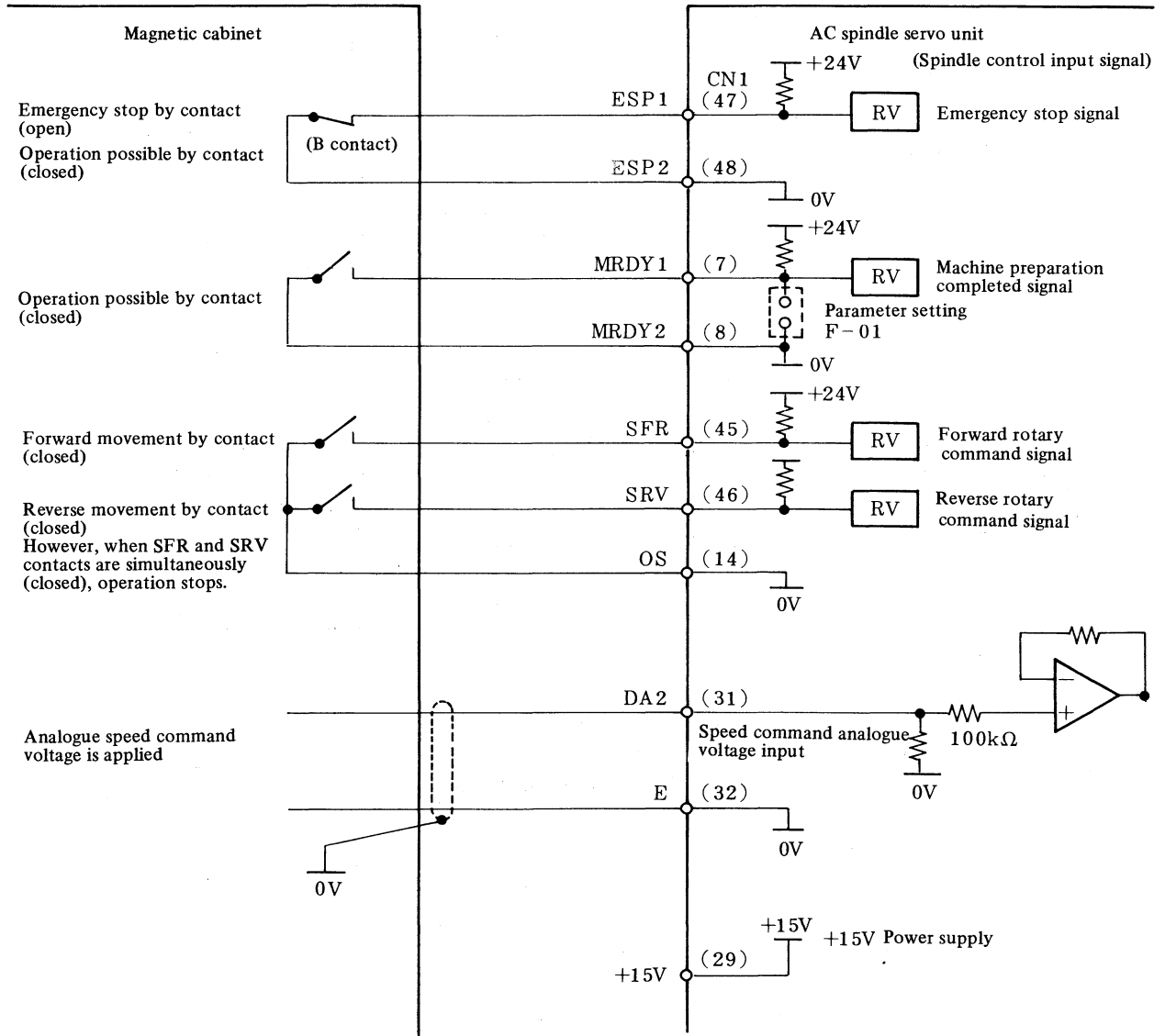

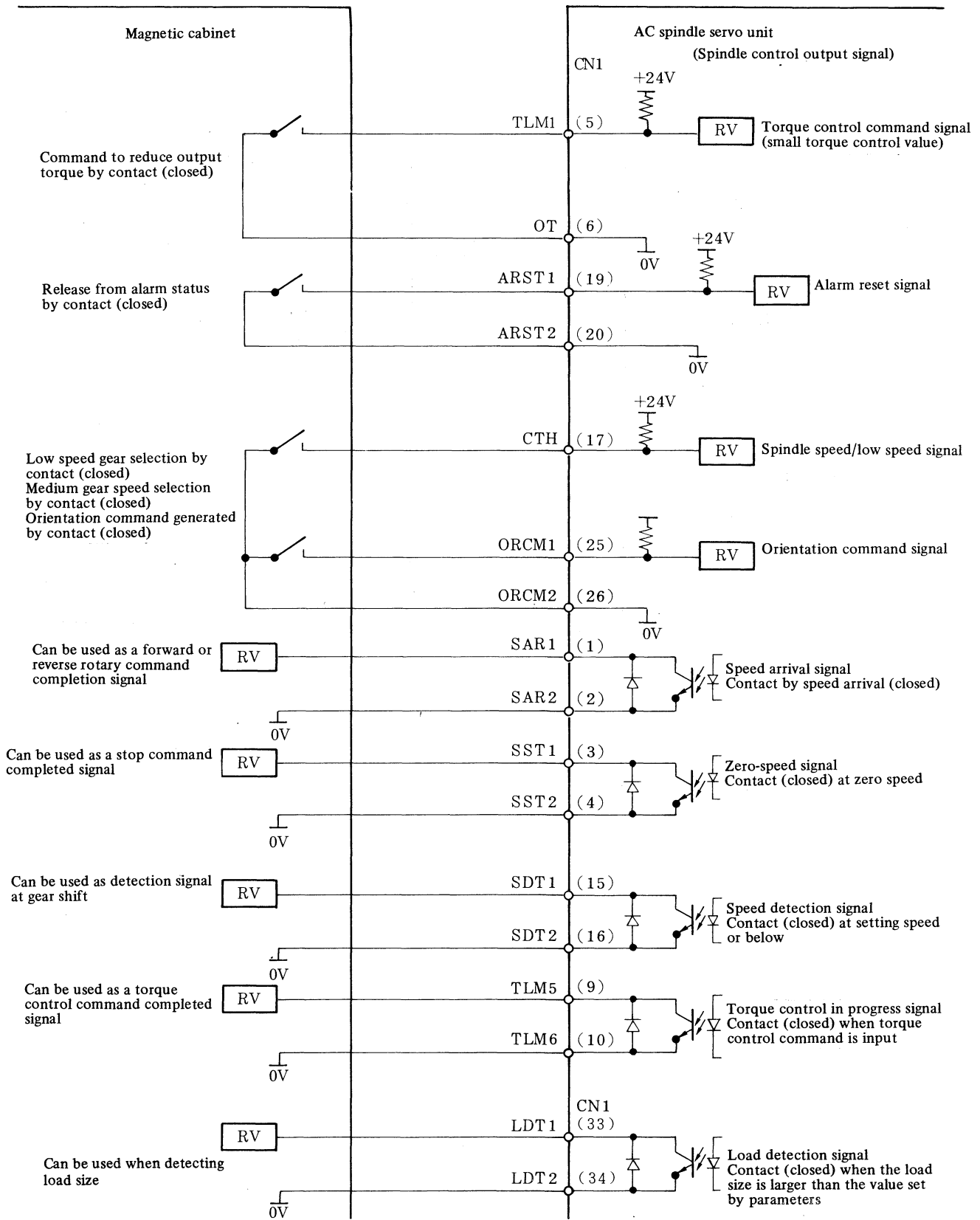

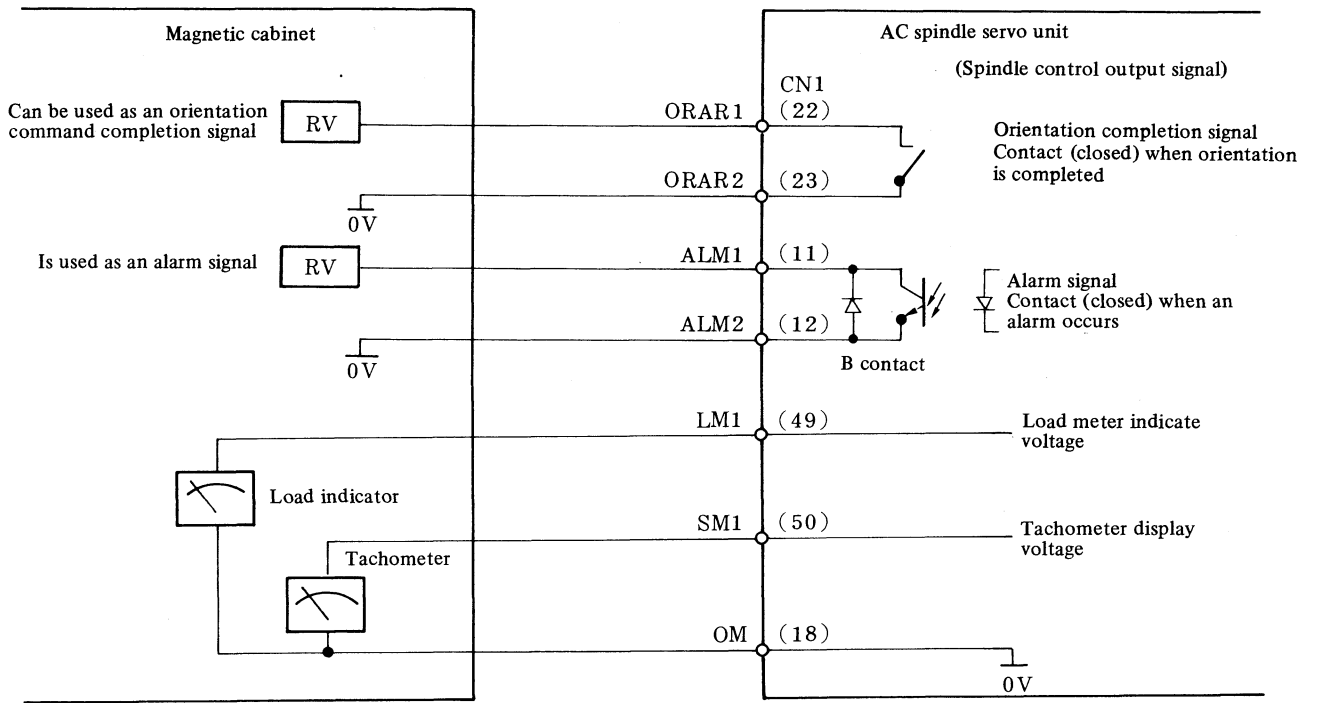

(2) Models 6S - 22S, 3S/12000 - 22S/6000, 8P - 40P, 8VH, 12VH

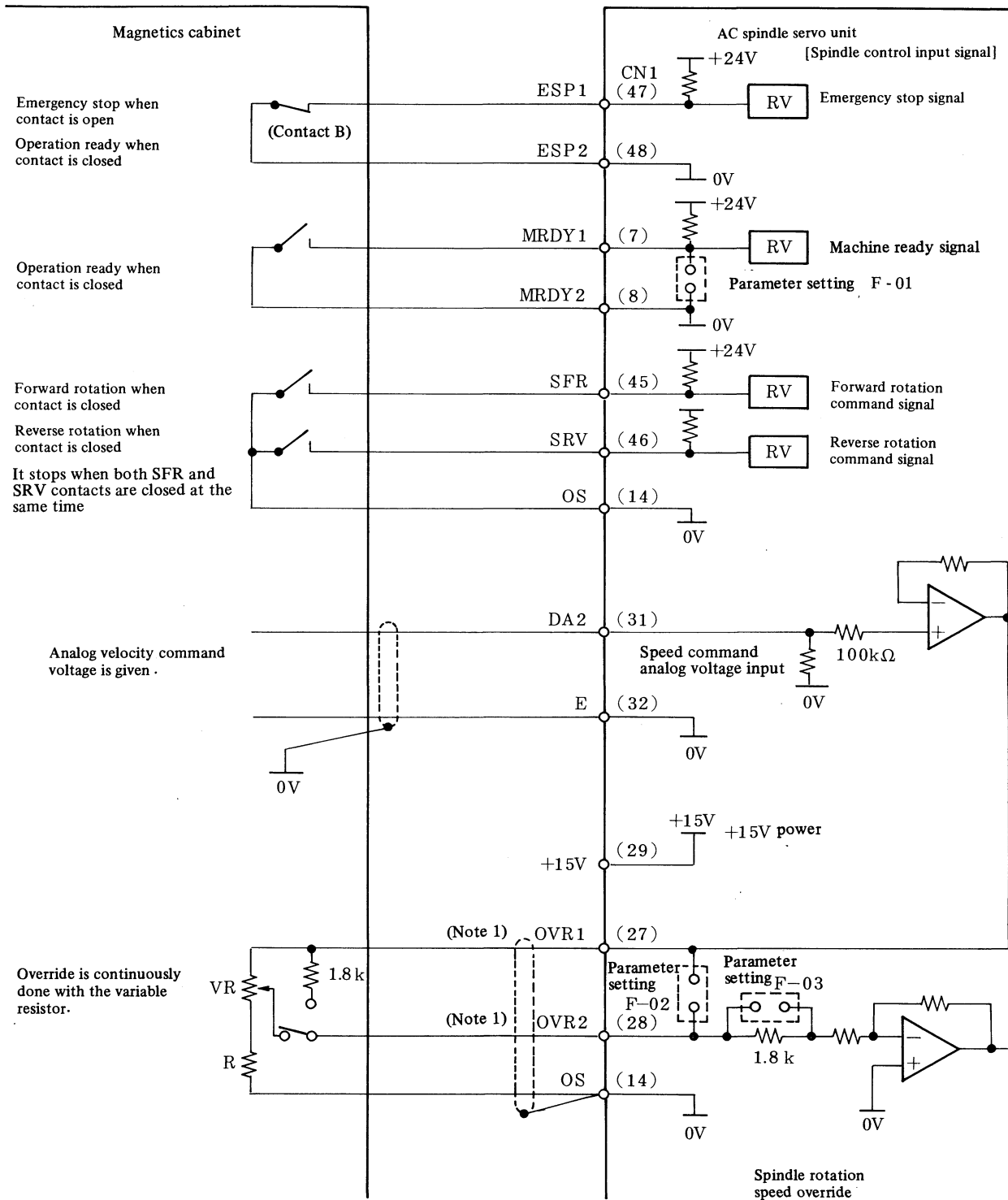

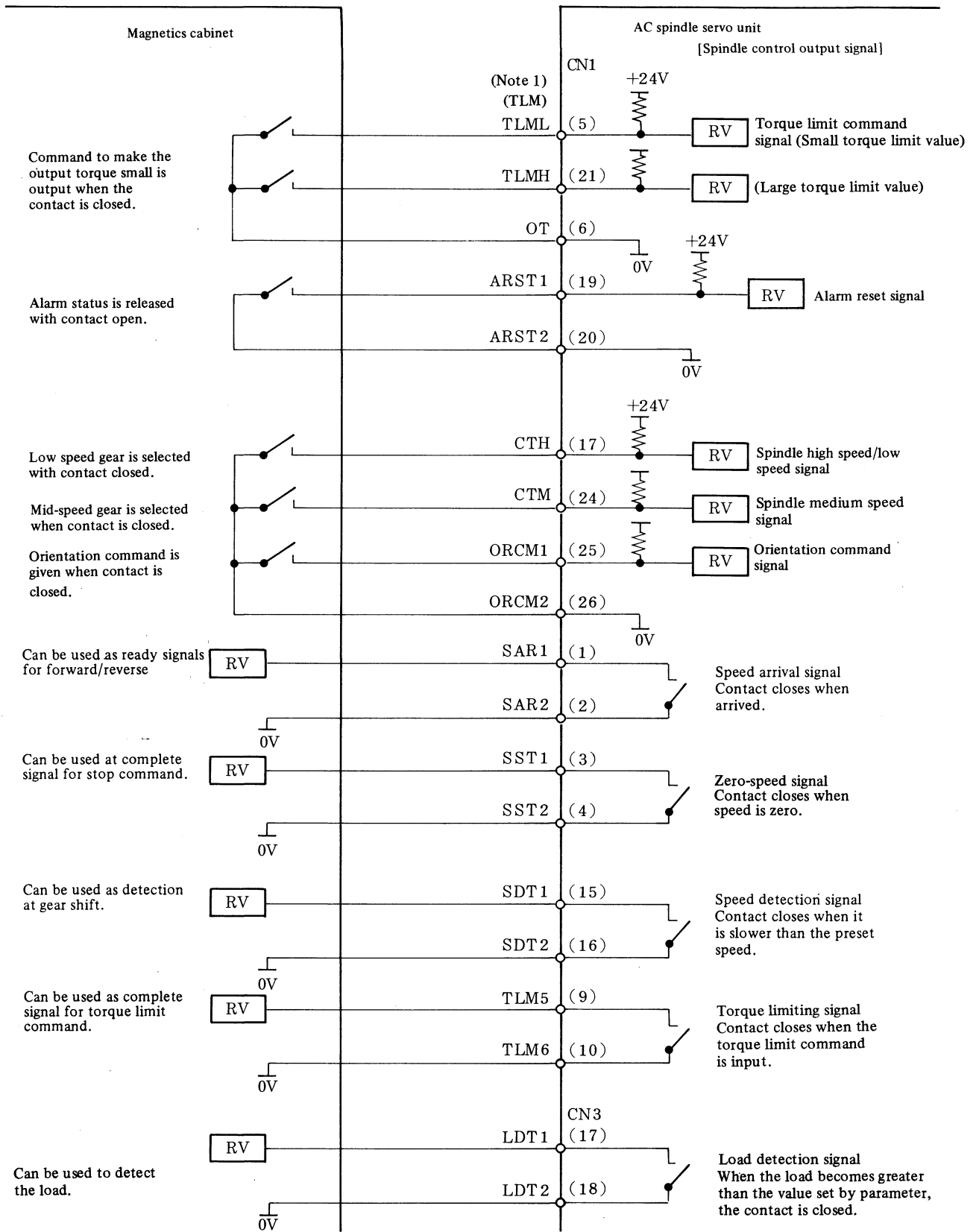

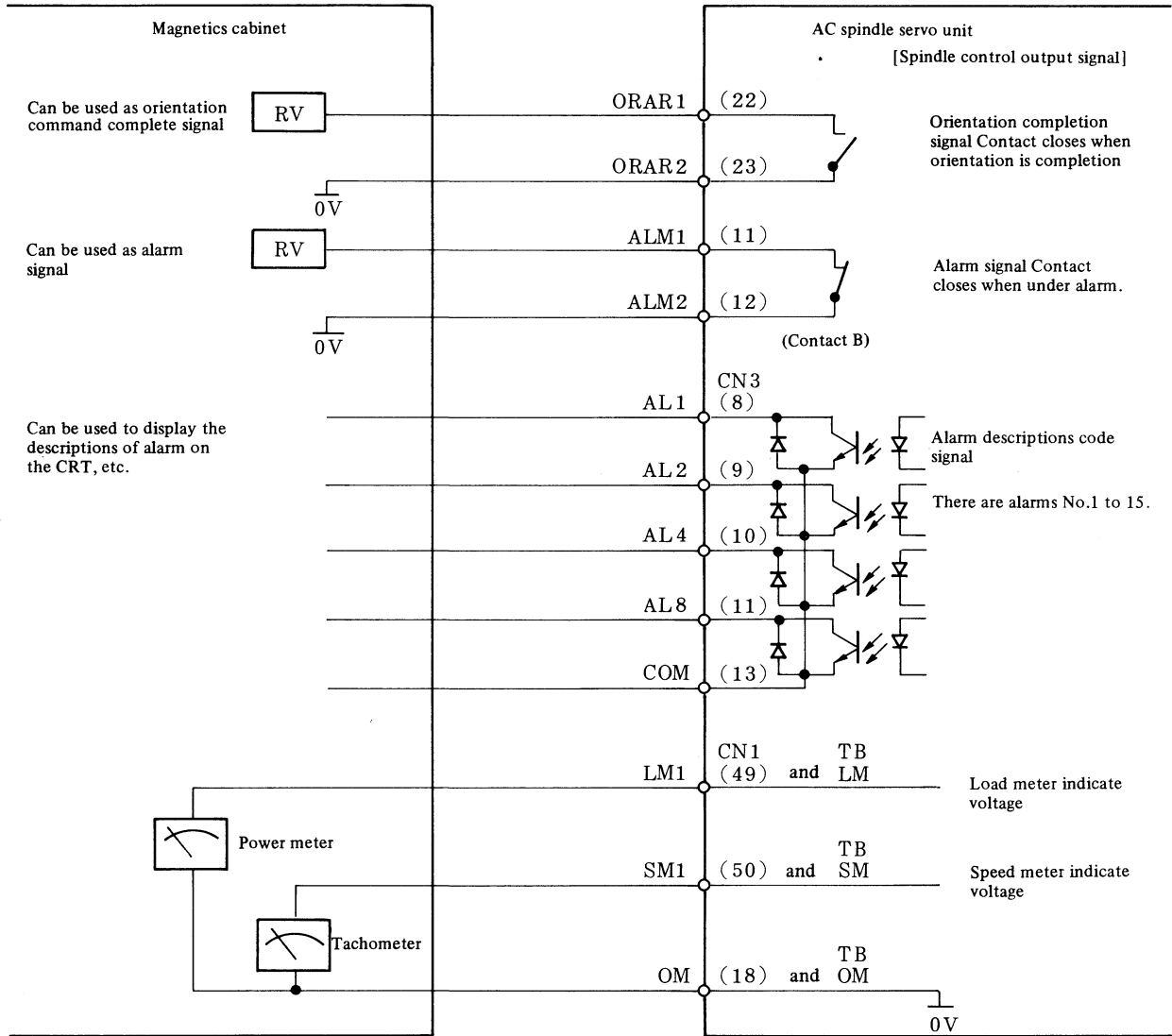

9.3.3 Connection of AC spindle servo unit and AC spindle motor
 (1) Models 1S - 3S, 1S/15000, 2S/15000

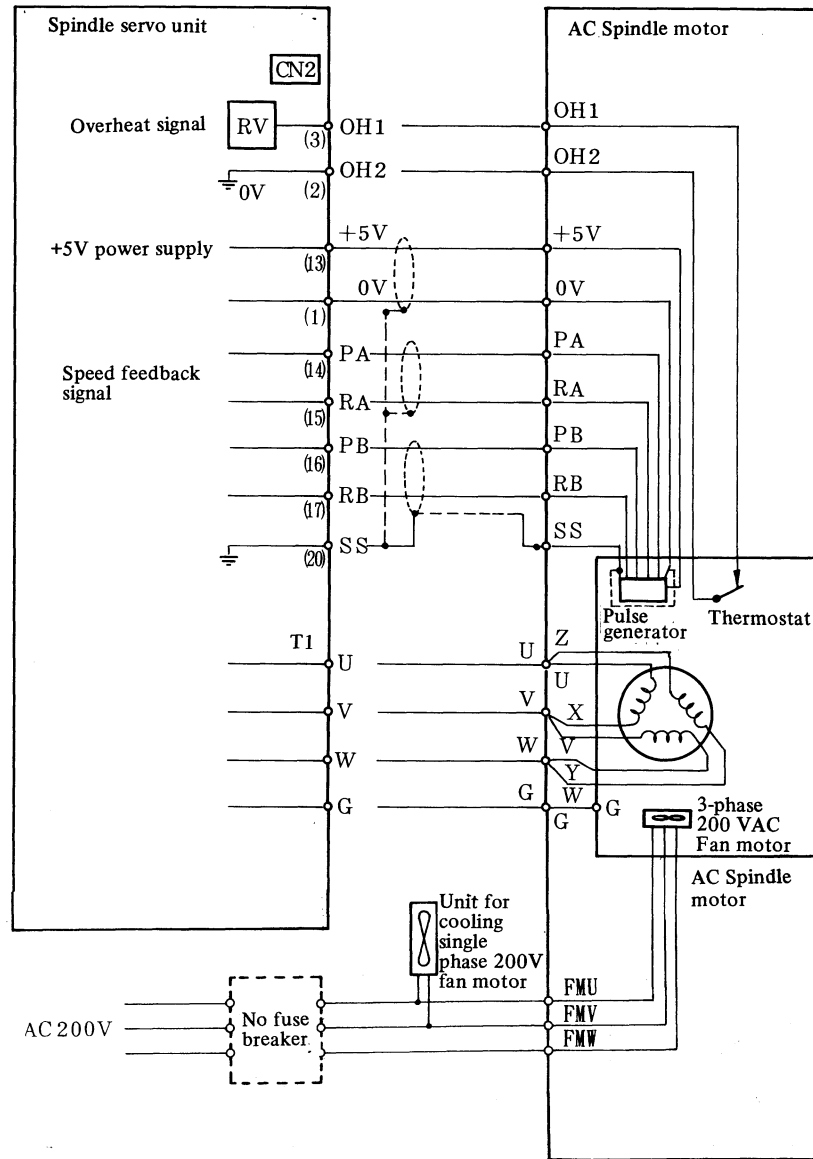

- . The power source of the unit and the fan motor for cooling the motor is to be connected to the no-fuse breaker.
- . Fan motor for cooling the unit is provided by the MTB.

(2) Models 6S - 22S, 3S/12000 - 22S/6000, 8P - 40P, 8VH, 12VH

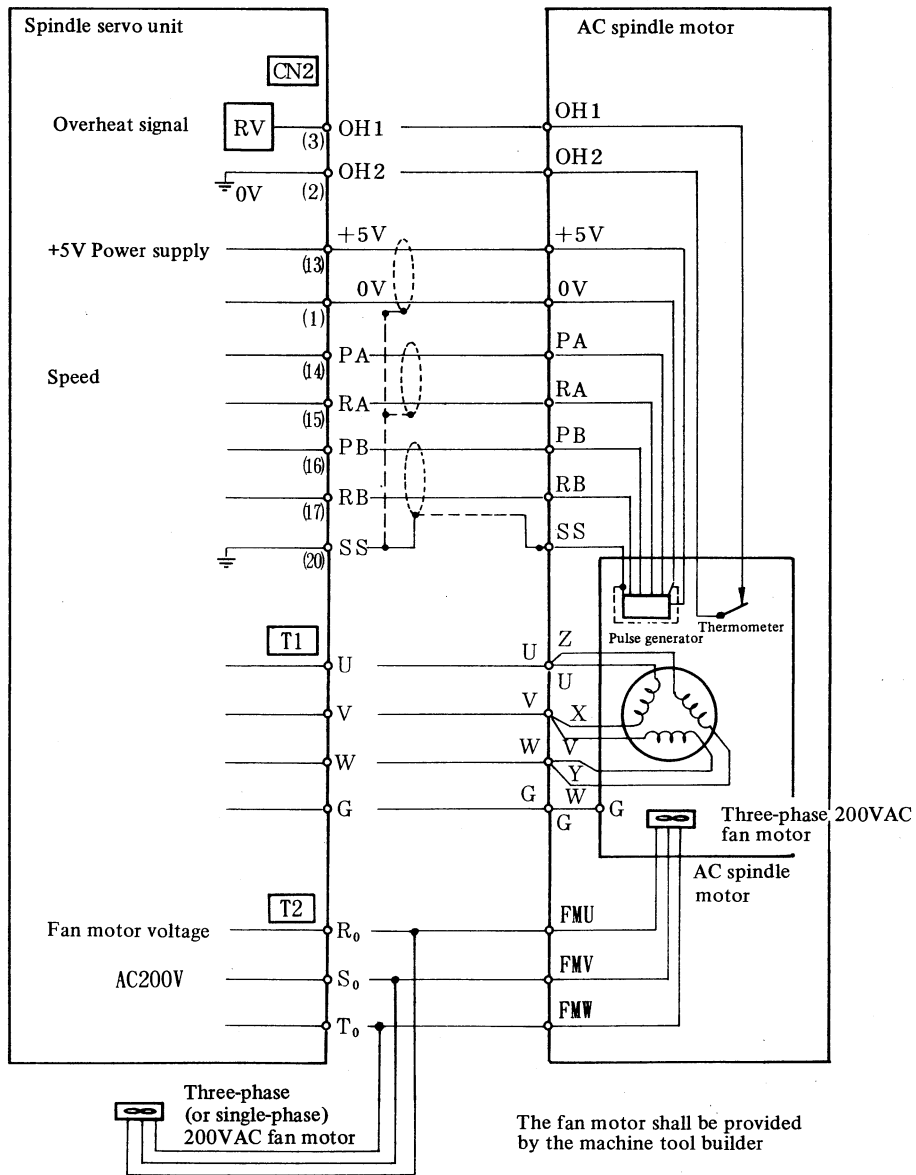

Fan motor is provided by the MTB.

9.3.4 Connecting AC spindle servo unit with unit adapter (Models 6S - 22S)

When wiring the fan motor of the unit adapter, use the terminal block T2 for a fan motor in the AC spindle servo unit. Fuses are included. (See the figure below.)

- (1) AC spindle servo unit and unit adapter (In case of three-phase fan motor, after July, 1990)

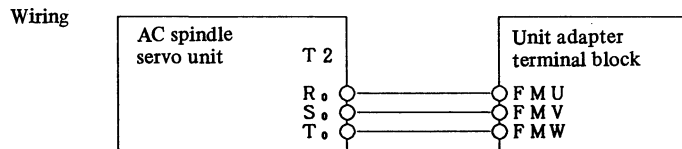
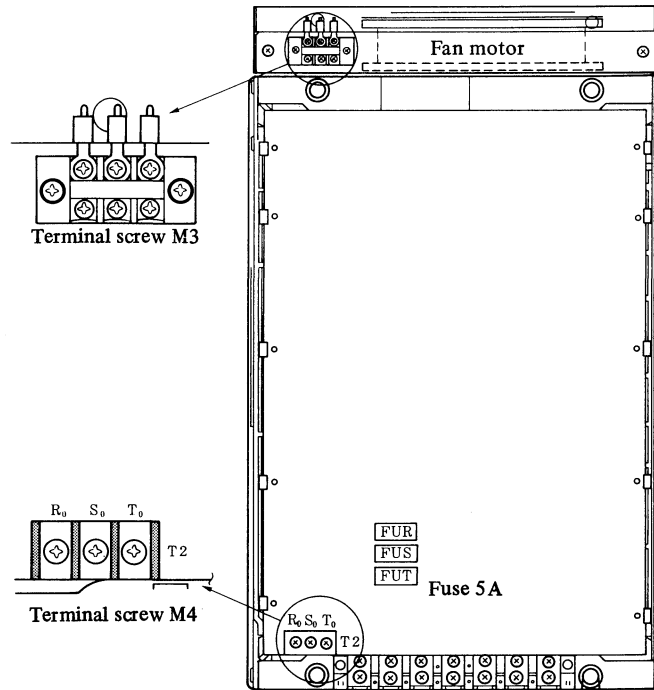

Cable 37/0.26 (2mm²)

(2) AC spindle servo unit and unit adapter (In case of single-phase fan motor, before June, 1990)

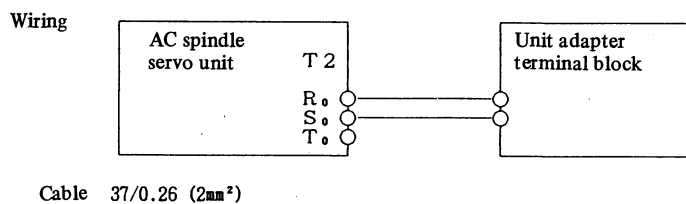
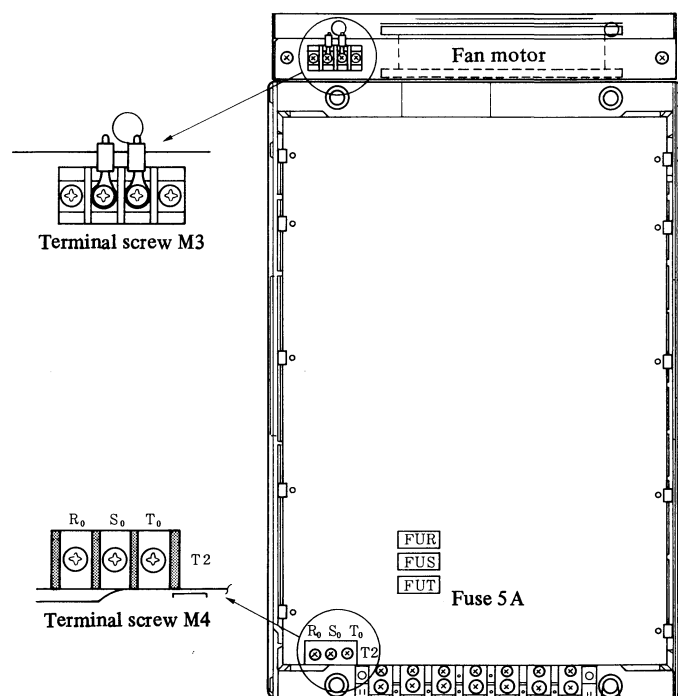

9.3.5 Connection of AC spindle servo unit and resistor unit

(1) A06B-6052-K050

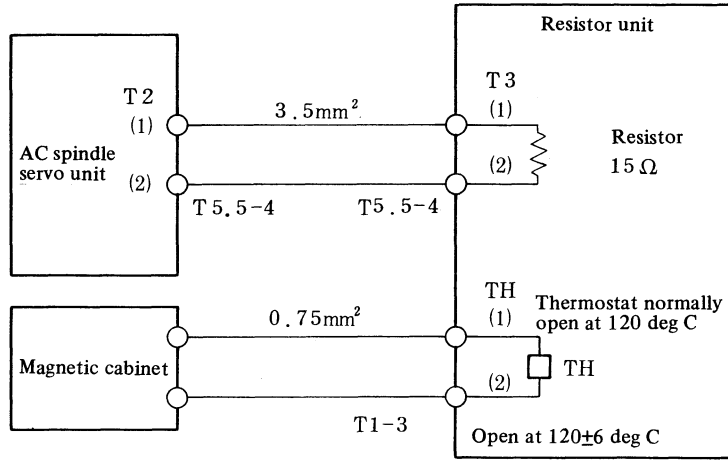

Detects temperature abnormalities
in the resistor unit

(2) A06B-6052-K051

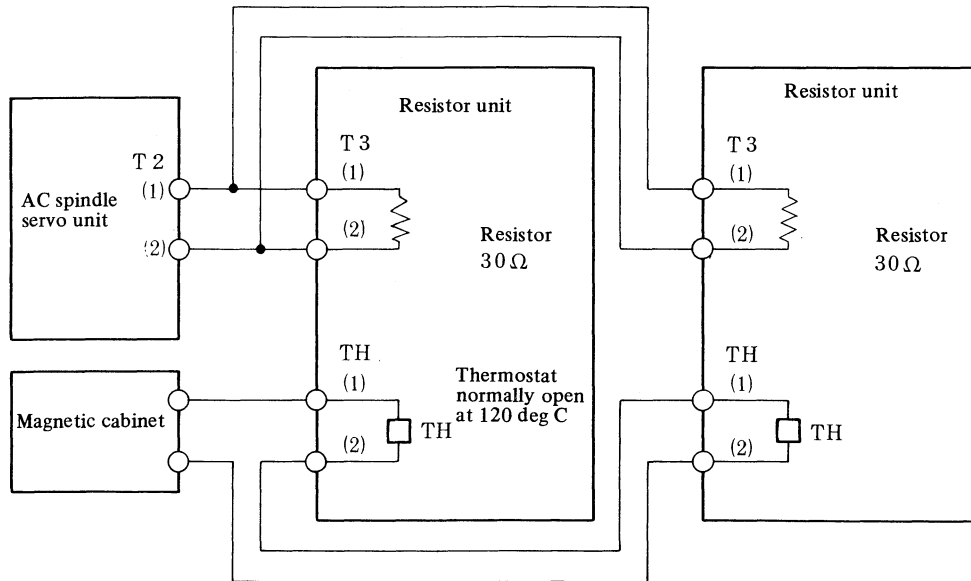

Refer to (1) as for the connecting line, crimp terminal.

(3) 4 resistor units A06B-6052-K050 (15Ω) are used

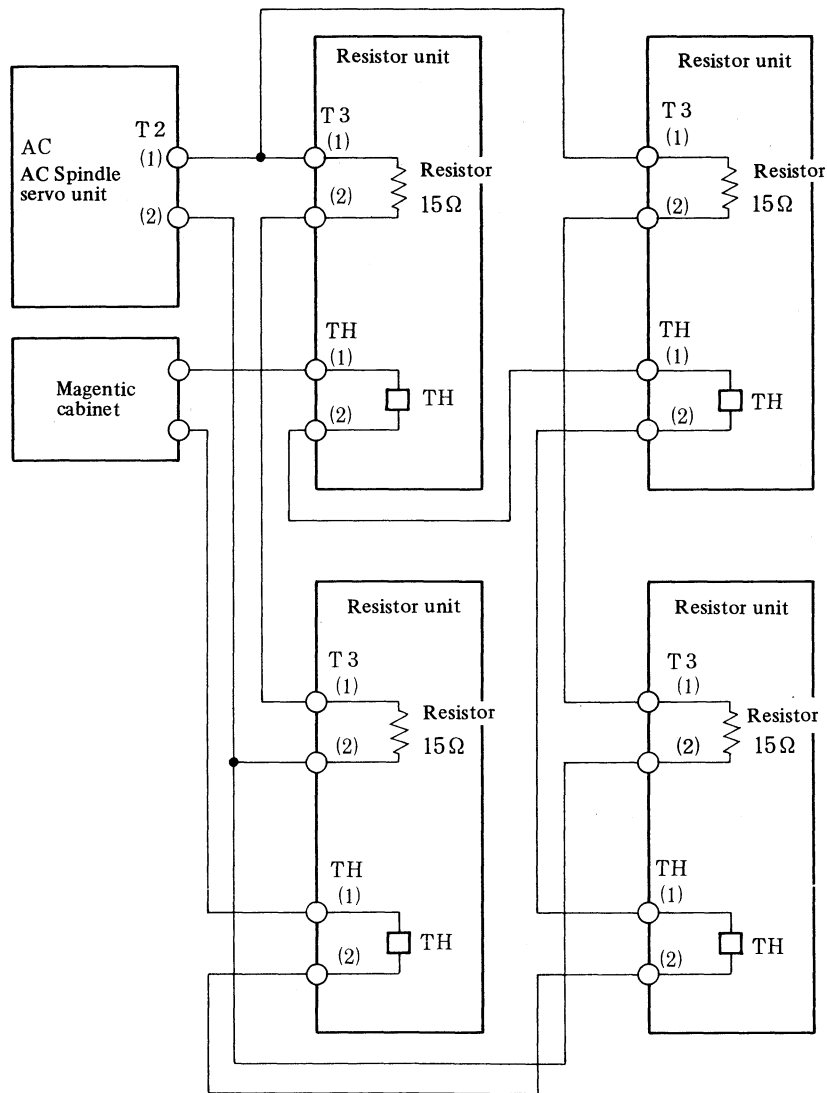

Refer to (1) as for connecting line, crimp terminal.

10. DESCRIPTIONS OF INTERFACE SIGNAL

10.1 Interface Signal Standards

For signals to be transferred between the AC spindle servo unit and the magnetic cabinet, take the following input/output signal rating into due consideration.

1) Contact input signal A

This is inputted from the exterior to the servo unit.

a) External contact capacity required: Higher than 30 V, higher than 16 mA.

b) The following figure indicates the delay time of the receiver output signal to the contact input signal.

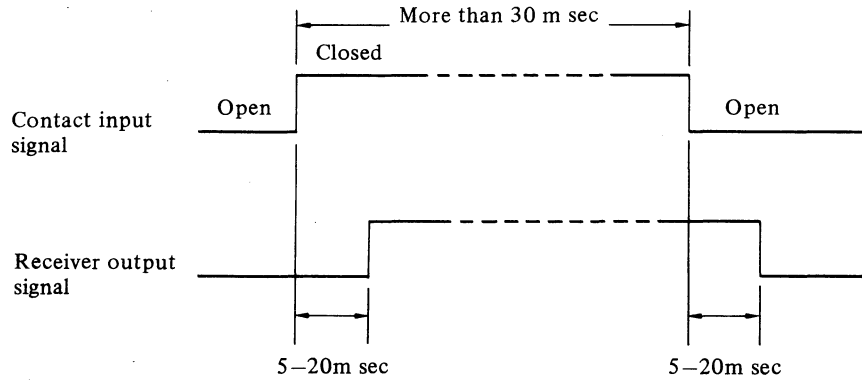

Accordingly, the AC spindle servo unit receives signals after 5 to 20 ms delay when the contact input signal was turned on and off.

c) For the receiver circuit of the AC spindle servo unit, refer to the following figure when using a no-contact input, etc.

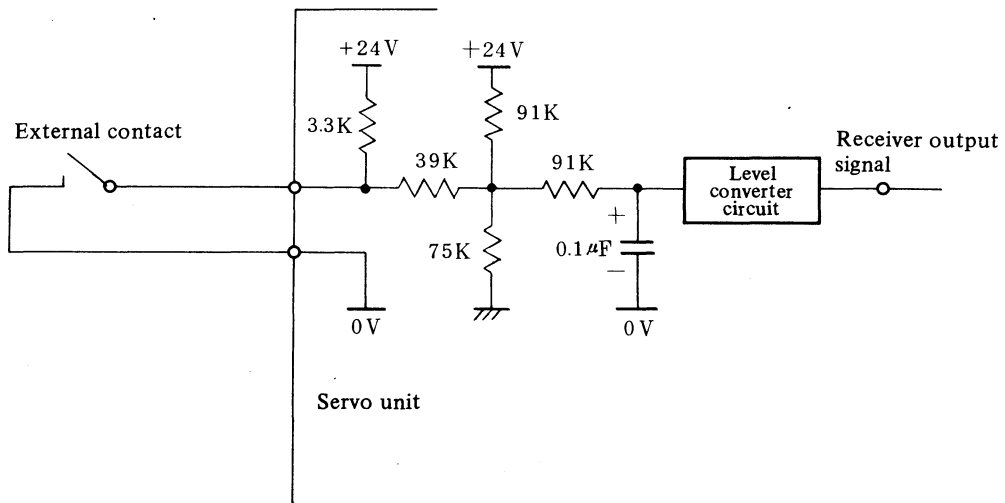

Signification levels in case of no-contact (at input terminal voltage)

Low level logic "0" Lower than 2 V

High level logic "1" Higher than 20 V

2) Contact output signal A1

This is output from the AC spindle servo unit to the exterior.

- a) The AC spindle servo unit side employs a lead relay.

The contact rating is lower than 50 V or lower than 500 mA at 5 VA or lower. Use it at 24 VDC, 200 mA or lower, or 48 VDC, 100 mA or lower, accordingly.

The chattering time of the contact is shorter than 1 m/sec.

The related signals are shown hereunder:

Model	Signal name	Symbol
1S - 3S, 1S/15000, 2S/15000	Orientation completion signal	ORAR1, ORAR2
6S - 22S, 3S/12000 - 22S/6000, 8P - 40P, 8VH, 12VH		

- b) If an external relay or another inductive load is connected, insert a surge absorber in the vicinity of the relay without fail. If a capacitive load is connected, current limiting resistor in series, and set the power to be lower than 5 VA including an instantaneous value.
- c) If an external lamp is connected, insert a protective resistor so that the current becomes lower than 500 mA including an instantaneous value.

3) Contact output signal A2

This is output from the AC spindle servo unit to the exterior.

- a) The AC spindle servo unit side employs a transistor.

The output rating is as follows:

- i. Output voltage maximum 48 V
- ii. Output current maximum 200 mA

The related signals are shown hereunder:

Model	Signal name	Symbol
6S - 22S, 3S/12000 - 22S/6000, 8P - 40P, 8VH, 12VH	Speed arrival signals	SAR1, SAR2
	Zero-speed signals	SST1, SST2
	Speed detecting signals	SDT1, SDT2
	Spindle alarm signals	ALM1, ALM2
	Torque limit signals	TLM5, TLM6
	Load detection signals	LDT1, LDT2

- b) If an external relay or another inductive load is connected, insert a surge absorber in the vicinity of the relay without fail. If a capacitive load is connected, insert a current limiting resistor in series, and set the power to be within the output rating including an instantaneous value.
- c) If an external lamp is connected, insert a protective resistor so that the current becomes within the rated output current including an instantaneous value.

4) Contact output signal A3

This is output from the AC spindle servo unit to the exterior.

a) This is output by an open collector (polarized) from the AC spindle servo unit.

The output rating is as follows:

- i. Rated voltage: less than 30 VDC
- ii. Output current: less than 40 mADC
- iii. Saturated voltage: 1.5 or less (IC = 40 mA)

b) Signal polarity is as follows:

Model	Signal name	Polarity	
		Positive (+)	Negative (-)
1S - 3S	Speed arrival signals	SAR1	SAR2
	Zero-speed signals	SST1	SST2
	Speed detecting signals	SDT1	SDT2
	Spindle alarm signals	ALM1	ALM2
	Torque limit signals	TLM5	TLM6
	Load detecting signals	LDT1	LDT2
6S - 22S	Alarm content signals	AL1 AL2 AL4 AL8	COM

10.2 Spindle Control Signals

Refer to 10.1 "Interface Signal Standards" for standards of the signals.

10.2.1 Emergency stop signal (ESP1, 2)

- 1) When the contact is ON (closed), the spindle motor and the servo unit is ready for operation. When the contact is off (open), the magnetic contactor in the servo unit is OFF, and the spindle motor does not operate.
- 2) When the contact becomes OFF (open) during rotation of the motor, the spindle motor will decelerate and stop at once. The magnetic contactor will also become OFF after the motor stops.
- 3) When this contact is turned on (closed) again, the spindle motor is placed to be ready for rotation. It rotates immediately when the rotation command is given. Accordingly, reset the command signals (velocity command, forward rotation, reverse rotation commands) to the spindle servo unit simultaneously when the emergency stop signal was inputted.

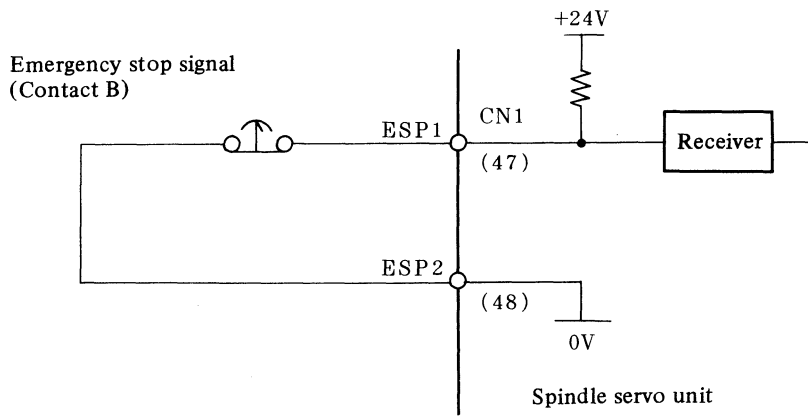

10.2.2 Machine ready signal (MRDY1, 2)

1) Mode set by parameters F-01 and F-09 is shown below.

Mode	Setting		Contents
	F-01	F-09	
(A)	0	0 or 1	Machine ready signal is not used. Input of the emergency stop signal alone will make the spindle motor ready for operation.
(B)	1	0	Machine ready signal is used to make an operation ready status by double signal. When the contact is off the electro-magnetic contactor will come OFF to cut off the motor power.
(C)	1	1	Power is cut off by cutting the excitation signal of the transistor in inverter section when the contact is OFF the electro-magnetic contactor is still ON.

Note) Contact: Contact of MRDY signal.

The following 2) to 4) are how to use the machine ready signals in each of the above modes.

2) Mode (A)

Used to minimize the input signal points. It is not necessary to connect the signal line to the contact.

3) Mode (B) (Standard setting)

- ① Used to control an operation ready status by double signal. For example, when it is necessary to set two electro-magnetic contactor ON/OFF signal input terminals on machines where the worker must touch the spindle directly for loading and unloading workpieces or tools.
- ② When the contact is ON (closed), the electro-magnetic contactor turns ON, and the motor becomes ready for operation.
- ③ When the contact is OFF (open), the electro-magnetic contactor turns OFF, and the power to the motor is cut off.
- ④ If the contact is turned OFF (open) during the rotation of the motor, the spindle motor will decelerate to a stop at once, and the electro-magnetic contactor will also turn OFF after the motor stops.

- ⑤ Do not use the electro-magnetic contactor too frequently (some 100 times) in a single day, because it may shorten the electro-magnetic contactor's open/close life.
- 4) Mode (C)
- 1 Used in case the open/close of the electro-magnetic contactor is assumed to be frequent.
 - ② In machines in which a spindle motor is restricted by the tool unclamp signal during operation of the automatic tool change (ATC) orientation, the command of the load meter may become large or large motor current may flow because of a small shift from the orientation stop position. In this case, cancel an orientation status during tool unclamp by making OFF this signal. Orientation status can be made by making ON this signal without spindle rotation at tool unclamp ending.
 - ③ If the contact of the orientation command signal is still ON (closed) in the above ②, the OFF/OFF of the contact of the machine ready signal will only cause a small shift of the stop position; it is not necessary to perform orientation again with another rotation.

Timing chart

Condition) Parameter F-01:1 Use machine ready signal.

Parameter F-09:1 Cut the motor power using MRDY signal.

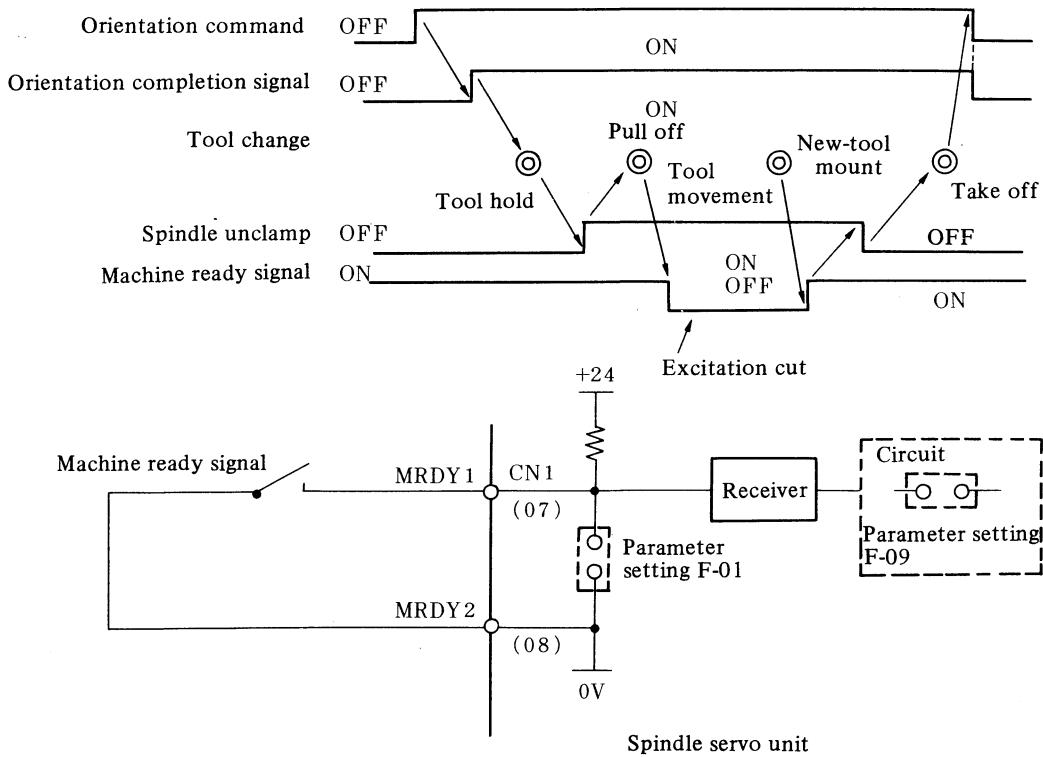

10.2.3 Forward rotation command signal (SFR)

- 1) The AC spindle motor will start forward rotation according to the velocity command (positive voltage) when the following three conditions are satisfied.
 - ① The contact of emergency stop signal is ON (closed)
 - ② The contact of machine ready signal is ON (closed)
 - ③ The contact of forward rotation command signal is ON (closed)
- 2) During contact on (closed), the AC spindle motor rotates counterclockwise (CCW) as viewed from the shaft side according to the command speed.

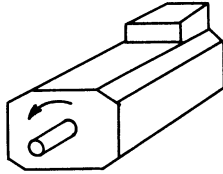

- 3) When the contact turns off (open), the AC spindle motor is stopped by the regenerative braking. After stopping, the base signal of the transistor is turned off to interrupt the power to the AC spindle motor.

10.2.4 Reverse rotation command signal (SRV)

- 1) The AC spindle motor will start reverse rotation according to the velocity command (positive voltage) when the following three conditions are satisfied.
 - ① The contact of emergency stop signal is ON (closed)
 - ② The contact of machine ready signal is ON (closed)
 - ③ The contact of reverse rotation command signal is ON (closed)
- 2) During contact on (closed), the AC spindle motor turns clockwise as viewed from the shaft side according to the command speed.

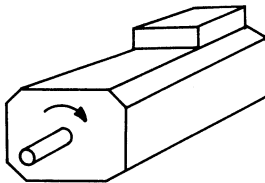

- 3) When the contact turns off (open), the AC spindle motor is stopped by the regenerative braking. After stop, the base signal of the transistor is turned off to interrupt the power to the AC spindle motor.
- 4) When the forward rotation command signal and reverse rotation command signal are turned on simultaneously, the spindle motor stops.

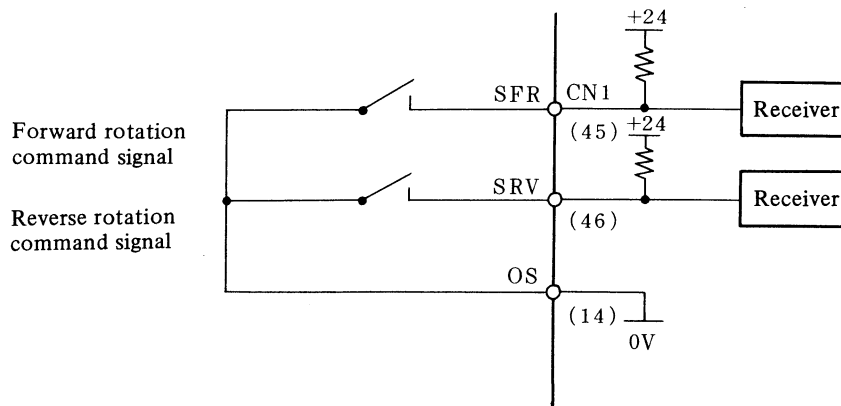

10.2.5 Analog voltage signal (DA2, E)

- 1) The speed command voltage and the AC spindle motor speed are in linear proportion as shown in the following figure.

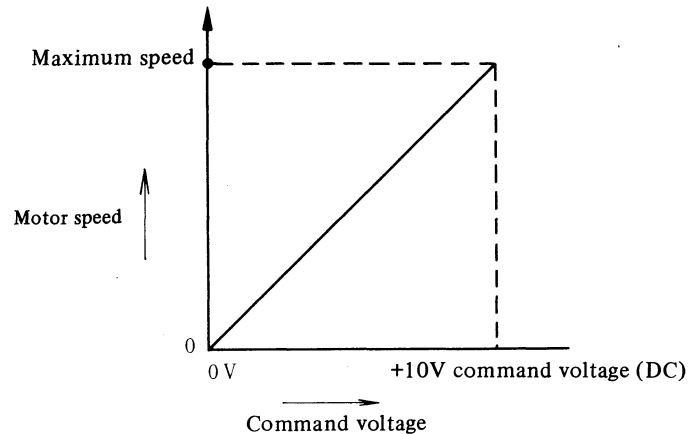

- 2) Normally, command the positive voltage (0 to +10.0 VDC). Use the forward/reverse rotation command signals to distinguish the direction of rotation.
- 3) The positive/negative command voltages (0 to ± 10 VDC) result in the following figure.

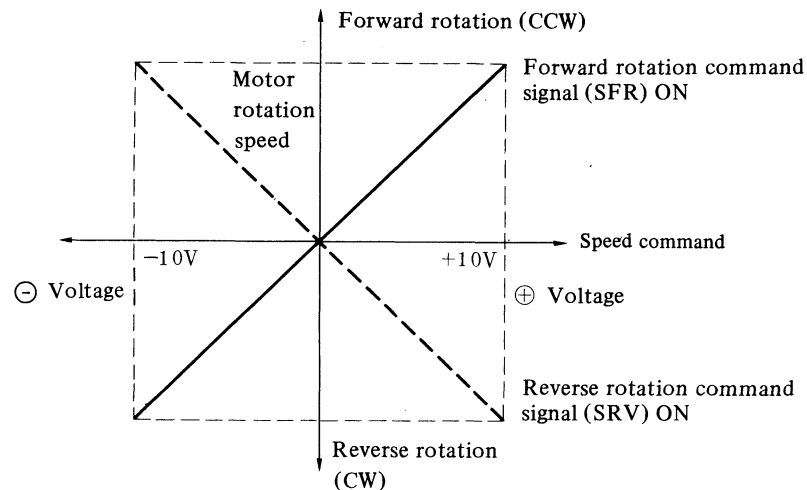

Do not command the positive/negative voltages to the machine whose tool and workpiece may break or in which the safety cannot be guaranteed when rotated in the reverse direction by a forward command.

- 4) Be careful with wiring so that the velocity command voltage line is not affected by external noises. Use a shielded wire without fail.
- 5) Compose the speed command voltage (0 to +10 VDC) circuit as shown in the figure below. In this circuit, the manual input (analog input) and automatic command (DA converted output) are selectable by relay. If the speed command voltage exceeds +10 V, it is automatically clamped to max. 10.7 V internally. Be careful since the motor revolution reaches max. 107% of the rated value.
- 6) The motor is not rotated when only the speed command voltage is applied. It rotates when either a forward or reverse rotation command was given.
- 7) When the speed command voltage became ± 10 V or more, it will automatically be internally clamped to maximum ± 10.7 V. However, pay attention as the motor speed may rise to a maximum 107% of the rated rotation.

- 8) The movement of the motor will differ according to the ways the speed command voltage and the forward/reverse rotation command signals (SFR/SRV) are given. Change the speed command voltage inputs as the following figure, and then set the forward/reverse rotation command signals ON (closed).

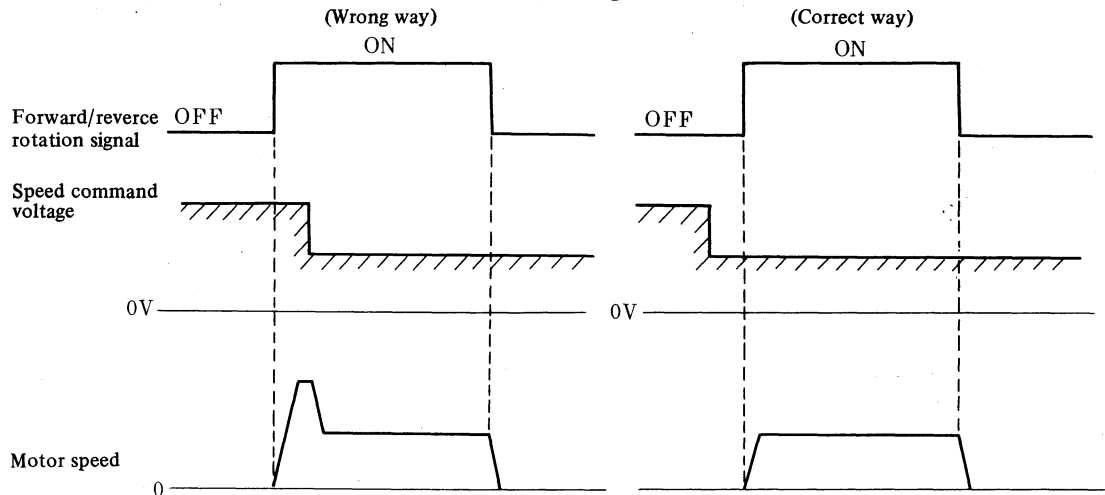

- 9) Example of connection when using the analog output of the CNC.

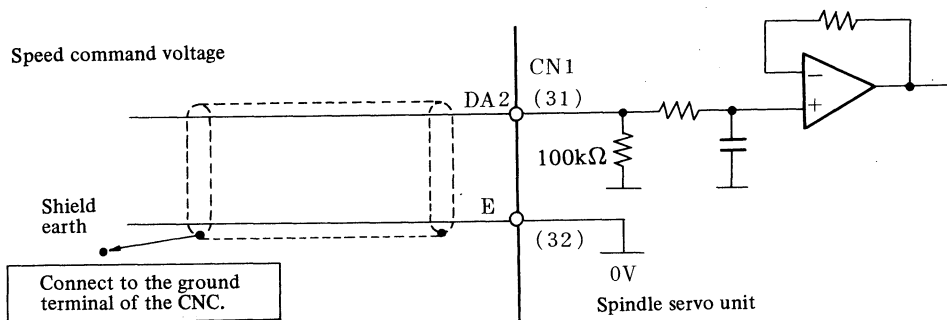

- 10) The input impedance of the speed command voltage receiver circuit of spindle servo unit is 100 kΩ.

10.2.6 +15V power (+15V, E)

- 1) This power supply is used to give analog speed command using the variable register, from outside the unit in manual input.
- 2) Maximum 30 mA current can be used in this +15 V power source.

10.2.7 Spindle rotation speed override (OVR1, OVR2)

- 1) Unusable with models 6S - 22S (Models 1S - 3S are not provided with this function)
- 2) This signal is used to override the spindle speed of the automatic speed command, to gain the optimum cutting condition. The NC system also has the spindle speed override function. Use the function of the NC system normally.
- 3) When using the speed override function of the AC spindle servo unit, establish the circuit as shown in the figure hereunder externally.

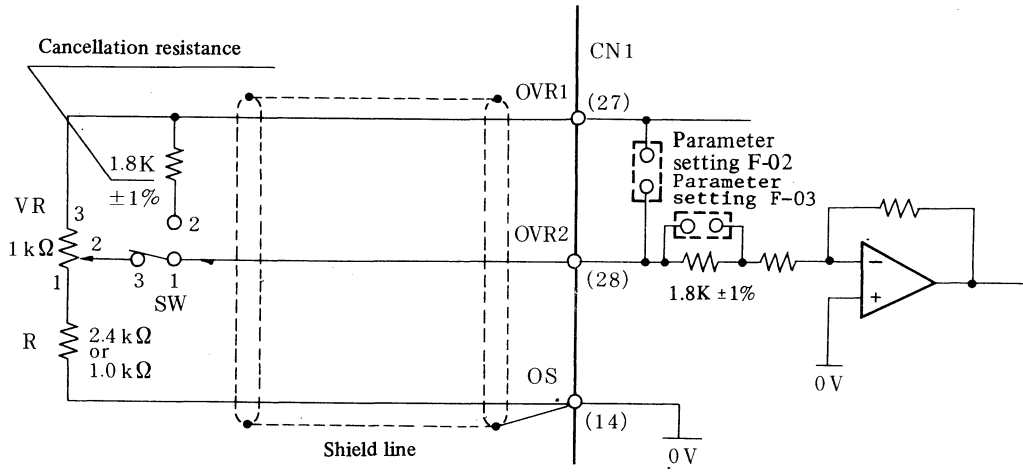

Override cancel (Short SW1-2)
Speed override (Short SW1-3)

AC Spindle servo unit

- 4) When performing synchronous feed as thread cutting or other external manual velocity commands, the override must be cancelled. Switch the circuit (short SW1-2) and set the override precisely to 100%.
- 5) Setting on the AC spindle servo unit for speed override function and the range of override is as follows.

Function	Parameter	
	F-02	F-03
Speed override function not used	0	0
Speed override function used	Override range Up to 120% (upper limit)	1
	Up to 100% (upper limit)	0

- 6) The override range is determined by the resistance value of R in the figure.
When R = 1.0 kΩ: 60 to 120%
R = 2.4 kΩ: 80 to 120%

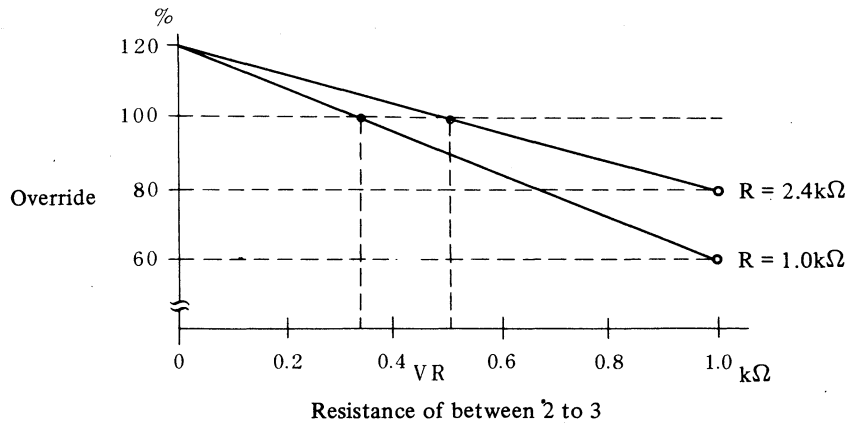

- 7) If the override range upper limit is set to 100%, short cancel resistor 1.8 k Ω , since this resistor is not needed.

10.2.8 Torque limit command signals (TLM1, TLML, TLMH, OT)

(Models 1S - 3S, TLM1, OT: Models 6S - 22S., TLMH, TLML, .OT)

- 1) The torque limit is used to temporarily reduce the output torque of the AC spindle motor during the AC spindle motor rotation in case of mechanical spindle orientation, gear shift, etc.
- 2) The machine tool builder is requested to set the orientation output torque and the revolution at the orientation time for every model so as to reduce a shock when the machine stopper operates.
- 3) Adjust the torque at the time of torque limit by parameter F-18.
The torque limit value is \pm (set value of F-18)% of the maximum torque when TLMH is ON. When TLML is ON (TLM1 is ON as for the models 1S - 3S), the torque is about 1/2 of the TLMH:ON.
- 4) When the torque limit command signal turns on (closed), the torque is limited. (This signal is effective at once, even if this torque limit command is given during the motor rotation.) The torque limiting signals (TLM5, TLM6) are sent outside, immediately when the torque is limited.
- 5) For executing the mechanical orientation during ATC of a machining center, take the following items into consideration when designing the power magnetic sequence so as not to damage the stopper.
 - (1) The output torque is suppressed during orientation so as not to allow it to be excessively large.
 - (2) The revolution is suppressed during orientation so as not to allow it to be excessively high. If an excessively high revolution is detected by the speed detection signal, take the interlock not to operate the stopper.
 - (3) The stopper should be securely retreated when the torque limit was released.

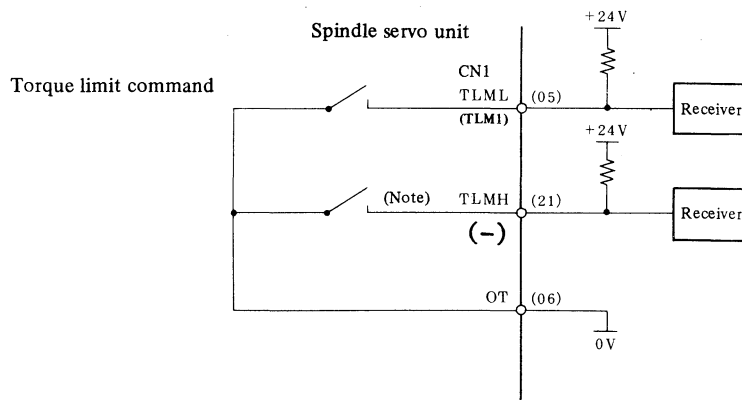

(-) is for models 1S - 3S.

Example of mechanical orientation sequence

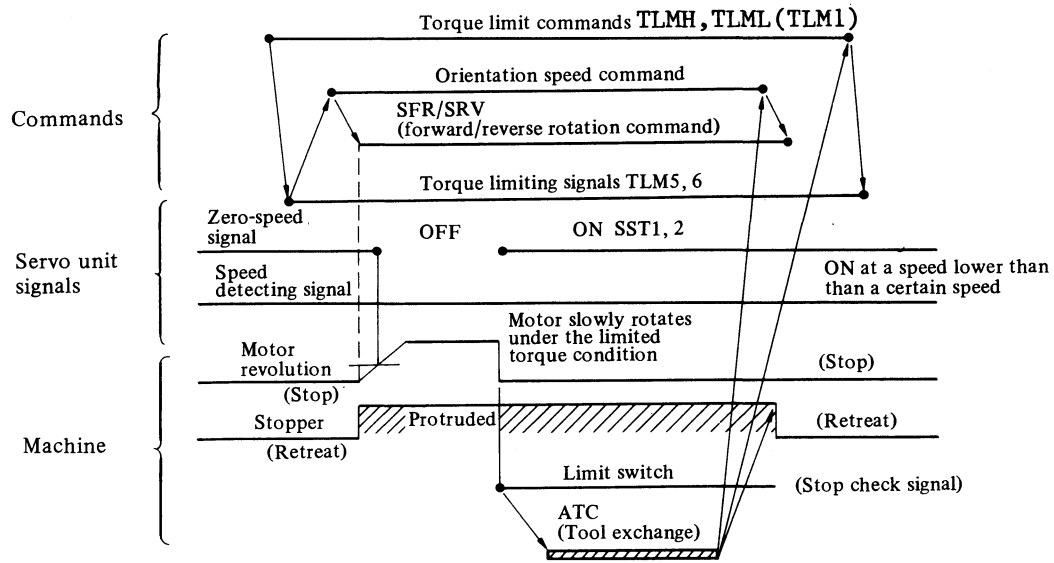

If the above conditions are difficult, adopt the electric spindle orientation (option) without stopper.

10.2.9 Alarm reset signals (ARST1, 2)

- 1) After eliminating causes of alarms such as motor overheat, excessive speed deviation, circuit short-circuit, overspeed, overvoltage, overcurrent, overload, power drop, etc., then input the alarm reset signal, and the alarm is released to place the unit in readiness for operation.
- 2) This signal is ineffective, if it is inputted during the absence of alarm.
- 3) The servo unit is also provided with a reset switch, which has the same function as this alarm reset signal.

10.3 Orientation Signal (ORCM1, 2)

Connected when using the spindle orientation control circuit (option). Description of the signal is mentioned in Chapter IV.

10.4 Spindle Control Output Signals

For the output signal rating, refer to section 10.1.

10.4.1 Speed arrival signals (SAR1, 2)

- 1) The contact is turned on (closed) when the actual rotation speed of the spindle motor reaches a certain preset range with reference to the command speed.

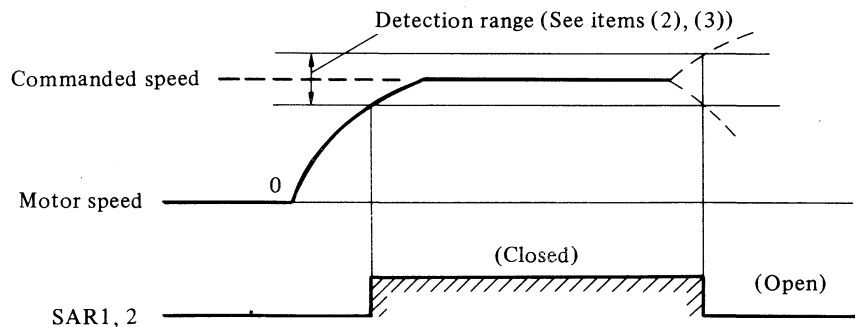

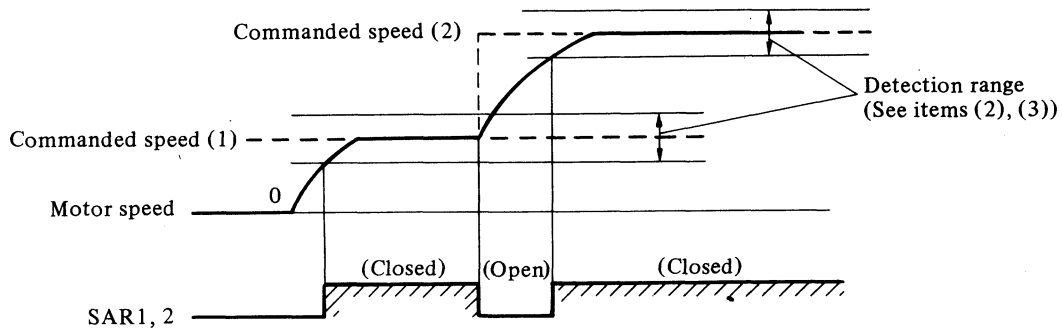

- 2) The preset range is adjustable within a range of ± 1 to 100% of the command speed; provided that the detection range becomes wider than the preset range, if the speed is lower than 10% of the maximum speed.
- 3) This detection range of the speed arrival signals is set to $\pm 15\%$ as the standard setting before shipment. However, it is expanded as illustrated below at low speed.

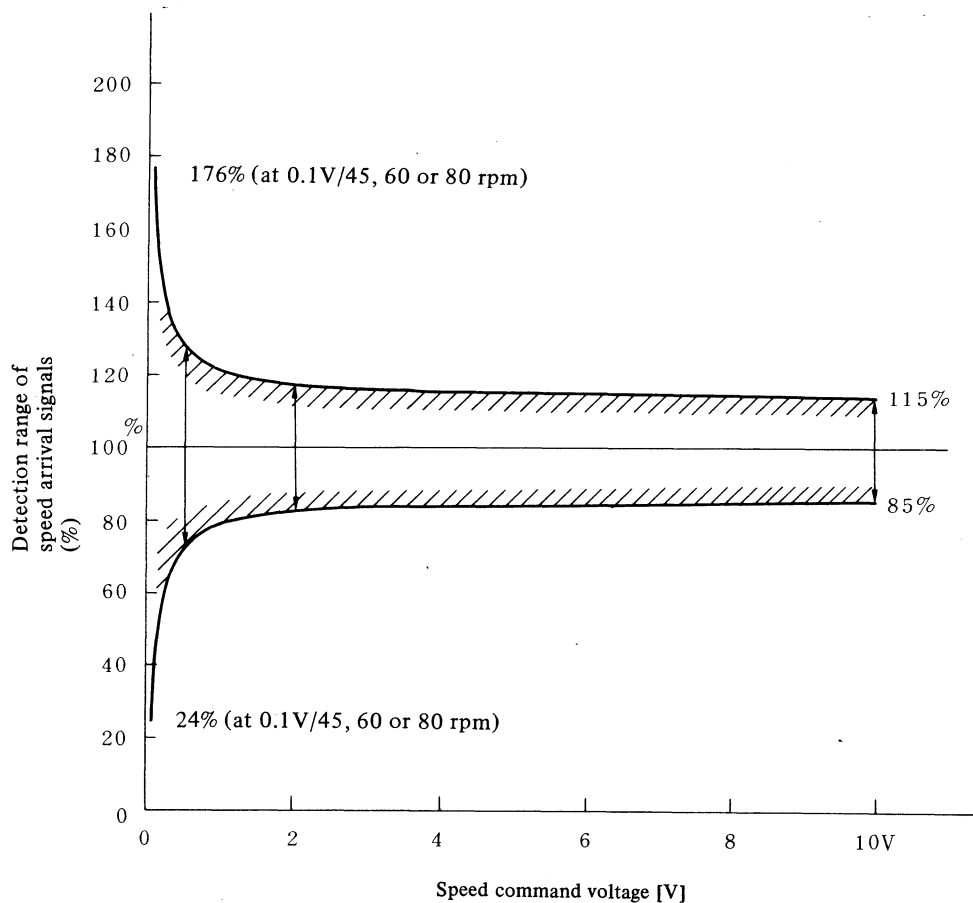

0	1,600	3,200	4,800	6,400	8,000 rpm
0	1,200	2,400	3,600	4,800	6,000 rpm
0	900	1,800	2,700	3,600	4,500 rpm

Speed [rpm]

If a 45/60/80 rpm of speed command is issued, the arrival signal is sent when actual motor speed reaches 45/60/80 rpm $\pm 7\%$.

- 4) This signal is not outputted, unless either SFR or SRV is turned on.
- 5) The reverse rotation at the tapping cycle is controlled by using this signal as follows.

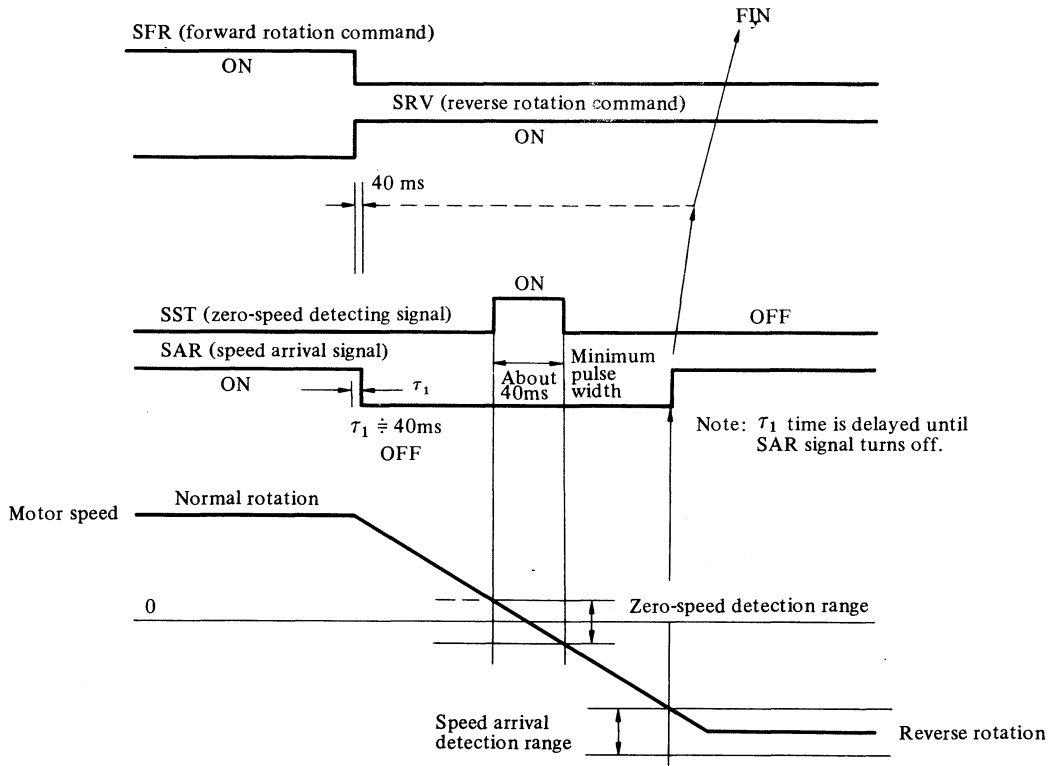

When the reverse rotation command is sent, the spindle motor starts deceleration, and the speed arrival signal turns off within 40 ms. Then, the next turn-on of the speed arrival signal is detected as the reverse rotation command end.

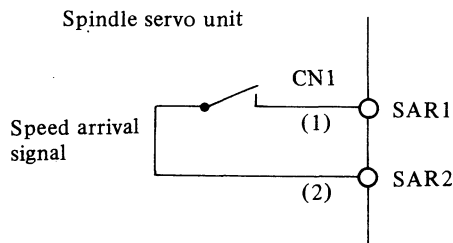

Note) Models 1S - 3S are output by an open collector transistor (polarized).

- 6) This signal is employed as the check signal (FIN signal) for forward rotation (M03) and reverse rotation (M04) command.

10.4.2 Zero-speed detecting signals (SST1, 2)

- 1) If actual rotation speed of the spindle motor is reduced to be lower than the zero-speed detection point when the stop command was given, the contact is turned on (closed).

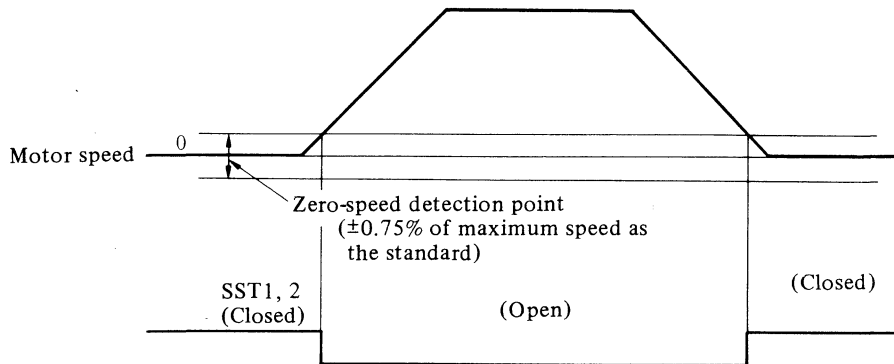

- 2) The zero-speed detection point is fixed at 0.75% of the maximum speed as the standard.
In other words, the zero-speed detection signal turns on when the rotation speed is lower than about 33, 45 or 60 rpm.
- 3) This signal is outputted when the above condition is satisfied, irrespective of rotation commands (SFR, SRV).
- 4) The minimum pulse width value of this signal is about 40 ms. Refer to section 9.4.1-(5).

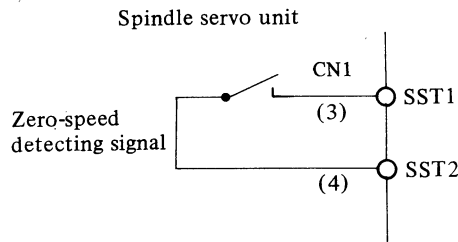

Note) Models 1S - 3S are output by an open collector transistor (polarized).

10.4.3 Speed detecting signals (SDT1, 2)

- 1) The contact is turned on (closed) when the actual motor speed is lower than the speed being set on Parameter F-17.
- 2) The detection point is fixed at the maximum speed x (set volume of F-17/1000)%.

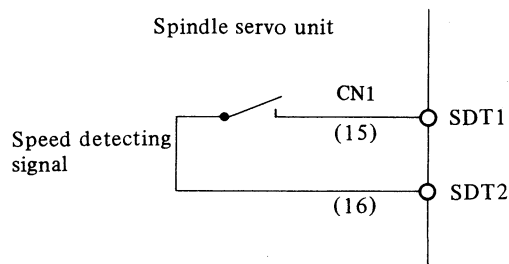

Note) Models 1S - 3S are output by an open collector transistor (polarized).

- 3) This signal is used to detect the rotation speed which becomes lower than a certain speed set such as clutch selectable speed or gear selectable speed. It is usually set to 3% of the maximum speed (standard setting) in case of gear change or 30% of the maximum speed in case of clutch change. The machine tool builder is requested to set the check terminal voltage to a desired value by the variable resistor.

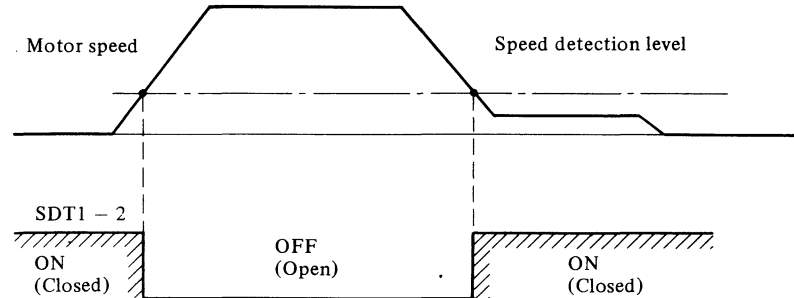

- 4) The signal contact is turned on (closed) when the absolute value of the motor speed is reduced to be lower than the preset detection level, irrespective of rotation commands (SFR, SRV).

(Reference)

Sequence of the gear shift

The gear shift in the CNC machine tool is one of sequence controls. The electric circuit signal on the sequence is used to move the spindle gear, which is an important component of the machine. It is then necessary to check that the spindle motor revolution is in low speed to switch the gear safely.

The following is an example of sequence at gear shift, when the speed detection signal (gear selectable signal) was used. This example can be referred to when designing the magnetics sequencer.

An example of gear shift sequence using speed detection signal

(Sequence)

(Check signal)

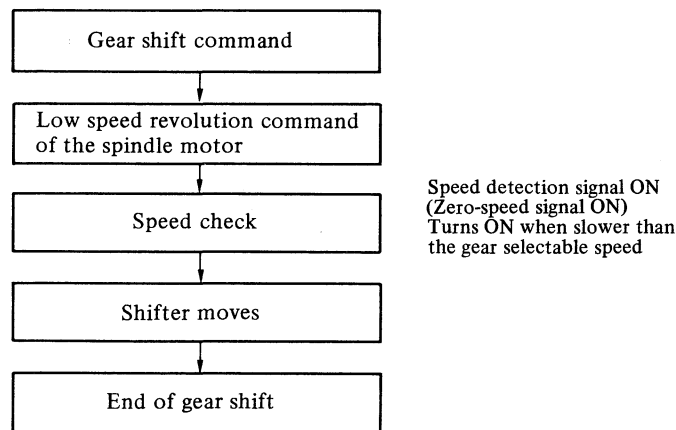

To change the gear safely, check that the spindle motor revolution is low enough before moving the shifter. If the zero-speed signal is also applied, the safety can be doubly checked.

If the shifter moves when the spindle motor is rotating in high speed, the gear will break.

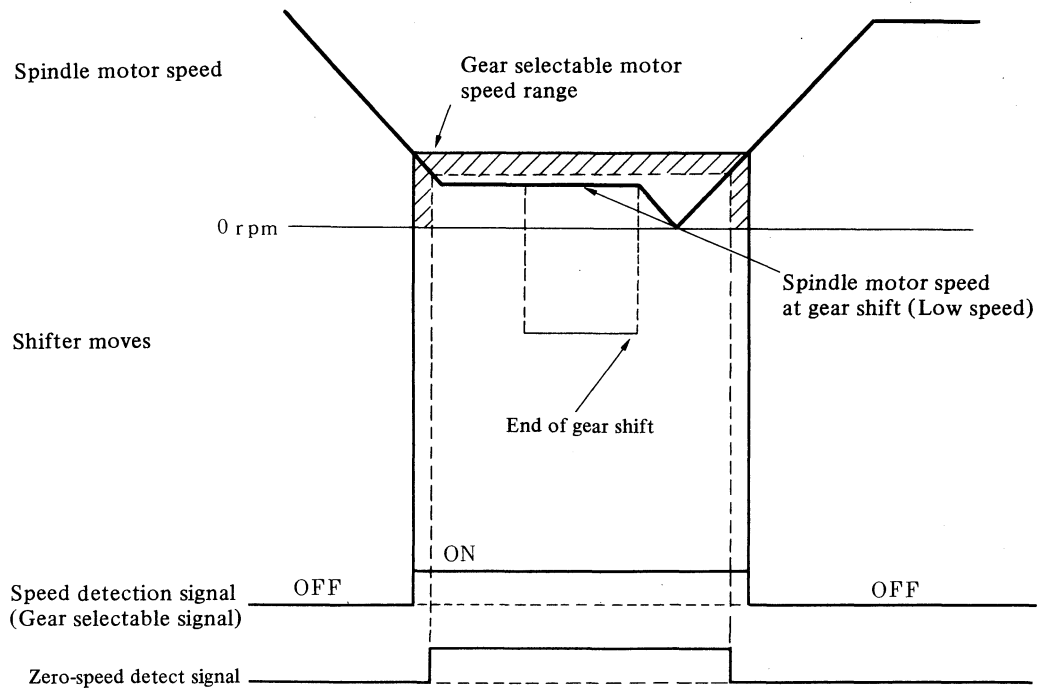

10.4.4 Load detection signal (LDT1, 2)

When the load becomes greater than the set value (%) against the maximum detection level (10 V) of the load meter, the contact is ON (closed).

Note) For models 1S - 3S

LDT1 CN1 (33)

LDT2 CN1 (34)

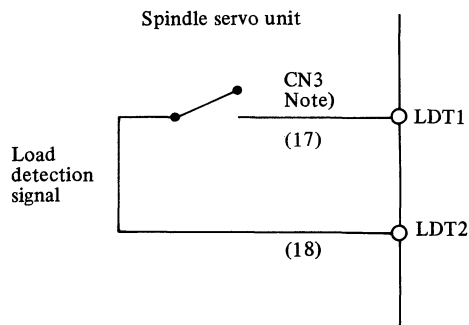

. Output by an open collector transistor (polarized).

10.4.5 Spindle alarm signals (ALM1, 2)

- 1) If the spindle motor operation cannot be continued due to trouble, the spindle motor power is turned off to stop the spindle motor. An alarm signal is also sent to the exterior concurrently. (The output contact is open under an alarm condition.)
- 2) The alarm signals employ one contact only. For the alarm contents, refer to section 10.5 alarm contents signal.
- 3) Reset the command signals (speed command, forward rotation, reverse rotation commands, and torque limit command) to the spindle servo unit by using this alarm signal output without fail (clear all signals from PMC). Otherwise the spindle motor may rotate when the alarm of the spindle amplifier was released, and a dangerous accident may result.

- 4) Since the spindle motor is decelerated and stopped simultaneously when an alarm signal is outputted, it is necessary to set the emergency stop condition or feed hold condition on CNC or the power magnetics control panel side.
- 5) The contact is open under an alarm condition.
The spindle motor is being decelerated and stopped during alarm signal off (open contact), irrespective of external commands.
- 6) The relation between alarm signals and alarm reset signal is as illustrated below.

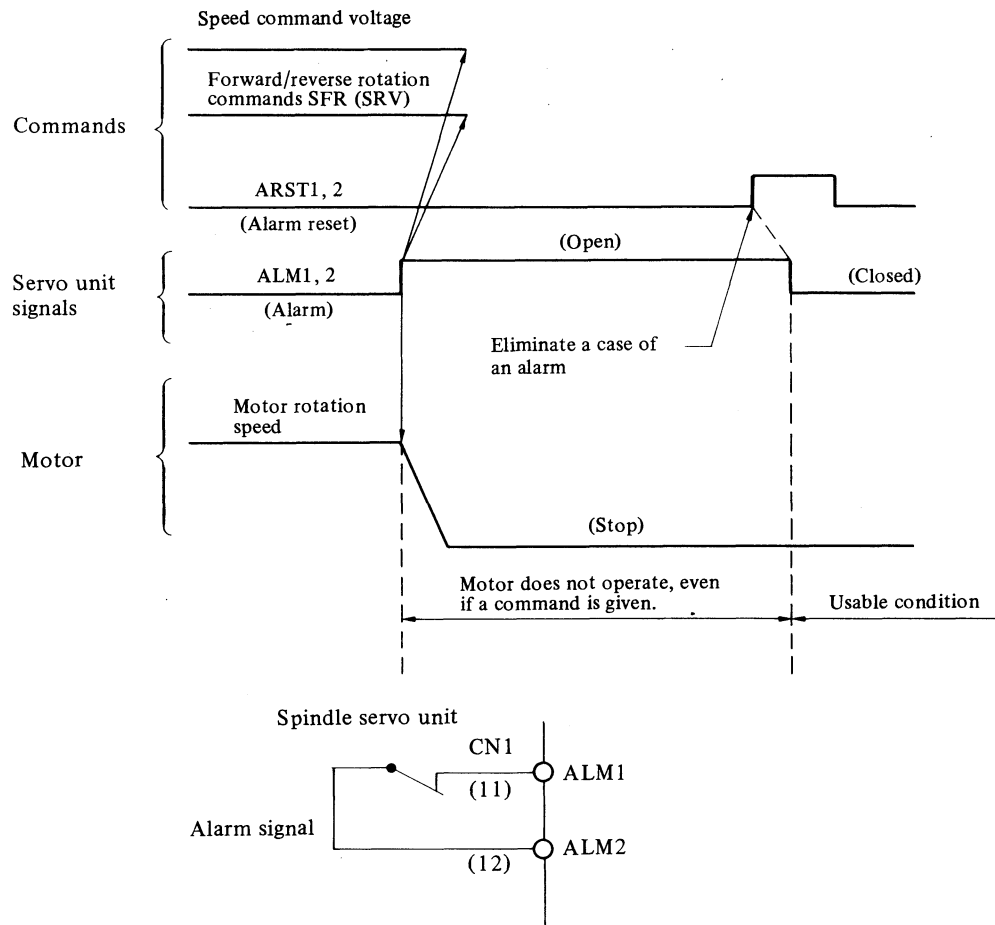

Note) Models 1S - 3S is output by an open collection transistor (polarized)

10.5 Alarm Content Signals (AL8, AL4, AL2, AL1)

- 1) These signals are provided with models 6S - 22S. (Models 1S - 3S are not provided with these signals)
- 2) The alarm conditions of the AC spindle motor and AC spindle servo unit are indicated by light-emitting diodes on PCB of the AC spindle servo unit. Alarm contents are sent to the exterior by code signals concurrently.

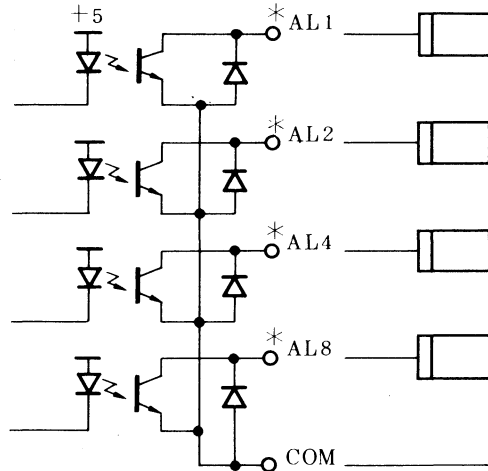

- 3) The correspondence between LED display and alarm signals is as shown in the following table.

LED display	Alarm content signals			
	AL8	AL4	AL2	AL1
AL-01				o
AL-02			o	
AL-03			o	o
AL-04		o		
AL-05		o		o
AL-06		o	o	
AL-07		o	o	o
AL-08	o			
AL-09	o			o
AL-10	o		o	
AL-11	o		o	o
AL-12	o	o		
AL-13	o	o		o
AL-14	o	o	o	
AL-15	o	o	o	o

o: Contact ON (closed)

- 4) Alarm signals can be received at magnetics sequencer and their signals can be displayed on the CRT of CNC. These signals can be used to design magnetics sequence by the MTB.
Alarm contents are shown in the Table 10.5 (a) (Models 1S - 3S) and Table 10.5 (b) (Models 6S - 22S).

Table 10.5 (a) Alarm (Models 1S - 3S, 1S/15000, 2S/15000)

Alarm No.	Meanings	Contents
AL-01	Motor and radiator overheat	This lamp lights when internal temperature of motor and radiator of the units is higher than the specified value.
AL-02	Excessive deviation of speed	This lamp lights when the motor speed is largely deviated from the command speed.
AL-03	Defective regenerative current	Detects that regenerative current has flown longer than the allowable time
AL-04	—————	
AL-05	—————	
AL-06	Overspeed (Analog detection)	This lamp lights when the motor exceeds 115% of the rated speed.
AL-07	Overspeed (Digital detection)	This lamp lights when the motor exceeds 115% of the rated speed.
AL-08	Overvoltage	This lamp lights when voltage largely exceeds the rated working voltage range due to a tap selection failure, etc.
AL-09	—————	
AL-10	Detects lower voltage	Detects the input power voltage lessened.
AL-11	Excessive high voltage of DC link	Detects over DC voltage of power.
AL-12	Abnormal current of DC link Defective transistor	Detects over current of circuit.
AL-13 - 15	—————	
AL-16 - 23	Defective arithmetic circuit and peripheral circuit.	
No display	Defective ROM.	

Table 10.5 (b) Alarm (Models 6S - 22S, 3S/12000 - 22S/6000, 8P - 40P, 8VH, 12VH)

Alarm No.	Meanings	Contents
AL-01	Motor overheat	This lamp lights when internal temperature of motor is higher than the specified value.
AL-02	Excessive deviation of speed	This lamp lights when the motor speed is largely deviated from the command speed.
AL-03	+24 V fuse is blown. PCB with version No. of 09A or earlier	+24 V fuse of the control power section is blown.
	PCB with version No. of 10B or earlier	No AL-03 on the PCB version 10B or later.
AL-04	Open phase of input power	A phase of input power is open.
AL-05		—————
AL-06	Overspeed (Analog detection)	This lamp lights when the motor exceeds 115% of the rated speed.
AL-07	Overspeed (Digital detection)	This lamp lights when the motor exceeds 115% the of rated speed.
AL-08	Overvoltage	Voltage extremely excesses the rated voltage.
AL-09	Overheat of radiator	Temperature of radiator such as semiconductor is extremely high.
AL-10	Lower voltage of input power	Detects lower voltage of input power.
AL-11	Excessive high voltage of DC link	Detects over DC voltage of power.
AL-12	Abnormal current of DC link Defective transistor	Detects over current of circuit.
AL-13	Defective arithmetic circuit	Abnormal transmission between microcomputer and peripherals.
AL-14	Defective ROM	Detects defective ROM.

Table 10.5 (c) Alarm (Models 6S - 22S, 3S/12000 - 22S/6000, 8P - 40P, 8VH, 12VH)

Alarm No.	Meanings	Contents
AL-15	Defective optional circuit	Detects defective optional circuit and erroneous connection to optional circuit.
A-16 - 23	Defective peripheral of arithmetic circuit and circuit.	
A	Defective ROM.	

10.6 Speed Indication Voltage Signal (SM1, OM)

- 1) The rotation speed of the AC spindle motor can be indicated by externally connecting a speedmeter.

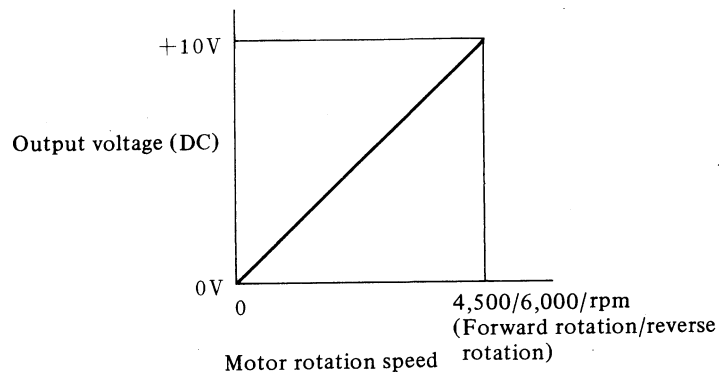

A voltage (DC) proportional to the rotation speed is outputted, irrespective of the forward or reverse rotation of the motor. A +10 V is outputted at the maximum revolution 4,500/6,000 rpm.

- 2) Use the following speedmeter (DC voltmeter)
 - One-sided deflection DC voltmeter
 - DC voltage 10 V full scale
 - Internal resistance higher than 10 kilo ohms

Example) DC voltmeter LM-80: Kuwano Electrical Manufacturing Co., Ltd.

- 3) The speed indication voltage is used for the speedometer, and the forward rotation/reverse rotation output voltages are not calibrated. The voltage accuracy is max. ±3%.

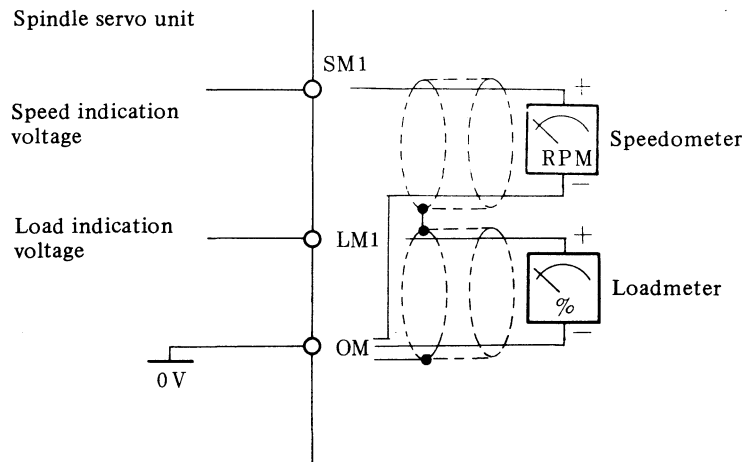

- 4) SM1, LM1, and OM indication interface can be used from terminal board TB for models 6S - 22S as well as connector CN1.
Use a 2-conductor shielded cable.

10.7 Load Indication Voltage (LM1, OM)

- 1) The load indicator indicates the load factor, which is the ratio of the load to the maximum output obtainable by the spindle motor at the input voltage and working revolutions when the machine tool spindle is rotating without load or when cutting is in progress.
- 2) The revolutions-to-spindle motor output relation, revolutions-to-torque relation and revolutions-to-indicating voltage relation are as illustrated below approximately when the rated input voltage is applied.

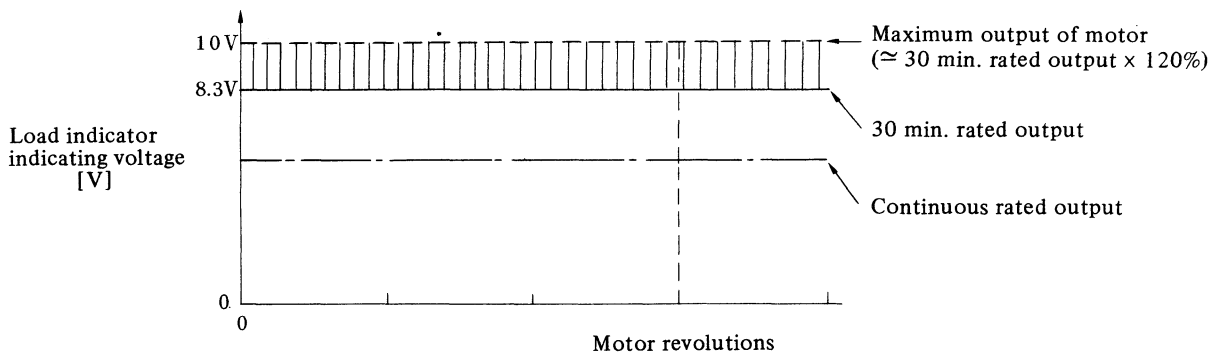
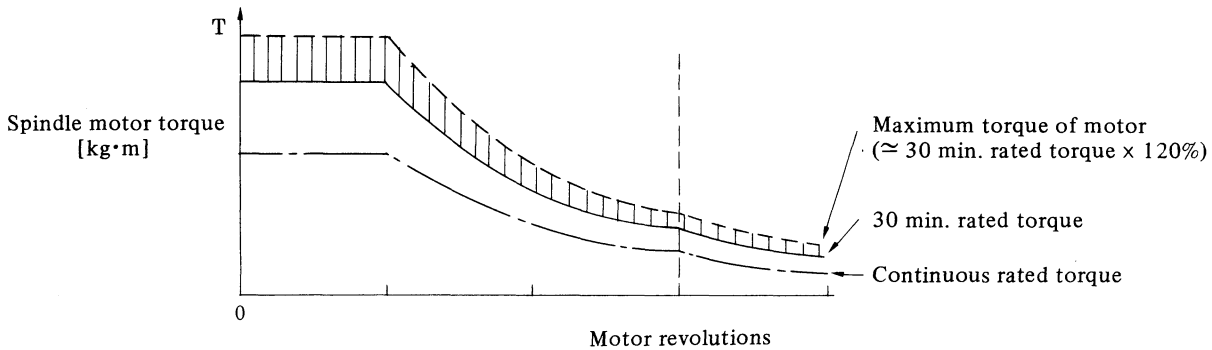
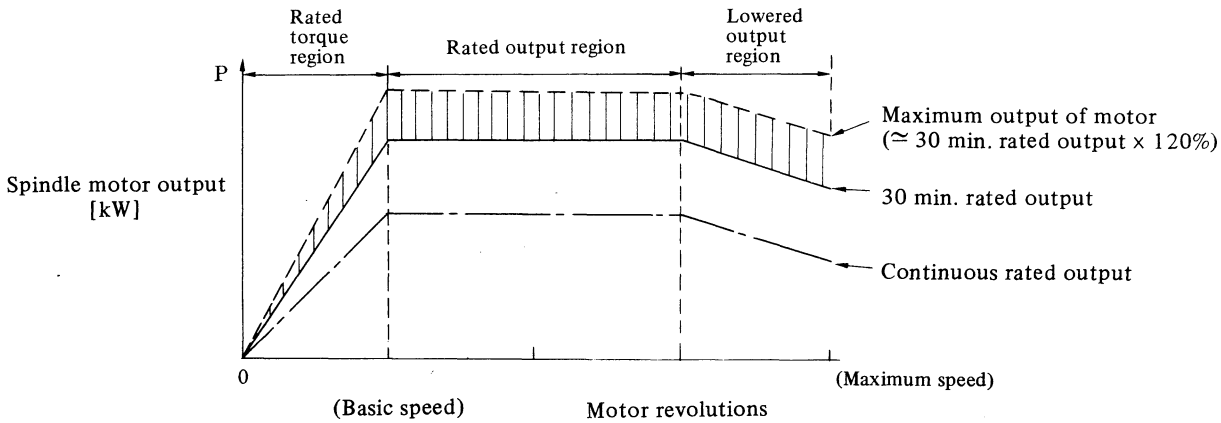

- 3) The relation between each spindle motor output and the indicating voltage of the load indicator is as shown in Table 10.7 (a), assuming that the continuous rated output of the spindle motor is 100%.

- 4) Three types of indications of the load indicator may be considered approximately from Table 10.7 (a). For the indication of the load indicator in this case, refer to examples shown in Table 10.7 (b).
- 5) Machine tool builders are requested to prepare a load indicator (DC voltmeter) which complies with the following specification.
- One-side deflecting DC voltmeter
 - DC voltage 10 V, full scale
 - Internal resistance 10 kilo ohms
- Example) DC voltmeter LM-80 made by KUWANO DENKI
- 6) The indication interface of these signals are usable from the terminal block TB in addition to the connector CN1. (Models 6S - 22S) When TB is used, use 2-core shielded cable.

Table 10.7 (a) Relation between each spindle motor output and indicating voltage of load indicator

Model	Output (kW)	Indicating voltage of load indicator (V) (Note)	Ratio assuming that continuous rated is 100% (%)	Example of load indicator	
				Type of applicable load indicator	Ratio to full scale (%)
1S 1S/15000	1.5	5.7	100	A	102.2
	2.2	8.3	147		150
	2.64	10.0	176		180
1.5S	1.1	2.5	100	D	100
	3.7	8.4	338		338
	4.4	10.0	400		400
2S 2S/15000	2.2	5.0	100	C	100
	3.7	8.3	166		166
	4.4	10.0	200		200
3S 3S/12000 8P	3.7	5.6	100	A	100.8
	5.5	8.3	148		150
	6.6	10.0	178		180
6S 6S/12000 12P, 6VH	5.5	6.1	100	A	109.8
	7.5	8.3	136		150
	9.0	10.0	164		180
8S 8S/8000 8VH	7.5	5.7	100	A	102.6
	11.0	8.3	146		150
	13.2	10.0	175		180
12S 12S/8000 22P, 12VH	11	6.1	100	A	109.8
	15	8.3	136		150
	18	10.0	164		180
15S 15S/8000 30P	15	6.7	100	B	100.5
	18.5	8.3	124		125
	22.2	10.0	149		150
18S 18S/6000 40P	18.5	7.0	100	B	105
	22.0	8.3	118		125
	26.4	10.0	142		150
22S 22S/6000	22.0	7.0	100	B	105
	26.0	8.3	118		125
	31.2	10.0	142		150

Note) Accuracy of the load indicator voltage depends upon the speed used or the input voltage. The maximum deviation is approximately $\pm 15\%$.

Table 10.7 (b) Examples of load indicator type

Type	Indication of load indicator	Model
A	<p>Color division: White band, Yellow band, Red band</p> <p>Indication: 0, 50, 100, 150, 180</p> <p>Correspondence to voltage: 0V, 5.55V, 8.3V, 10.0V</p>	<p>1S, 3S, 6S, 8S, 12S, 1S/15000, 3S/12000, 6S/12000, 8S/8000, 12S/8000, 8P, 12P, 22P, 50P, 6VH, 8VH, 12VH</p>
B	<p>Color division: White band, Yellow band, Red band</p> <p>Indication: 0, 50, 100, 125, 150</p> <p>Correspondence to voltage: 0V, 6.66V, 8.3V, 10.0V</p>	<p>15S, 18S, 22S, 18S/6000, 22S/6000, 15P, 18P, 30P, 40P</p>
C	<p>Color division: White band, Yellow band, Red band</p> <p>Indication: 0, 50, 100, 150, 166, 200</p> <p>Correspondence to voltage: 0V, 5.0V, 8.3V, 10.0V</p>	<p>2S, 2S/15000</p>
D	<p>Color division: White band, Yellow band, Red band</p> <p>Indication: 0, 100, 200, 300, 338, 400</p> <p>Correspondence to voltage: 0V, 5.0V, 8.3V, 10.0V</p>	<p>1.5S</p>

11. RIGID TAPPING

Response characteristics needed for the normal operation mode and the rigid tapping mode are different from each other when using AC spindle motor. Noise on the spindle may possibly get louder depending on machines when response characteristics are improved. In this case set the parameter for rigid tapping according to the type of machine.

1) Selecting rigid tapping mode

Select the parameter number **F-31** to display **0001**.

2) Contact signal TLML-OT (TLM-OT: Models 1S - 3S)

Treat the power sequence to close the contact signal TLML-OT (TLM-OT) when rigid tapping is made.

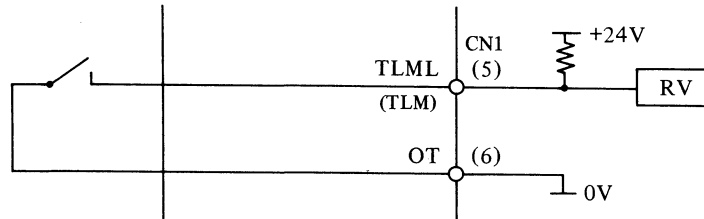

3) Confirming the ready signal

Check the contact of the control output signals TLM5 and 6 is closed as the ready signal, to start rigid tap machining.

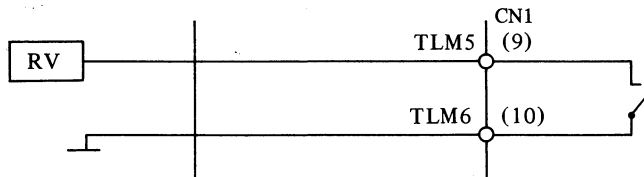

Note) Models 1S - 3S are output by an open collector transistor (polarized).

4) Improving response characteristics

Select the parameter number **F-34** to display **0100**.

Lessen the setting value from **0100** to input proper data, when the spindle on the machine makes noise. Setting range: 0100 - 0010

Cautions on application

(Note) that the torque limit command signal TLML cannot be used when the rigid tapping mode is selected.

Use the torque limit command signal TLMH when torque limit is necessary.

III. AC SPINDLE MOTOR P series

1. GENERAL

The AC spindle motor P series is suitable for structural rationalization by eliminating the machine spindle gear box.

2. FEATURES

- 1) As the rated output range is wide at 1:8, a gear box structure for speed change is not required, thereby allowing the structure of the machine to be simplified.
Accordingly, vibration and noise caused by the gear box structure is also eliminated.
- 2) Improvement in efficiency of construction equipment
In the conventional motor, it was necessary to stop the spindle when switching the gear to change the speed. However, the P series AC spindle motor reduces unnecessary use of time, other than that needed for machining, to a minimum by eliminating gear switching.
- 3) Despite a compact configuration, a large low-speed torque can be obtained.
- 4) Similar to the standard series, the method of fan exhaust can be selected from either a exhaust front type or exhaust rear type, thus preventing heat deformation of the machine.

3. SPECIFICATIONS

Series				P series								
Item		Model		8P	12P	15P	18P	22P	30P	40P	50P	
AC spindle motor	Out-put	Continuous rating(*1)	kW (HP)	3.7 (5.0)	5.5 (7.4)	7.5 (10.0)	9 (12.0)	11 (14.7)	15 (20.1)	18.5 (24.8)	22 (29.5)	
		30-min. rating(*1)	kW (HP)	5.5 (7.4)	7.5 (10.0)	9 (12.0)	11 (14.7)	15 (20.1)	18.5 (24.8)	22(*5) (29.5)	30(*5) (40.2)	
		50% ED(*1,*2)	kW (HP)	5.5 (7.4)	7.5 (10.0)	9 (12.0)	11 (14.7)	15 (20.1)	18.5 (24.8)	22 (29.5)	30 (40.2)	
	Rotation speed	Basal speed	rpm	750	750	750	750	750	750	575	575	575
		Maximum speed	rpm	6000	6000	6000	6000	6000	6000	4500	4500	4500
	Output torque(*4)	N.m (kg.cm)	47.1 (480)	70 (714)	95.4 (974)	114.5 (1169)	140 (1428)	249 (2540)	307 (3133)	365 (3726)		
	GD ²	kg.m ²	0.11	0.36	0.36	0.51	0.51	1.18	1.18	2.48		
	Rotor inertia	N.m.sec ² (kg.cm.sec ²)	0.027 (0.28)	0.091 (0.93)	0.091 (0.93)	0.126 (1.29)	0.126 (1.29)	0.29 (3.0)	0.29 (3.0)	0.62 (6.33)		
	Weight	kg	80	110	110	143	143	250	250	460		
	Vibration		V5								V10	
	Noise		75dB								80dB	
	Cooling system		Totally enclosed external fan type									
	Mounting		Use the output axis in the horizontal or vertical direction									
	Overload tolerance (1 min.)		120% of 30-min. rating									
	Insulation		F type									
	Ambient temperature		0 - 40°C									
Painting color		Munsell N2.5										
Spare parts		Pulse generator, Thermostat										
Bearing lubrication		Grease										
AC spindle servo unit	30-min. rated power supply capacity	kVA	9	12	15	17	22	26	32	44		
	Power supply(*3)		AC 200/220/230V, 10%/-15%; 50/60Hz <u>±</u> 1Hz									
	Main circuit system		Transistor PWM inverter									
	Feedback system		Speed feedback by pulse generator									
	Braking system		Regenerative braking									
	Input command voltage		DC +10V (High speed) - 0V (Stop)									
	Speed control range		60 - 6000rpm (Speed ratio 1:100)						45 - 4500rpm (Speed ratio 1:100)			
	Speed fluctuation		10% of maximum speed for load fluctuation in the range of 10% - 100%									

(*1) Rated output is guaranteed in the rated power supply voltage. When the input power supply voltage fluctuates, even within the allowable fluctuation range, rated output may not be obtained.

(*2) With a cycle time of 10 min. and 50% ED: the ON period will be 5 mins. and the OFF period, 5 min.

(*3) A transformer is needed when the power supply voltage is outside the voltage stated in this manual.

(*4) Output torque is expressed as "Continuous rated torque in the rated torque range".

(*5) Guaranteed when separately stipulated conditions are satisfied.

4. OUTPUT CHARACTERISTICS

1) Model 8P

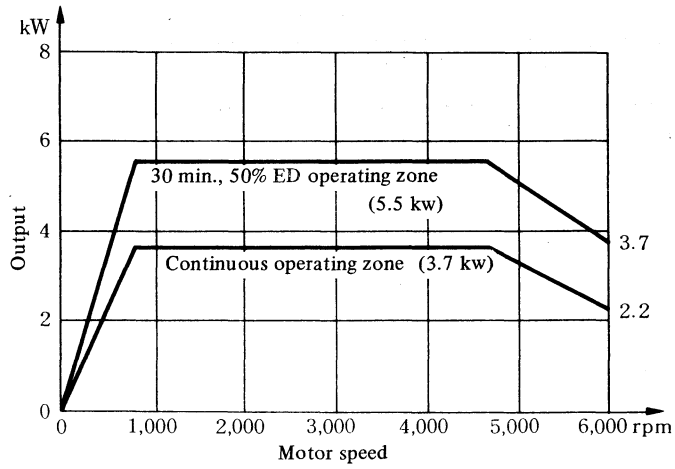

2) Model 12P

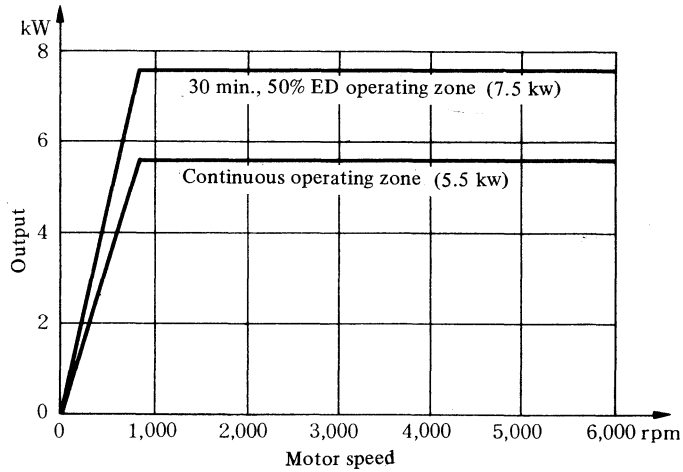

3) Model 15P

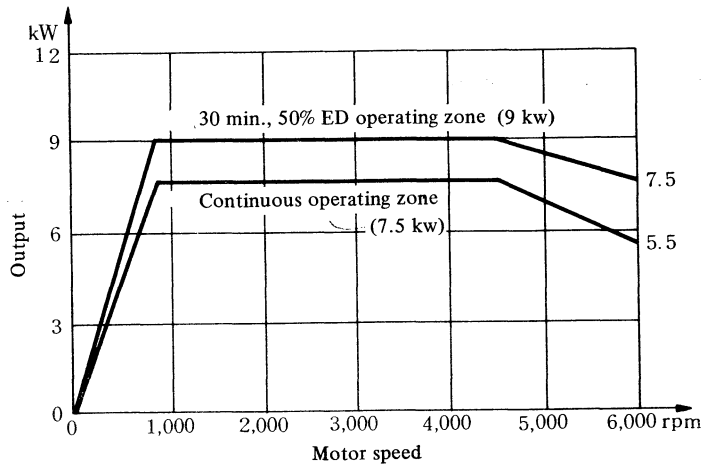

4) Model 18P

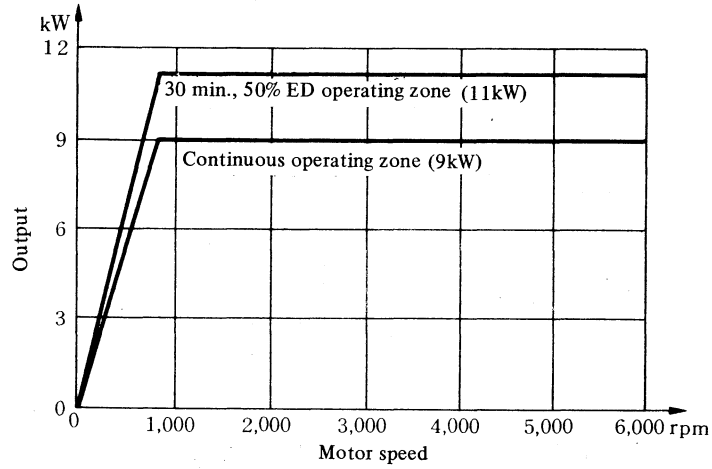

5) Model 22P

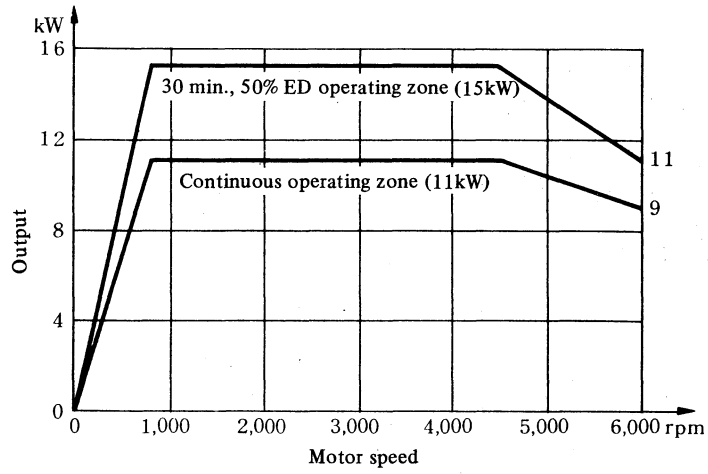

6) Model 30P

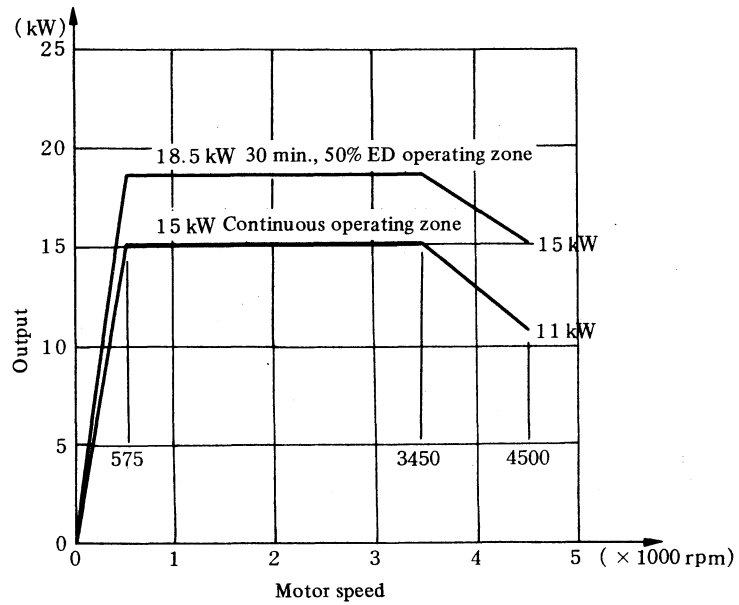

7) Model 40P

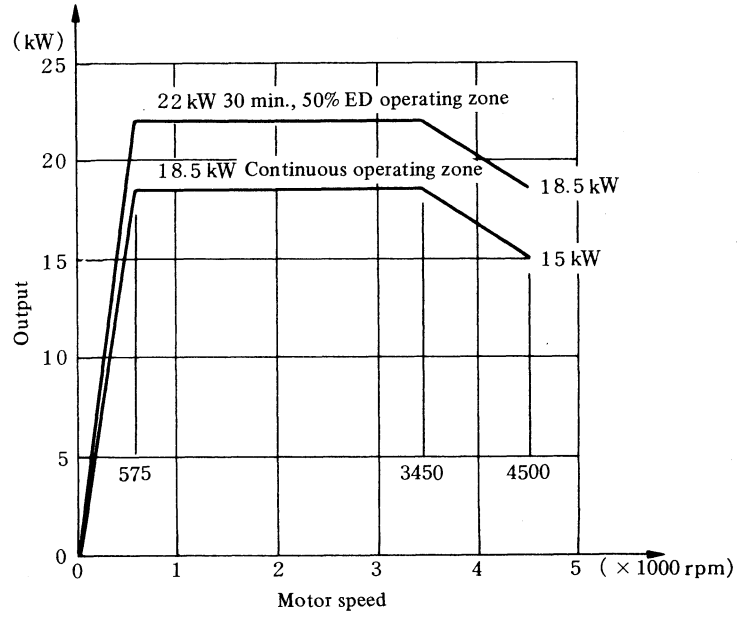

8) Model 50P

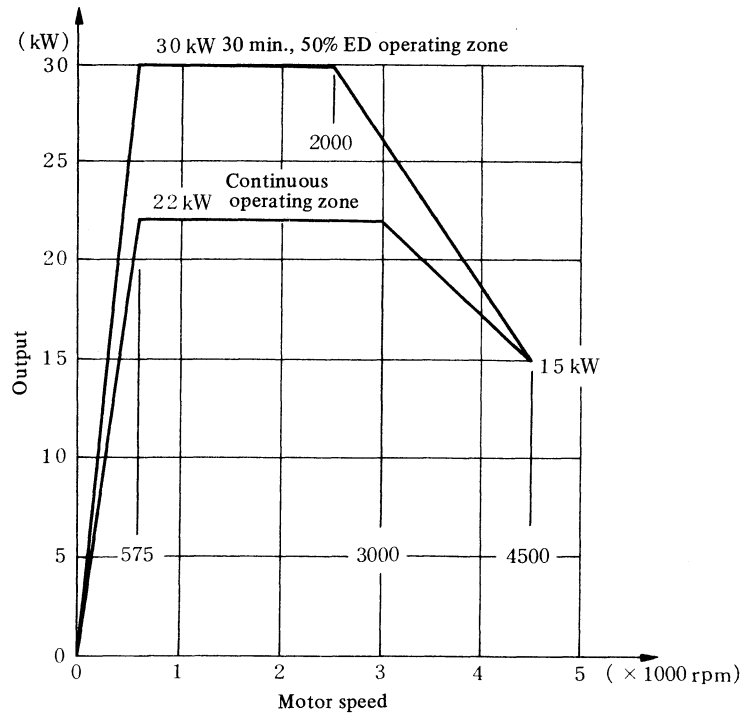

Note) When the ambient temperature of the model 40P servo unit is high, the time of continuous use at the motor's 30-min. rated output is shown in the figure below in terms of servo unit thermal limitation.

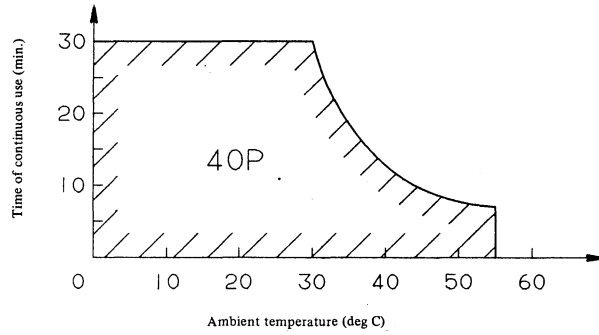

Note 1) Use four three-phase fan motors (model 5915PT-20W-B30-504 made by MINEBEA or equivalent).

Note 2) For duct dimensions, refer to the following figure.

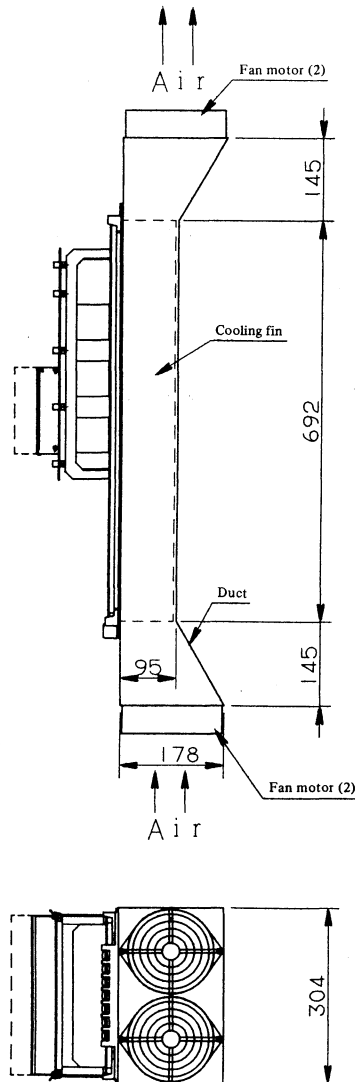

Reference fig. of the Model 40P servo unit external cooling fin method of cooling

5. ORDER SPECIFICATIONS

5.1 AC Spindle Motor

Name		Specification number	Description
Model 8P	Flange mounting	A06B-0725-B102	6000 rpm, has key, has oil seal, exhaust rear
		-B103	6000 rpm, has key, has oil seal, exhaust front
		-B302	6000 rpm, no key, has oil seal, exhaust rear
		-B303	6000 rpm, no key, has oil seal, exhaust front
	Foot mounting	A06B-0725-B202	6000 rpm, has key, no oil seal, exhaust rear
		-B203	6000 rpm, has key, no oil seal, exhaust front
		-B402	6000 rpm, no key, no oil seal, exhaust rear
		-B403	6000 rpm, no key, no oil seal, exhaust front
Model 12P	Flange mounting	A06B-0726-B102	6000 rpm, has key, has oil seal, exhaust rear
		-B103	6000 rpm, has key, has oil seal, exhaust front
		-B302	6000 rpm, no key, has oil seal, exhaust rear
		-B303	6000 rpm, no key, has oil seal, exhaust front
	Foot mounting	A06B-0726-B202	6000 rpm, has key, no oil seal, exhaust rear
		-B203	6000 rpm, has key, no oil seal, exhaust front
		-B402	6000 rpm, no key, no oil seal, exhaust rear
		-B403	6000 rpm, no key, no oil seal, exhaust front

Name		Specification number	Description
Model 15P	Flange mounting	A06B-0727-B102 -B103 -B302 -B303	6000 rpm, has key, has oil seal, exhaust rear 6000 rpm, has key, has oil seal, exhaust front 6000 rpm, no key, has oil seal, exhaust rear 6000 rpm, no key, has oil seal, exhaust front
	Foot mounting	A06B-0727-B202 -B203 -B402 -B403	6000 rpm, has key, no oil seal, exhaust rear 6000 rpm, has key, no oil seal, exhaust front 6000 rpm, no key, no oil seal, exhaust rear 6000 rpm, no key, no oil seal, exhaust front
Model 18P	Flange mounting	A06B-0728-B102 -B103 -B302 -B303	6000 rpm, has key, has oil seal, exhaust rear 6000 rpm, has key, has oil seal, exhaust front 6000 rpm, no key, has oil seal, exhaust rear 6000 rpm, no key, has oil seal, exhaust front
	Foot mounting	A06B-0728-B202 -B203 -B402 -B403	6000 rpm, has key, no oil seal, exhaust rear 6000 rpm, has key, no oil seal, exhaust front 6000 rpm, no key, no oil seal, exhaust rear 6000 rpm, no key, no oil seal, exhaust front
Model 22P	Flange mounting	A06B-0729-B102 -B103 -B302 -B303	6000 rpm, has key, has oil seal, exhaust rear 6000 rpm, has key, has oil seal, exhaust front 6000 rpm, no key, has oil seal, exhaust rear 6000 rpm, no key, has oil seal, exhaust front
	Foot mounting	A06B-0729-B202 -B203 -B402 -B403	6000 rpm, has key, no oil seal, exhaust rear 6000 rpm, has key, no oil seal, exhaust front 6000 rpm, no key, no oil seal, exhaust rear 6000 rpm, no key, no oil seal, exhaust front

Name		Specification number	Description
Model 30P	Flange mounting	A06B-0730-B100	4500 rpm, has key, has oil seal, exhaust rear
		-B101	4500 rpm, has key, has oil seal, exhaust front
		-B300	4500 rpm, no key, has oil seal, exhaust rear
		-B301	4500 rpm, no key, has oil seal, exhaust front
	Foot mounting	A06B-0730-B200	4500 rpm, has key, no oil seal, exhaust rear
		-B201	4500 rpm, has key, no oil seal, exhaust front
-B400		4500 rpm, no key, no oil seal, exhaust rear	
-B401		4500 rpm, no key, no oil seal, exhaust front	
Model 40P	Flange mounting	A06B-0731-B100	4500 rpm, has key, has oil seal, exhaust rear
		-B101	4500 rpm, has key, has oil seal, exhaust front
		-B300	4500 rpm, no key, has oil seal, exhaust rear
		-B301	4500 rpm, no key, has oil seal, exhaust front
	Foot mounting	A06B-0731-B200	4500 rpm, has key, no oil seal, exhaust rear
		-B201	4500 rpm, has key, no oil seal, exhaust front
-B400		4500 rpm, no key, no oil seal, exhaust rear	
-B401		4500 rpm, no key, no oil seal, exhaust front	
Model 50P	Foot mounting	A06B-0732-B206	4500 rpm, has key, no oil seal, exhaust rear
		-B207	4500 rpm, has key, no oil seal, exhaust front
		-B406	4500 rpm, no key, no oil seal, exhaust rear
		-B407	4500 rpm, no key, no oil seal, exhaust front

5.2 AC Spindle Servo Unit

Classification		Specification drawing number	Description	
Basic	For the spindle control unit model 8P	A06B-6059-H206 #H550	External radiation type, 6000 rpm	
	For the spindle control unit model 12P	A06B-6059-H206 #H551	External radiation type, 6000 rpm	
	For the spindle control unit model 15P	A06B-6059-H208 #H552	External radiation type, 6000 rpm	
	For the spindle control unit model 18P	A06B-6059-H212 #H553	External radiation type, 6000 rpm	
	For the spindle control unit model 22P	A06B-6059-H215 #H554	External radiation type, 6000 rpm	
	For the spindle control unit model 30P	A06B-6059-H218 #H555	External radiation type, 4500 rpm	
	For the spindle control unit model 40P	A06B-6059-H222 #H556	External radiation type, 4500 rpm	
	For the spindle control unit model 50P	A06B-6055-H322 #H551	Internal radiation type, 4500 rpm	
		A06B-6055-H422 #H551	External ventilation type	
Basic	Connectors	A06B-6059-K103	Soldered type For models 8P - 40P	
		A06B-6059-K104	Crimp type For models 8P - 40P	
	Fuses	A06B-6059-K012	For models 8P - 18P	
		A06B-6059-K022	For models 22P - 40P	
Option	Speed gain switching circuit	A06B-6059-J700	For models 8P - 40P	
Option	Power supply transformer	A06B-6059-J006	For models 8P - 15P	Primary side 380VAC 415VAC 460VAC Secondary side 200VAC
		A06B-6059-J007	For models 18P and 22P	
		A06B-6059-J010	For models 30P - 50P	
	Unit adapter	A06B-6059-K031	For models 8P - 18P	
		A06B-6059-K032	For models 22P - 30P	

- (*1) For optional orientation, refer to the items related to spindle orientation in Part V.
- (*2) For details such as option of spindle control unit for model 50P and the like, refer to FANUC AC SPINDLE MOTOR series DESCRIPTIONS B-53422E/10 or earlier.

6. CONNECTIONS

Models 8P - 50P

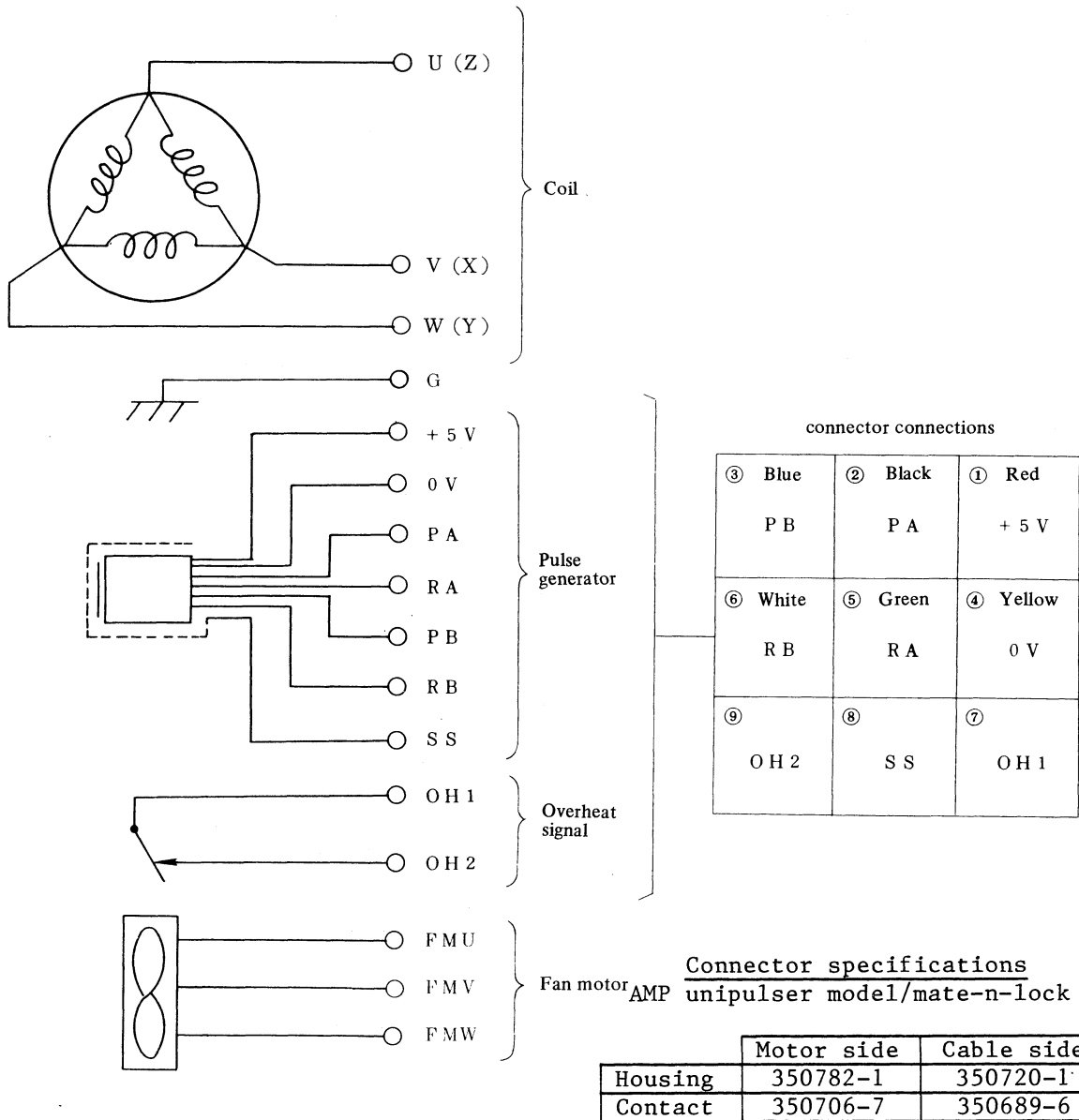

The pulse generator and overheated signals are connected to the AMP connector. The others are connected to the terminal block.

Terminal block screw dimensions

Model \ Terminal name	U, V, W, G	FMU - FMW
8P - 22P	M5	M4
30P, 40P	M8	M4
50P	M8	M3.5

7. PRECAUTIONS RELATED TO USE

1) Terminal box

The terminal box is made from plastic. Therefore, the metal plate that was attached to both side faces of the present terminal box have been discontinued. Mount the conduit by directly fastening with a nut, as shown in the diagram below. (Model 8P - 40P)

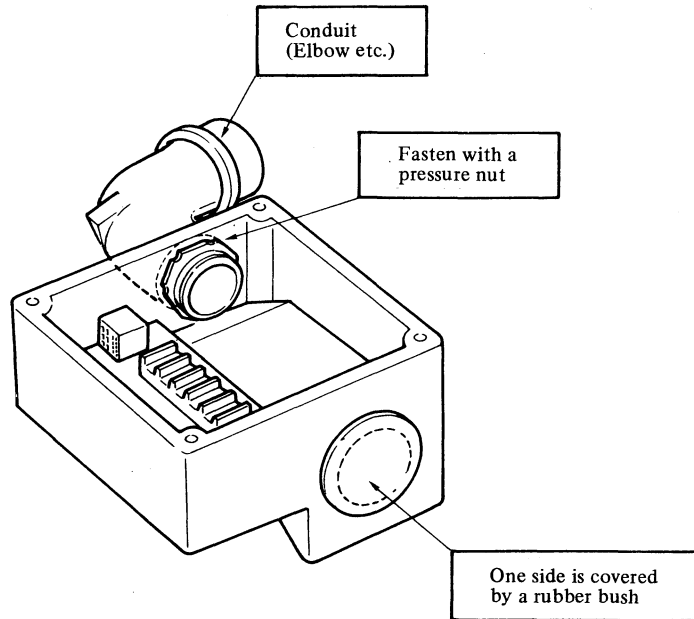

2) Allowable radial load

Use the motor output shaft with allowable radial load shown in the below table or less.

Motor model	Allowable radial load	Output shaft bearing
Model 8P	300 kg	6210
Models 12P, 15P	300 kg	6312
Models 18P, 22P	450 kg	
Models 30P, 40P	550 kg	6314
Model 50P	1100 kg	6317

Note) The above-listed allowable radial loads are values obtained when the load was applied to the end of the output shaft. In cases when the center of belt tension is beyond the end of the output shaft, the values for allowable load will be smaller than those given above.

8. EXTERNAL DIMENSIONS

8.1 AC Spindle Motor Model 8P

a) Flange type

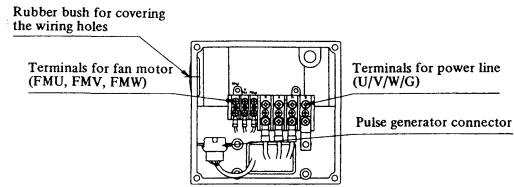

① Blue PB	② Black PA	③ Red +5V
④ White RB	⑤ Green RA	⑥ Yellow 0V
⑦ OH2	⑧ SS	⑨ OH1

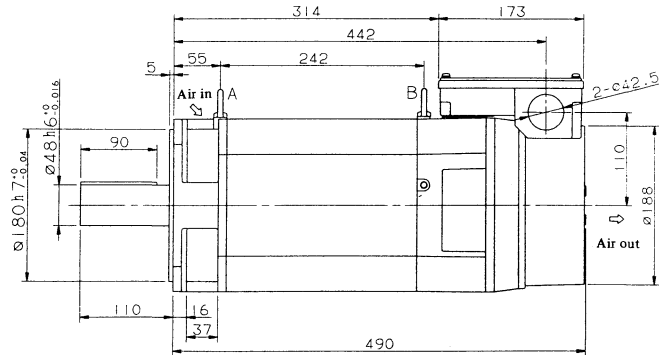
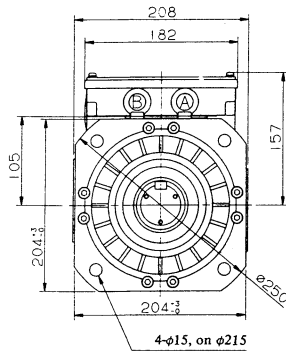

- Note) 1. The output shaft should be horizontal or vertical down ward in use.
2. Use hexagon bolts M12, length 40 mm or less as mounting bolts.
3. The motor in which cooling air flow direction is reversed is also available.

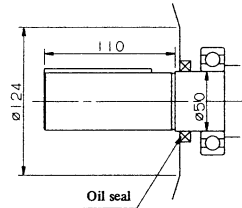
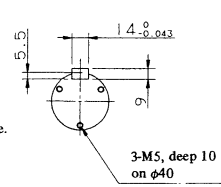

b) Foot mounting type

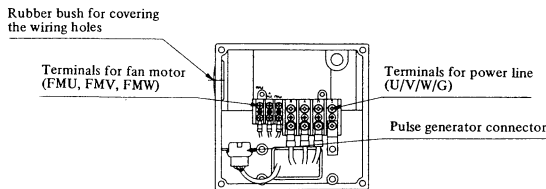

① Blue PB	② Black PA	③ Red +5V
④ White RB	⑤ Green RA	⑥ Yellow 0V
⑦ OH2	⑧ SS	⑨ OH1

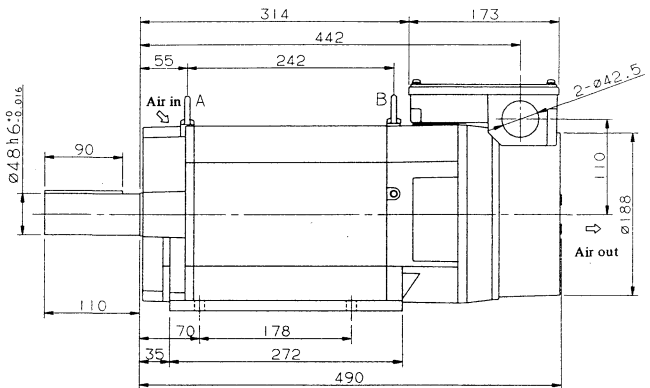
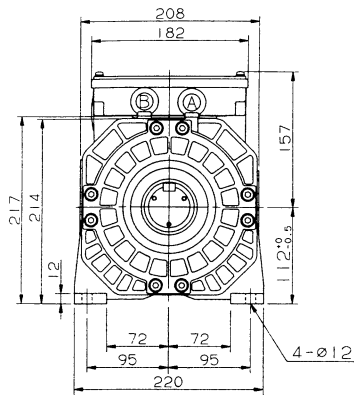

- Note) 1. The output shaft should be horizontal or vertical down ward in use.
2. Use hexagon bolts M10, length 30 mm or less as mounting bolts.
3. The motor in which cooling air flow direction is reversed is also available.

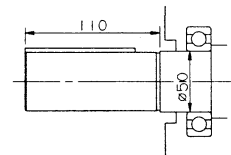
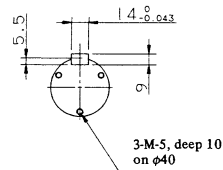

8.2 AC Spindle Motor Model 12P, 15P

a) Flange type

Rubber bush for covering the wiring holes

Terminals for fan motor (FMU, FMV, FMW)

Terminals for power line (U/V/W/G)

Pulse generator connector

Ⓟ Blue	Ⓟ Black	Ⓟ Red
PB	PA	+5V
Ⓟ White	Ⓟ Green	Ⓟ Yellow
RB	RA	OV
Ⓟ	Ⓟ	Ⓟ
OH2	SS	OH1

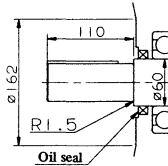
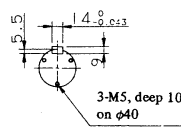
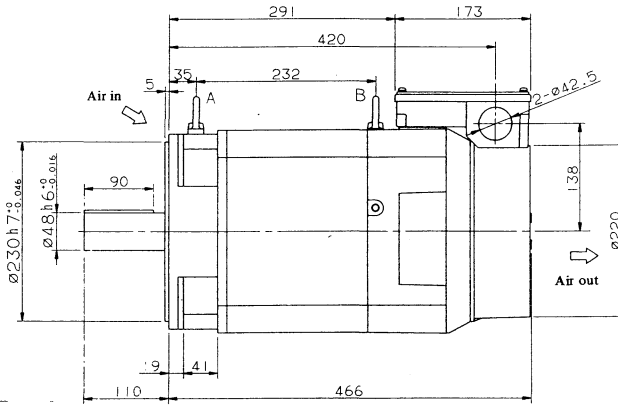
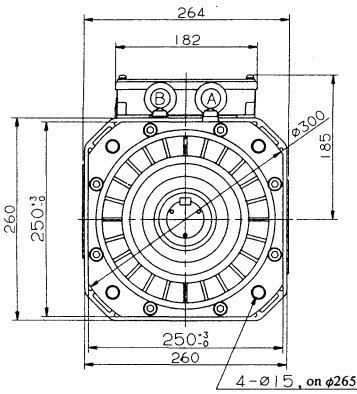

- Note) 1. The output shaft should be horizontal or vertical down ward in use.
 2. Use hexagon bolts M12, length 45 mm or less as mounting bolts.
 3. The motor in which cooling air flow direction is reversed is also available.

b) Foot mounting type

Rubber bush for covering the wiring holes

Terminals for fan motor (FMU, FMV, FMW)

Terminals for power line (U/V/W/G)

Pulse generator connector

Ⓟ Blue	Ⓟ Black	Ⓟ Red
PB	PA	+5V
Ⓟ White	Ⓟ Green	Ⓟ Yellow
RB	RA	OV
Ⓟ	Ⓟ	Ⓟ
OH2	SS	OH1

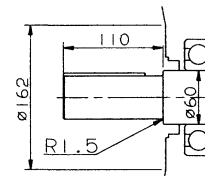
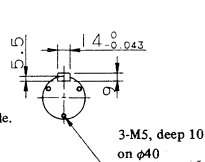
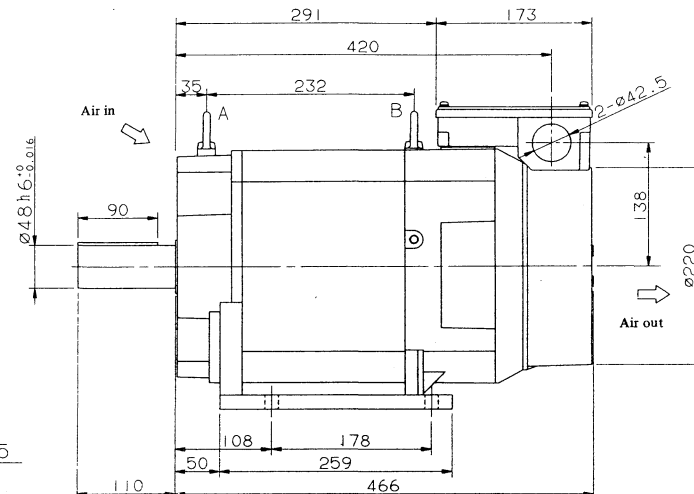
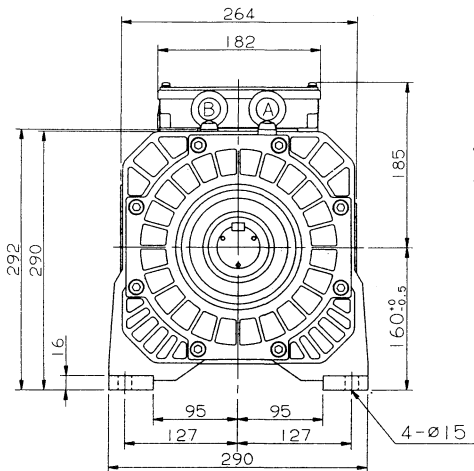

- Note) 1. The output shaft should be horizontal or vertical down ward in use.
 2. Use hexagon bolts M12, length 45 mm or less as mounting bolts.
 3. The motor in which cooling air flow direction is reversed is also available.

8.3 AC Spindle Motor Model 18P, 22P

a) Flange type

Rubber bush for covering the wiring holes

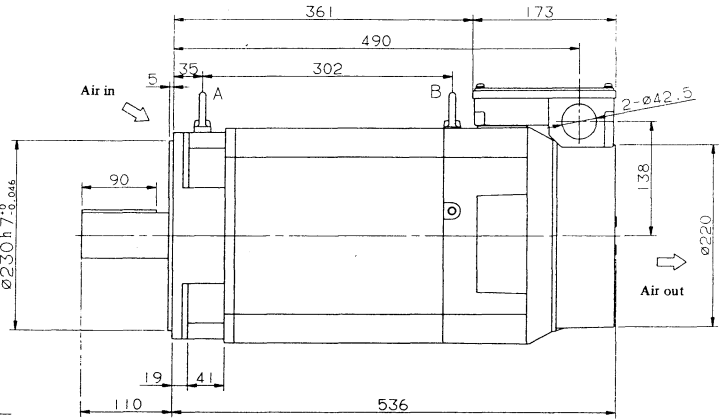
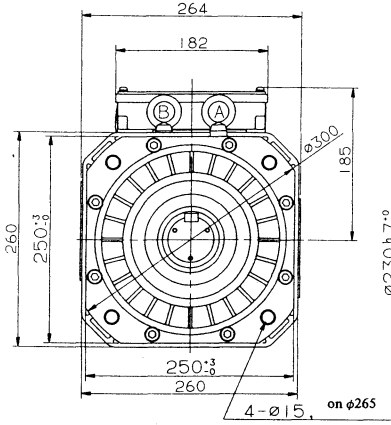
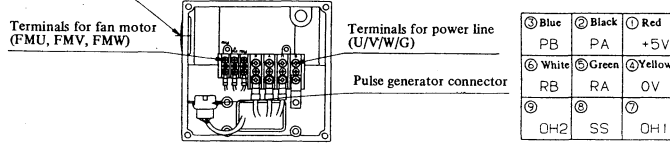

- Note) 1. The output shaft should be horizontal or vertical down ward in use.
 2. Use hexagon bolts M12, length 45 mm or less as mounting bolts.
 3. The motor in which cooling air flow direction is reversed is also available.

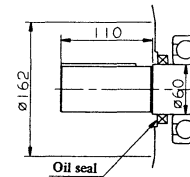
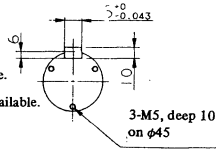

b) Foot mounting type

Rubber bush for covering the wiring holes

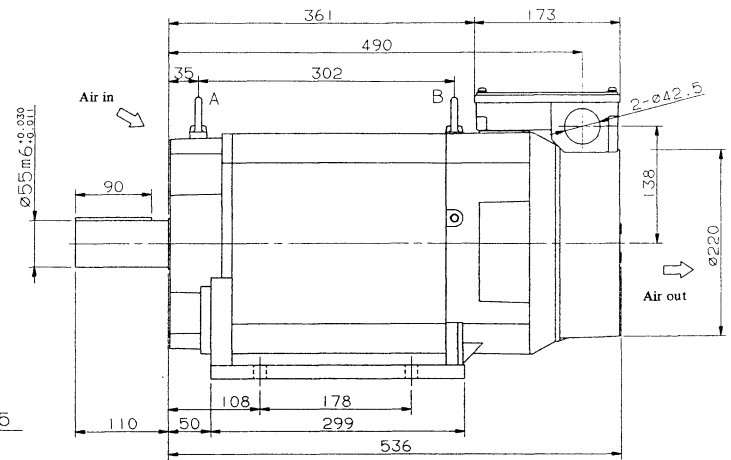
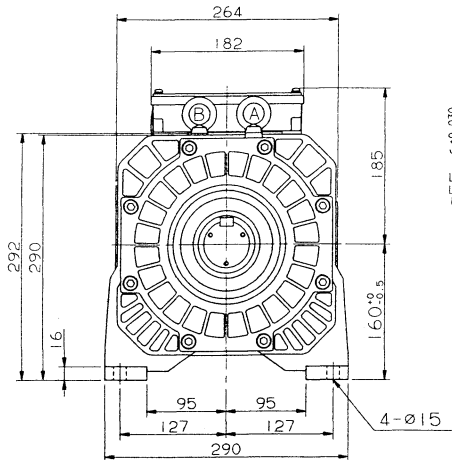
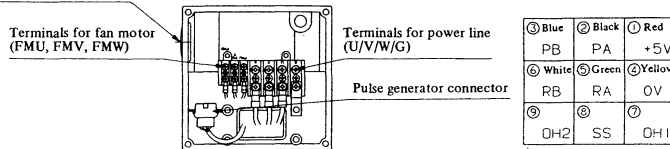

- Note) 1. The output shaft should be horizontal or vertical down ward in use.
 2. Use hexagon bolts M12, length 45 mm or less as mounting bolts.
 3. The motor in which cooling air flow direction is reversed is also available.

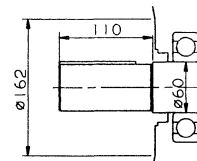
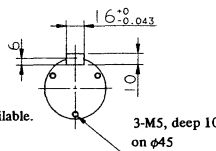

8.4 AC Spindle Motor Model 30P, 40P

a) Flange type

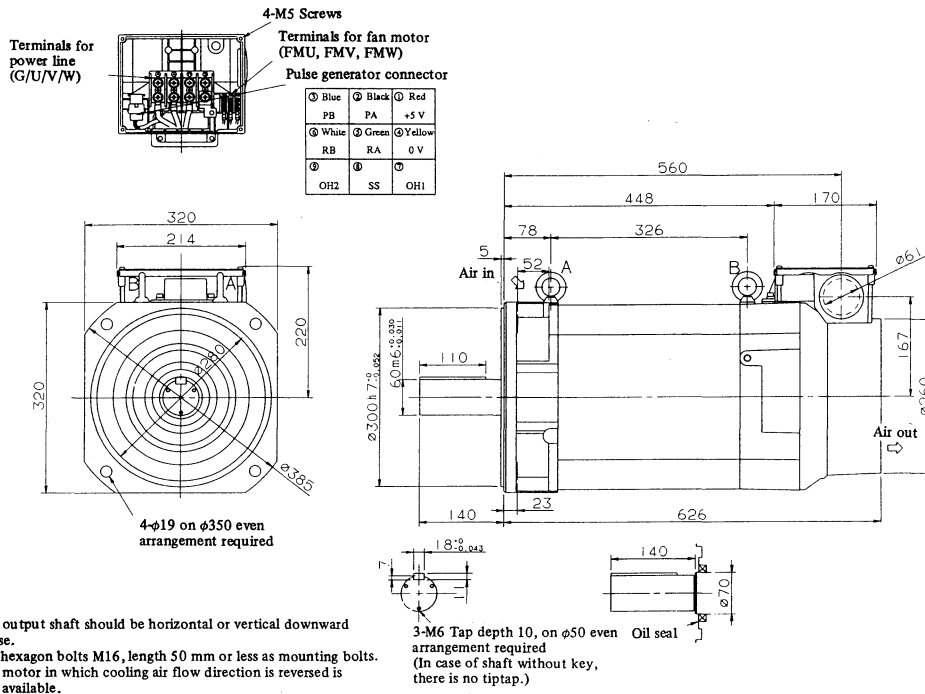

b) Foot mounting type

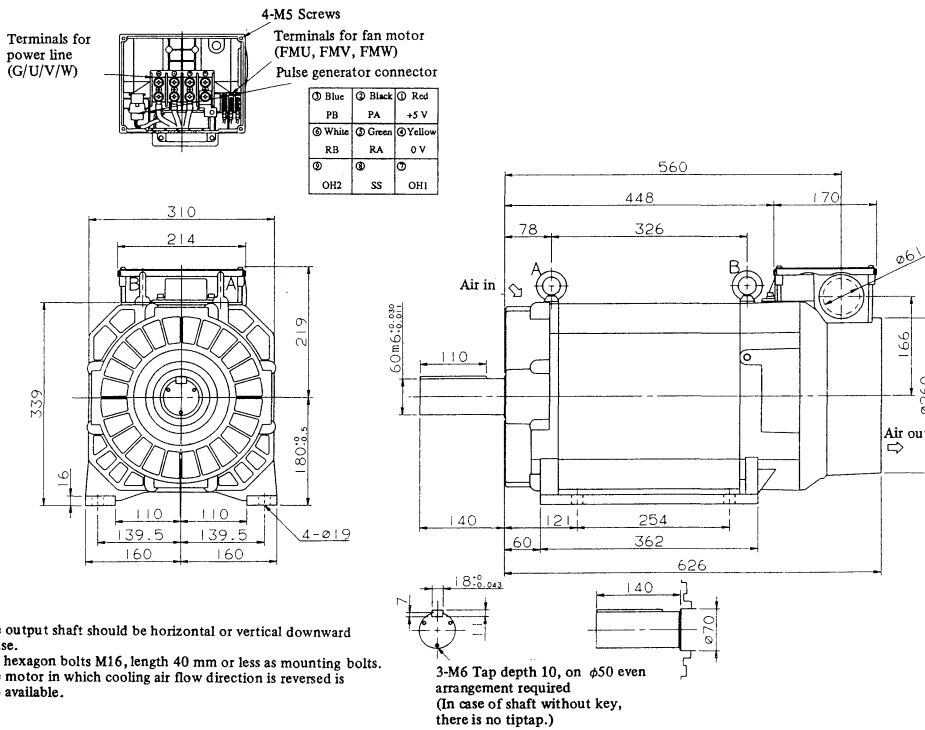

8.5 AC Spindle Motor Model 50P (Foot Mounting Type)

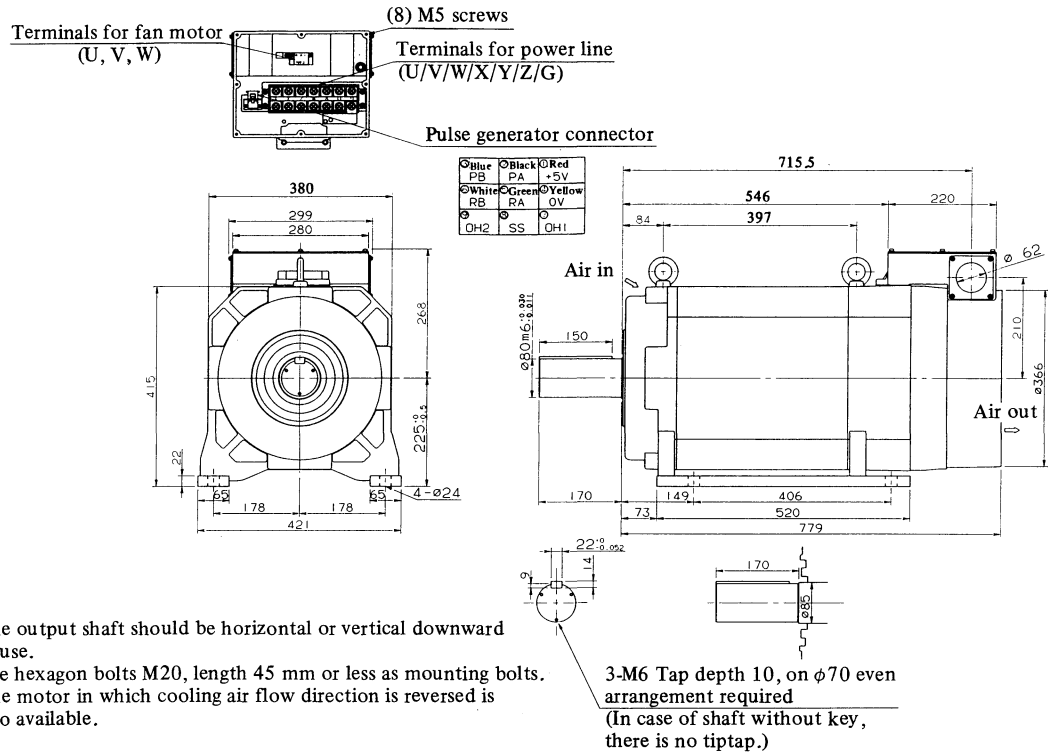

8.6 AC Spindle Servo Unit

For the external dimensions of models 8P to 40P, refer to AC SPINDLE SERVO UNIT S series in Part II. For model 50P, refer to FANUC AC SPINDLE MOTOR series DESCRIPTIONS B-53422E/10 or the later.

IV. FANUC AC SPINDLE MOTOR VH series

1. GENERAL

The AC SPINDLE MOTOR VH series is able to operate at high speeds with minimal heat rise due to its use of an oil/air lubrication method and a unique oil cooling system which utilizes a piped cooling oil mechanism.

2. FEATURES

- 1) Because the VH SERIES uses an oil/air lubrication system, thereby eliminating worries about lubrication oil life which accompanies grease lubricated systems, it is able to run at high speed for extended hours.
- 2) In the VH SERIES, the forward flange and the stator core outer surface are oil cooled, enabling the motor to run at high speed for extended hours with minimal heat rise throughout the motor. This minimizes any heat deformation effects on the machine.
- 3) Vibrations are minimized even in the high rotation speed range, due to strict dynamic balance corrections on the rotor and the use of high precision bearings.
- 4) Since no cooling fans are used, the noise level is low.

3. SPECIFICATIONS

3.1 Specification Table

3.1.1 AC spindle motor VH series

Table 3.1 Specification table

Item		Name	6 VH	8 VH	12 VH
Output *1	Continuous rated	kW	5.5	7.5	11
	30-min. rated		7.5	11	15
	50%ED rated *2		7.5	11	15
Rotation speed	Base speed	rpm	5,000	5,000	2,500
	Maximum speed		20,000	20,000	15,000
Output torque (continuous rated torque in the rated torque range)		Nm	10.5	14.3	42
		kgcm	107	146	428
GD ²		kgm ²	0.086	0.11	0.36
Rotor inertia		kgcm sec ²	0.22	0.28	0.93
Weight		kg	60	80	110
Cooling system			Liquid cooling system		
Cooler capacity		kcal/h	1500 - 2000		2000 - 3000
Bearing lubrication system			Oil air lubrication		
Allowable radial load			80 kg or less at the tip of the output shaft		
Installation			The output shaft should be horizontal (underside the oil air drain hole) or vertically downward.		
Allowable overload capacity (for 1 min.)			120% of 30-min. rated output		
Insulation			Class F		
Ambient temperature			0 - 40°C		
Noise			75 dB		
Vibration			V 5		
Painting color			Munsell system N2.5		
Accessories			Pulse generator, thermostat		

- (*1) The rated output is guaranteed at the rated input voltage (200V/220V/230V AC). If the input voltage fluctuates, it is possible that the rated output cannot be obtained even when such fluctuations are within the allowable fluctuation range.
- (*2) With a cycle time of 10 minutes and 50%ED: the ON period will be 5 min. and the OFF period 5 min.

3.1.2 AC spindle servo unit VH series

Name		6 VH	8 VH	12 VH
Item				
30-min. rated power source capacity	kVA	17	22	26
Power source *1		200V/220V/230VAC+10%, -15% 50/60Hz <u>+1</u> Hz		
Main circuit system		Transistor PWM inverter		
Feed back system		Velocity feed back by pulse generator		
Braking system		Regenerative braking		
Input command voltage		+10V DC: Maximum speed, 0V: Stop		
Velocity control range	rpm	200 - 20,000	150 - 15,000	
Speed variation		Less than 0.1% of the maximum speed in the load variation range from 10 to 100%		
Cooling system		External radiation type *2		

- (*1) A transformer is needed when the power voltage is other than specified herein.
- (*2) No cooling fan, for heat radiating sections, is supplied with the SERVO UNIT. Cool the radiating sections with forced air with a 3m/sec-or-greater velocity using a fan, etc., when operating.

3.1.3 Miscellaneous

- 1) For detailed specifications on the AC SPINDLE SERVO UNIT for Models 8VH and 12VH, refer to the sections on Models 12S and 15S, respectively, in Part II. For detailed specifications and outline drawings of the AC SPINDLE SERVO UNIT for Model 6VH, refer to B-53422E/10 and following sections in the FANUC AC SPINDLE MOTOR SERIES Specifications Manual. For the display voltage and type of dynamometer, refer to section 10.7.
- 2) For cooling requirements for the AC SPINDLE SERVO UNIT, refer to the sections on 12S and 15S for Models 8VH and 12VH, respectively, in Chapter II, Section 10 "Cooling and setup requirements".

3.2 Oil Air Lubrication Conditions

Item	Setting condition
Oil supply	0.03 cc every 16 minutes
Oil type	Turbine oil or spindle oil, 32 cst or equivalent
Air supply	20 NL/min./bearing (dry air)
Air pressure	3.5 - 4.5 kg/cm ²
Drain piping	ID of $\phi 6$ or more, piping length within 300 mm

3.3 Motor Cooling Conditions

Item	Setting condition
Coolant	Turbine oil or spindle oil, 10 cst or less
Pressure in the outlet	Lower than 2.0 kg/cm ²
Flow rate	5 - 10 L/min
Oil temperature setting	30°C

3.4 Reference Drawing for Piping Parts

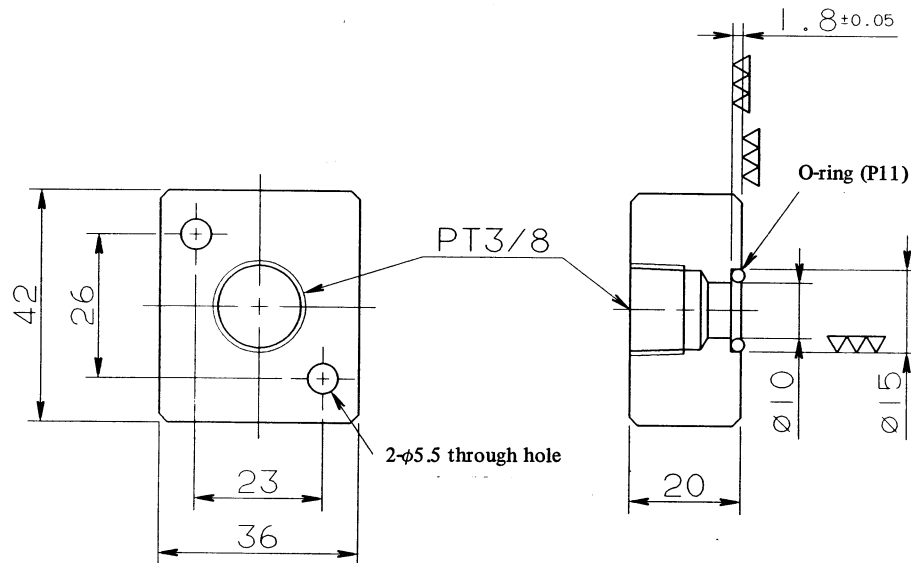

3.5 Output Characteristics

1) Model 6VH

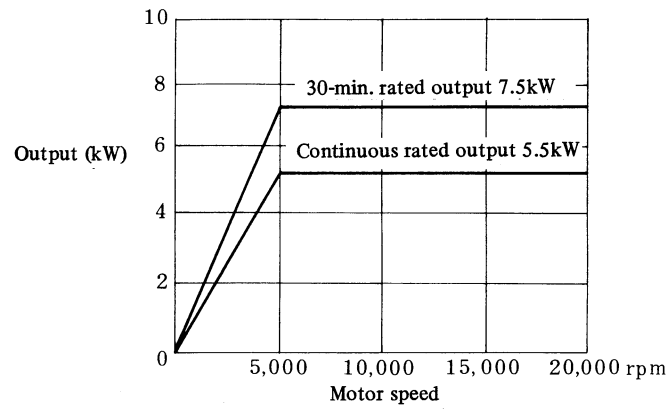

2) Model 8VH

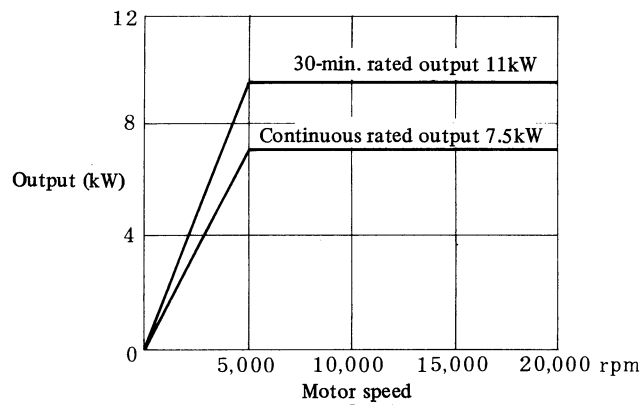

3) Model 12VH

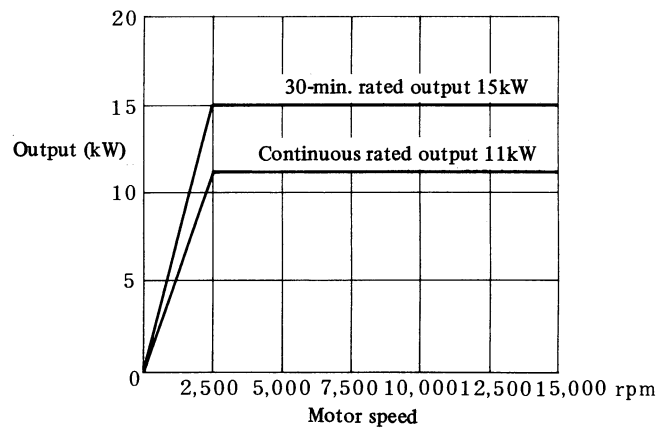

4. ORDER SPECIFICATION DRAWING NUMBER

4.1 AC Spindle Motor

Name		Spec. DWG. No.	Remarks
Model 6VH	Flange mounting	A06B-1056-B308	No key, 20,000 rpm
Model 8VH	Flange mounting	A06B-1058-B308	No key, 20,000 rpm
	Flange mounting	A06B-1058-B398	Same as above, built-in sensor included (512 p/rev)
Model 12VH	Flange mounting	A06B-1062-B308	No key, 15,000 rpm
	Flange mounting	A06B-1062-B398	Same as above, built-in sensor included (512 p/rev)

4.2 AC Spindle Servo Unit

Amp Name	Spec. DWG. No.	Remarks
For model 6VH (*2)	A06B-6055-H208#H534	External radiation type
	A06B-6055-H108#H534	Internal ventilation type
For model 8VH	A06B-6059-H212#H544	External radiation type
For model 12VH	A06B-6059-H215#H545	External radiation type

(*1) For options for the AC SPINDLE SERVO UNIT for Models 8VH and 12VH, refer to Part II, AC SPINDLE SERVO UNIT S SERIES.

(*2) For options for the AC SPINDLE SERVO UNIT for Model 6VH, refer to B-53422E/10 and following sections in the FANUC AC SPINDLE MOTOR Series Specification Manual.

5. OUTER DIMENSIONS

5.1 AC Spindle Motor

5.1.1 Model 6VH (liquid cooling type)

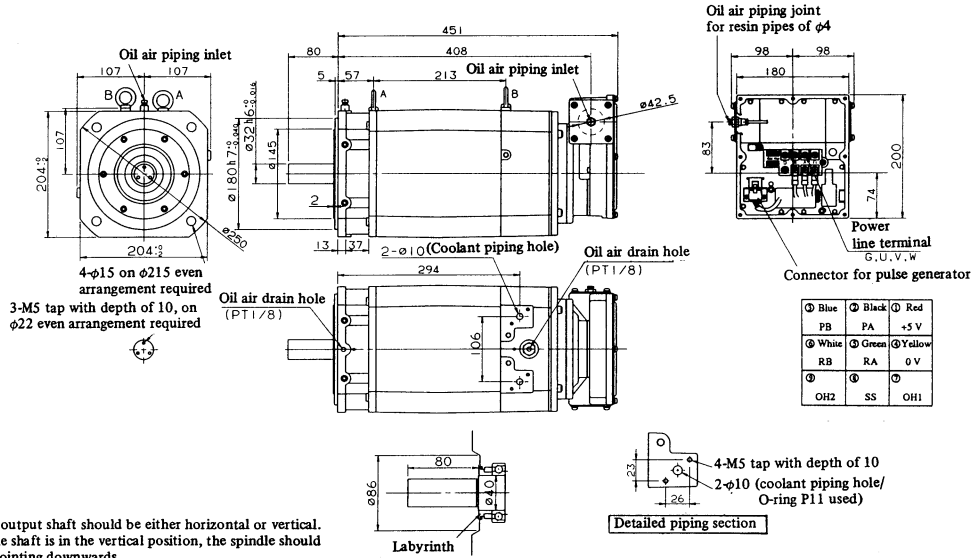

5.1.2 Model 8VH (liquid cooling type)

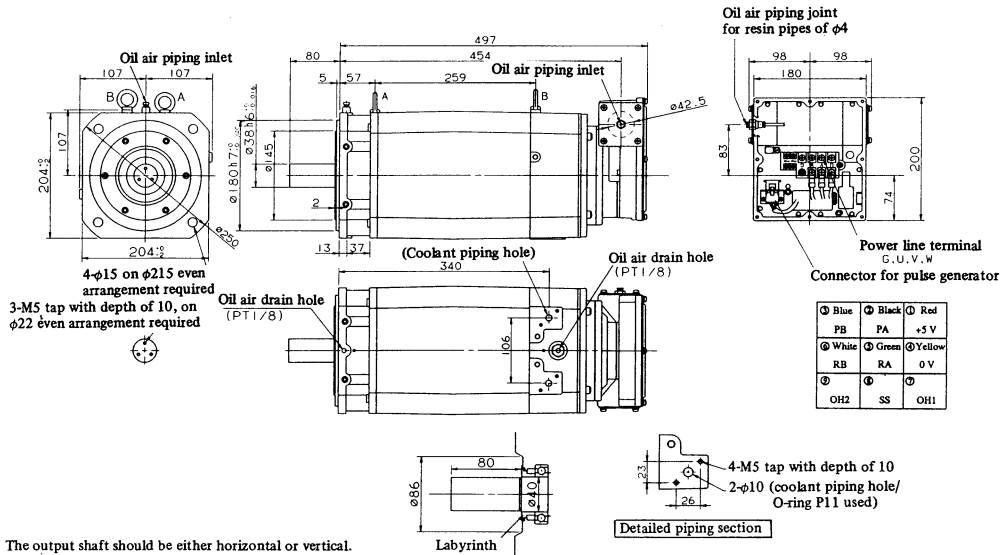

5.1.3 Model 12VH (liquid cooling type)

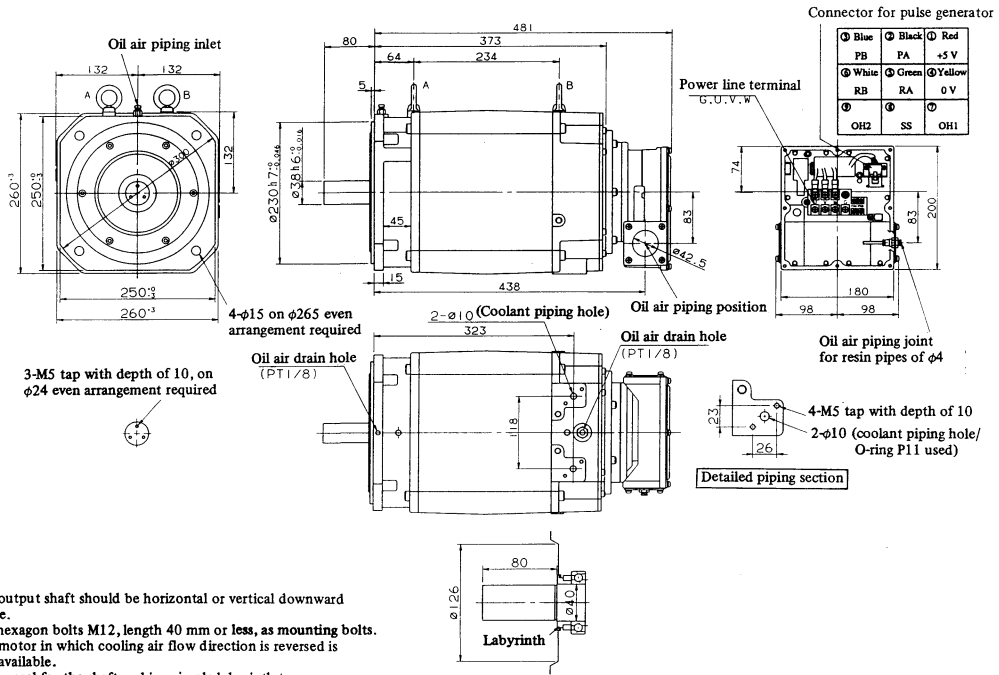

- Note)
1. The output shaft should be horizontal or vertical downward in use.
 2. Use hexagon bolts M12, length 40 mm or less, as mounting bolts.
 3. The motor in which cooling air flow direction is reversed is also available.
 4. As the seal for the shaft end is a simple labyrinth type, take care so that the surface of the flange may not be splashed directly with lubricating oil or the like.

V. SPINDLE ORIENTATION

1. GENERAL

Unlike conventional mechanical spindle orientation using stoppers, etc., the spindle orientation stops the spindle at a fixed position by directly feeding back position signals from the position coder or magnetic sensor directly connected to the machine spindle.

2. FEATURES

- 1) Mechanical parts are not required.
This orientation is accomplished simply by connecting the position coder or magnetic sensor to the spindle without any need of mechanical orientation mechanism (stoppers, pins, etc.) for spindle orientation.
- 2) Reduction of orientation time
Since the spindle motor connected to the spindle is utilized and the orientation can be done directly from high-speed rotation, irrespective of gear shift, the orientation time is largely reduced.
- 3) Simplified power magnetic sequence control
This sequence consists of the spindle orientation command, its completion signal, spindle high/low speed signal and spindle medium speed signal only without any need of other signals. Neither orientation speed command sequence nor torque limit command sequence is needed.
- 4) Low price
This simplified orientation control circuit designed for the spindle orientation only is simplified and low-priced.
- 5) High reliability
Electrical system assures improved reliability without any damage to the mechanical section against an external impact.
- 6) High accuracy and rigidity
The spindle orientation accuracy and rigidity are enough to execute automatic tools exchange (ATC).
- 7) Positioning of workpiece
Workpieces can be positioned to arrange their loading and unloading directions in lathe.
- 8) Reduction of the number of processes in boring
Since the spindle orientation can be done in the same direction as the rotating direction of the spindle when boring ends, workpieces will not be damaged by tool blades.
Since these tool blades can be mounted or dismounted in a fixed direction with reference to workpieces, programming is easy.

3. CONFIGURATION AND ORDER SPECIFICATION

3.1 Position Coder Type (Stop Position Internal Setting)

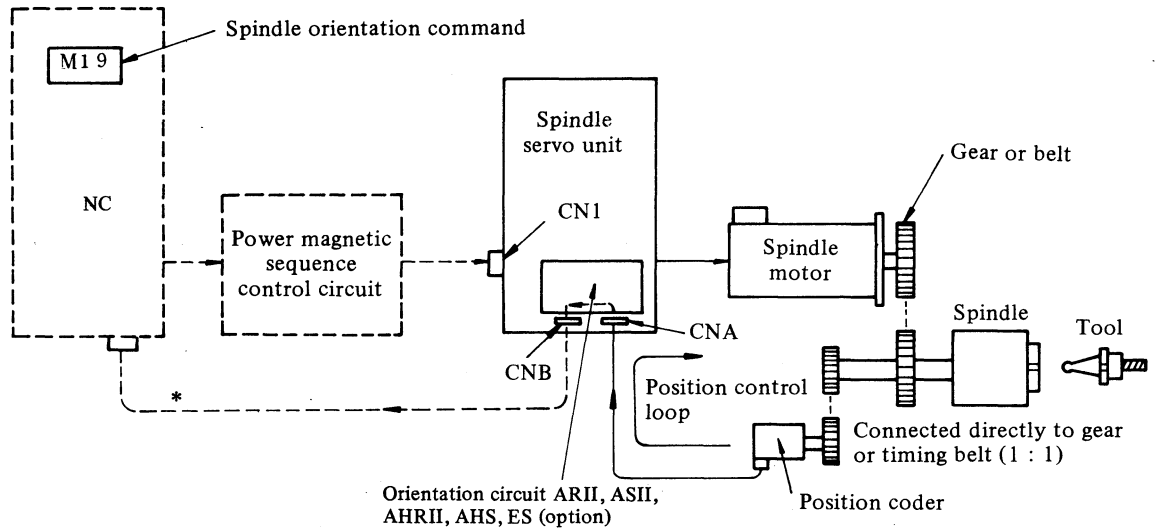

3.2 Position Coder Type (Stop Position External Command)

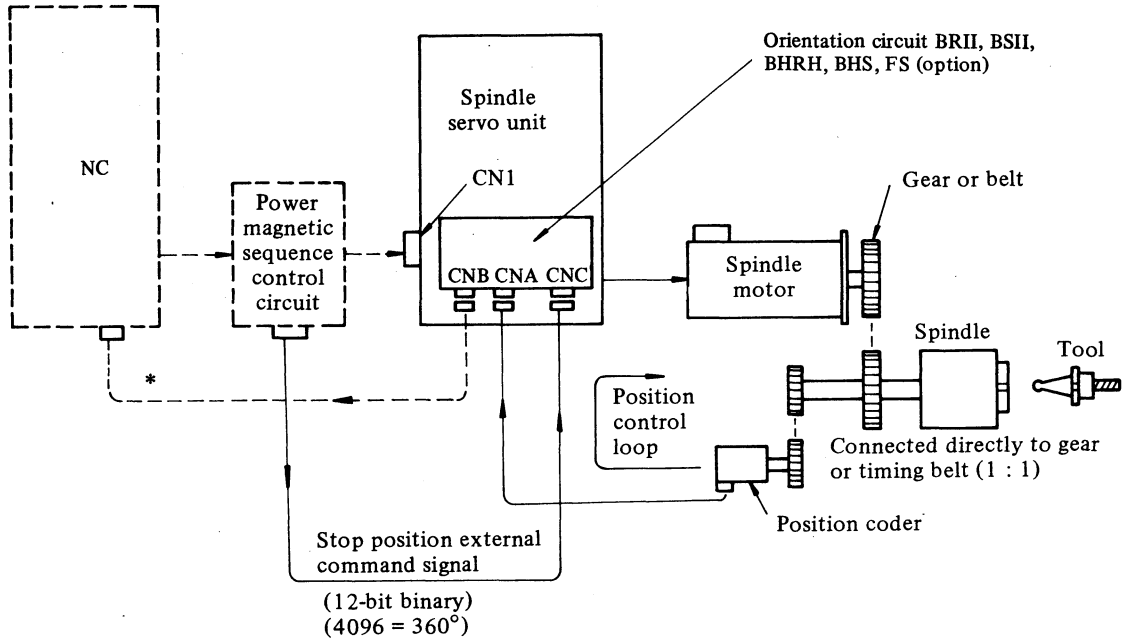

Note 1) When a position coder is attached to lathe, etc., it can be used for this purpose.

Note 2) The broken line marked with * is the cable route when the position coder attached to lathe or the position coder for the synchronous feed for machining center is used concurrently.

Note 3) When a built-in sensor signal conversion circuit is used, refer to the items related to built-in sensor conversion circuits in Part VII.

3.3 Magnetic Sensor Type

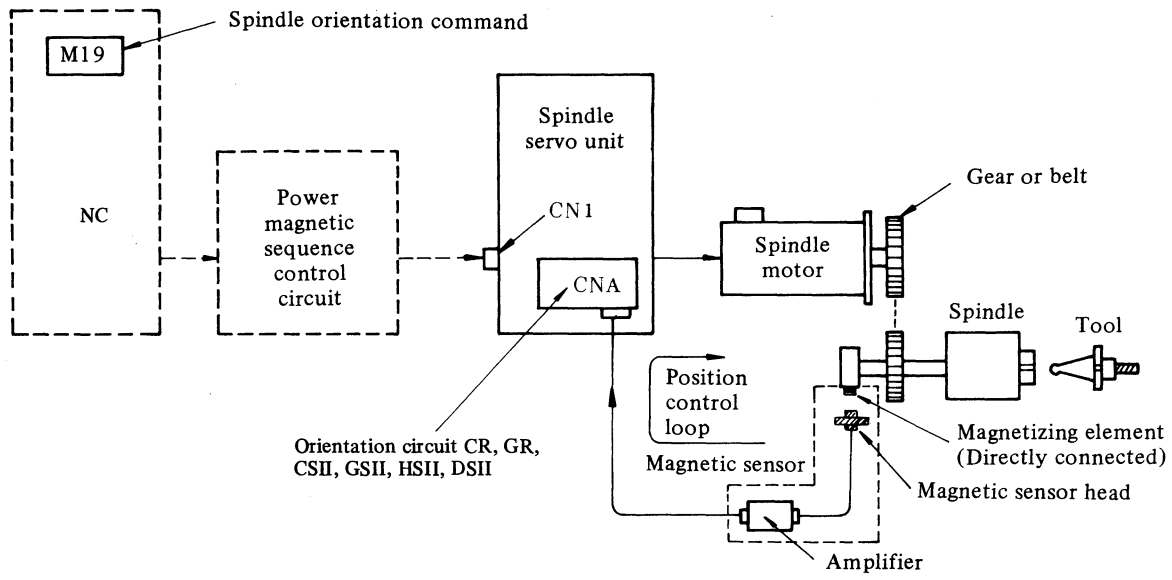

3.4 Order Specification Drawing Number

3.4.1 For models 1S — 3S

Classi- fica- tion	Name	Spec. DWG. No.	PCB DWG. No.	Remarks
Option	Orienta- tion ARII	A06B-6059-J110	A20B-0008-0242	Position coder system Two-speed variable, stop position internal setting type Spindle speed of 8000 rpm or less
	Orienta- tion BRII	A06B-6059-J111	A20B-0008-0243	Position coder system Two-speed variable, stop position externally commanded type Spindle speed of 8000 rpm or less
	Orienta- tion AHRII	A06B-6059-J112	A20B-0008-0244	Position coder system Two-speed variable, stop position internal setting type Spindle speed of 20000 rpm or less
	Orienta- tion BHRII	A06B-6059-J113	A20B-0008-0245	Position coder system Two-speed variable, stop position externally commanded type Spindle speed of 20000 rpm or less
	Orienta- tion CR	A06B-6059-J120	A16B-1300-0110	Magnetic sensor system, two-speed variable Spindle speed of 8000 rpm or less
	Orienta- tion GR	A06B-6059-J121	A16B-1300-0111	Magnetic sensor system, two-speed variable Spindle speed of 12000 rpm or less

Classification	Name	Spec. DWG. No.	PCB DWG. No.	Remarks
Option	Position coder C	A86L-0027-0001#101	—	Balanced transmission type, □160 with flange 4000 rpm specification
	Position coder D	A86L-0027-0001#001	—	Balanced transmission type, □160 with flange 6000 rpm specification
	Position coder G	A86L-0027-0001#201	—	Balanced transmission type, □160 with flange 8000 rpm specification
	Position coder J	A86L-0027-0001#102	—	Balanced transmission type, □68 with flange 4000 rpm specification
	Position coder K	A86L-0027-0001#002	—	Balanced transmission type, □68 with flange 6000 rpm specification
	Position coder L	A86L-0027-0001#202	—	Balanced transmission type, □68 with flange 8000 rpm specification
	Position coder E	A86L-0027-0001#103	—	Balanced transmission type, no flange 4000 rpm specification
	Position coder F	A86L-0027-0001#003	—	Balanced transmission type, no flange 6000 rpm specification
	Position coder H	A86L-0027-0001#203	—	Balanced transmission type, no flange 8000 rpm specification

Classi- fica- tion	Name	Spec. DWG. No.	PCB DWG. No.	Remarks
Option	Magnetic sensor N	A57L-0001-0037/N	—	Spindle speed of 12000 rpm or less
	Magnetic sensor P	A57L-0001-0037/P	—	Spindle speed of 12000 rpm or less Small type
	Magnetic sensor Q	A57L-0001-0037/Q	—	ID of $\phi 40$, cylindrical, high-speed type Spindle speed of 20000 rpm or less
	Magnetic sensor R	A57L-0001-0037/R	—	ID of $\phi 50$, cylindrical, high-speed type Spindle speed of 20000 rpm or less
	Magnetic sensor S	A57L-0001-0037/S	—	ID of $\phi 60$, cylindrical, high-speed type Spindle speed of 15000 rpm or less
	Magnetic sensor T	A57L-0001-0037/T	—	ID of $\phi 70$, cylindrical, high-speed type Spindle speed of 15000 rpm or less

3.4.2 For models 6S — 22S

Classi- fica- tion	Name	Spec. DWG. No.	PCB DWG. No.	Remarks
Option	Orienta- tion ASII	A06B-6059-J130	A20B-0008-0242	Position coder system Two-speed variable, stop position internal setting type Spindle speed of 8000 rpm or less
	Orienta- tion BSII	A06B-6059-J131	A20B-0008-0243	Position coder system Two-speed variable, stop position externally commanded type Spindle speed of 8000 rpm or less
	Orienta- tion AHS	A06B-6059-J132	A20B-0008-0244	Position coder system Two-speed variable, stop position internal setting type Spindle speed of 20000 rpm or less

Classification	Name	Spec. DWG. No.	PCB DWG. No.	Remarks
Option	Orientation BHS	A06B-6059-J133	A20B-0008-0245	Position coder system Two-speed variable, stop position externally commanded type Spindle speed of 20000 rpm or less
	Orientation ES	A06B-6059-J134	A20B-1000-0462	Position coder system Four-speed variable, stop position internal setting type Spindle speed of 8000 rpm or less
	Orientation FS	A06B-6059-J135	A20B-1000-0463	Position coder system Four-speed variable, stop position externally commanded type Spindle speed of 8000 rpm or less
	Orientation CSII	A06B-6059-J140	A20B-0008-0032	Magnetic sensor system, two-speed variable Spindle speed of 8000 rpm or less
	Orientation GSII	A06B-6059-J141	A20B-0008-0033	Magnetic sensor system, two-speed variable Spindle speed of 12000 rpm or less
	Orientation DSII	A06B-6059-J142	A20B-0009-0521	Magnetic sensor system, three-speed variable Spindle speed of 8000 rpm or less
	Orientation HSII	A06B-6059-J143	A20B-0008-0033 + A06R-6044-J948	Magnetic sensor system, two-speed variable Spindle speed of 20000 rpm or less

For the specifications for position coders and magnetic sensors, refer to Subsection 3.4.1.

3.4.3 Built-in sensor signal conversion circuit

When the built-in sensor signal conversion circuit is used as a position coder, refer to the section related to built-in sensor signal conversion circuit in Part VII.

4. SPECIFICATIONS

4.1 Type

Name	System	Explanation	Purpose
Orienta- tion ARII, ASII	Two-speed variable Position coder system Stop position internal setting type	Stops only at one point during one rotation of the spindle, which is set freely inside the PCB.	<ul style="list-style-type: none"> . For lathe type spindle positioning (loading/ unloading works, etc.) . Machining center type spindle orientation . Machine tools with spindles of two speeds or less . Spindle speed of 8000 rpm or less
Orienta- tion BRII, BSII	Two-speed variable Position coder system Stop position externally commanded type	Can move the stop position set in advance inside the PCB to any one point during one rotation of the spindle by inputting a 12-bit signal from the outside.	<ul style="list-style-type: none"> . For lathe type spindle positioning (For indexing the spindle of a turning center, etc. However, mechanically locking is needed while cutting.) Can be used for positioning when arranging the mounting/dismounting directions of workpieces using a robot. . Machine tools with spindles of two speeds or less . Spindle speed of 8000 rpm or less
Orienta- tion AHRII, AHS	Two-speed variable, high-speed type Position coder system Stop position internal setting type	Stops only at one point during one rotation of the spindle, which is set freely inside the PCB.	<ul style="list-style-type: none"> . For lathe type spindle positioning (loading/ unloading works, etc.) . Machining center type spindle orientation . Machine tools with spindles of two speeds or less . Spindle speed of 20000 rpm or less
Orienta- tion BHRII, BHS	Two-speed variable, high-speed type Position coder system Stop position externally commanded type	Can move the stop position set in advance inside the PCB to any one point during one rotation of the spindle by inputting a 12-bit signal from the outside.	<ul style="list-style-type: none"> . For lathe type spindle positioning (For indexing the spindle of a turning center, etc. However, mechanically locking is needed while cutting.) Can be used for positioning when arranging the mounting/dismounting directions of workpieces using a robot. . Machine tools with spindles of two speeds or less . Spindle speed of 20000 rpm or less

Name	System	Explanation	Purpose
Orientation ES	Four-speed variable Position coder system Stop position internal setting type	Stops only at one point during one rotation of the spindle, which is set freely inside the PCB.	<ul style="list-style-type: none"> . For lathe type spindle positioning (loading/unloading works, etc.) . Machining center type spindle orientation . Machine tools with spindles of four speeds or less . Spindle speed of 8000 rpm or less
Orientation FS	Position coder system Stop position internal setting type	Can move the stop position set in advance inside the PCB to any one point during one rotation of the spindle by inputting a 12-bit signal from the outside.	<ul style="list-style-type: none"> . For lathe type spindle positioning (For indexing the spindle of a turning center, etc. However, mechanically locking is needed while cutting.) Can be used for positioning when arranging the mounting/dismounting directions of workpieces using a robot. . Machine tools with spindles of four speeds or less . Spindle speed of 8000 rpm or less
Orientation CR, CSII	Magnetic sensor system	Can stop at a specified position using a noncontact position detector. Stops at a position where the magnetic generator faces the magnetic sensor.	<ul style="list-style-type: none"> . Machining center type spindle orientation . Machine tools with <u>spindles of two speeds</u> or less . Spindle speed of 8000 rpm or less
Orientation GR, GSII			<ul style="list-style-type: none"> . Machining center type spindle orientation . Machine tools with <u>spindles of two speeds</u> or less . Spindle speed of 12000 rpm or less
Orientation DSII			<ul style="list-style-type: none"> . Machining center type spindle orientation . Machine tools with <u>spindles of three speeds</u> or less . Spindle speed of 8000 rpm or less
Orientation HSII			<ul style="list-style-type: none"> . Machining center type spindle orientation . Machine tools with <u>spindles of two speeds</u> or less . Spindle speed of 20000 rpm or less

4.2 Specifications

4.2.1 Position coder system

No.	Item	Explanation	
		Stop position internal setting	Stop position external setting
1	Position coder	Coupled to the spindle one to one ratio. 1024 pulses/rotation (A-phase and B-phase signals) 1 pulse/rotation (One pulse/rev. signal) Balanced transmission type for 4000 rpm, 6000 rpm, 8000 rpm.	
2	Detection units (Note 1)	One spindle rotation (360°) is divided by 1024 x 4 (4096) pulses, i.e. 0.088° is made one pulse unit (detection unit). $360^\circ/4096 \text{ pulses} = 0.088^\circ/\text{pulse}$	
3	Stop position internal setting	The distance between the setting point indicated by the (Internal) position coder one pulse/rev. signal and the actual stopping point is set for the number of pulse (N) using three digital switches of 4-bits each.	—
4	Repeated positioning accuracy (Note 1)	$\pm 0.2^\circ$ (spindle angle) Machine error factors (for example, the backlash of the coupling between the spindle and position coder) are excluded. Depending on the fineness of the position gain adjustment, the spindle may move for one detection unit (0.088°).	
5	Stop position external setting	—	Position to be stopped can be specified by a 12-bit (4096) contact point signal (M pulse) from the outside. Stops at the position of the number of pulses (M+N) specified from the position of the one rotation signal of the position coder.

No.	Item	Explanation			
		Stop position internal setting		Stop position external setting	
6	Operation	—		When orientation command is given, spindle rotates $\frac{1}{2}$ to $2\frac{1}{2}$ turns after spindle speed has reached orientation speed, and stops at the specified stop position. Incremental positioning is not available.	
7	Orientation circuit		ASII, BSII ARII, BRII	AHS, BHS AHRII, BHRII	ES, FS
	Allowable range of maximum spindle speed (Note 2)	H (High speed)	2000 - 8000 rpm	6000 - 20000 rpm	1500 - 8000 rpm
		MH (Middle high speed)	—	—	500 - 3000 rpm
		ML (Middle low speed)	—	—	250 - 2000 rpm
		L (Low speed)	400 - 2000 rpm	1200 - 6000 rpm	100 - 1000 rpm
8	Allowable range of gear ratio <u>High speed H</u> Low speed L <u>High speed H</u> Middle high speed MH <u>Middle high speed MH</u> Middle low speed ML <u>Middle low speed ML</u> Low speed L	2 - 5	2 - 5	2 - 5	

Note 1) When the built-in sensor signal conversion circuit is used, items 2 "sensing unit" and 4 "repeated positioning accuracy" change depending on the number of the detection gear teeth.

No. of detection gear teeth	Detection unit	Repeat accuracy
256	0.088°	$\pm 0.2^\circ$
128	0.176°	$\pm 0.4^\circ$
64	0.264°	$\pm 0.75^\circ$

Note 2) Make sure to use in the speed range shown above. If the range of the maximum spindle speed goes out of the range shown above in one of high-speed, middle-speed or low-speed gear, orientation takes longer time to cause a practical problem.

4.2.2 Magnetic sensor system

No.	Item	Explanation				
1	Magnetic sensor	See Section 5.3.				
2	Stop position	Position where the center of the sensor head faces the center of the magnetic generator Position where the center of the sensor head faces the stop position reference mark on the magnetic generator The stop position can be adjusted fine in increment of one degree on the circuit.				
3	Repeated positioning accuracy	Within 0.2°. However, those due to machine error factor are omitted such as mounting and the like.				
4	Maximum holding torque during orientation	Continuous rated torque of the AC spindle motor				
5	Recovery range during orientation	$\pm 240^\circ$ from the stop position during orientation				
6	Orientation circuit	CR, CSII	GR, GSII	DSII	HSII	
	Allowable range of maximum spindle speed (Note 1)	H (High speed)	2000 - 8000 rpm	6000 - 12000 rpm	4000 - 8000 rpm	6000 - 20000 rpm
		M (Middle speed)	—	—	1000 - 2000 rpm	—
	L (Low speed)	400 - 2000 rpm	1200 - 6000 rpm	250 - 667 rpm	1200 - 6000 rpm	

No.	Item	Explanation			
7	Allowable range of gear ratio <u>High speed H</u> Low speed L <u>High speed H</u> Middle speed M <u>Middle speed M</u> Low speed L	2 - 5	2 - 5	3 - 4	2 - 5

Note 1) Make sure to use in the speed range shown above. If the range of the maximum spindle speed goes out of the range shown above in one of high-speed, middle-speed or low-speed gear, orientation takes longer time to cause a practical problem.

5. EXTERNAL DIMENSIONS

5.1 Orientation Control PCB

5.1.1 Models 1S — 3S (position coder)

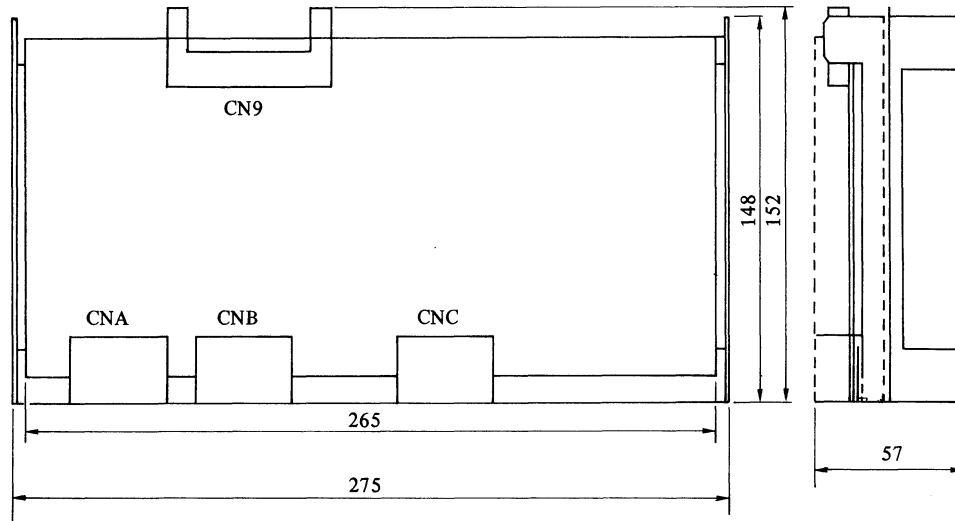

5.1.2 Models 1S — 3S (magnetic sensor)

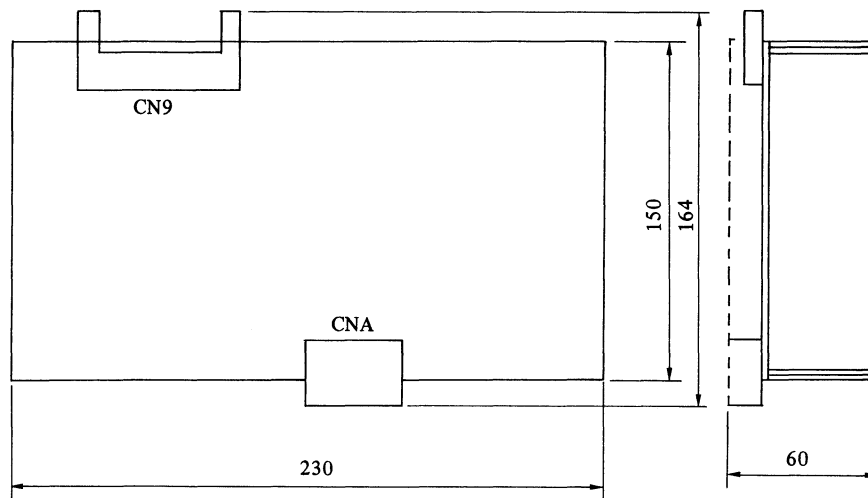

Optional PCB are mounted to the PCB of the AC spindle servo unit before shipment.

5.1.3 Models 6S — 22S

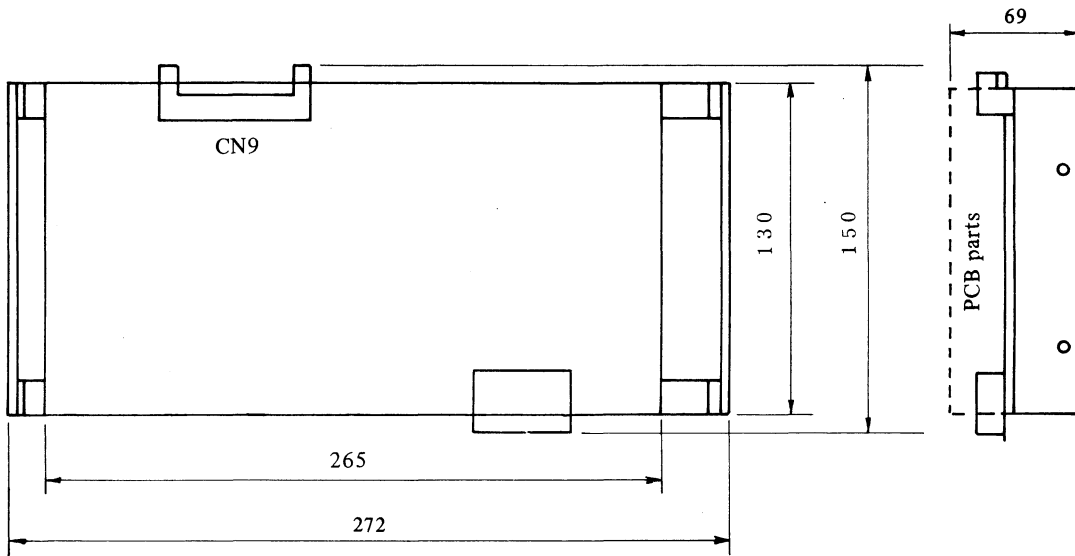

PCB and fixtures have the same sizes in the position coder system and magnetic sensor system.

5.2 Position Coder

5.2.1 Position coder C, D, G (with 160 × 160 flange)

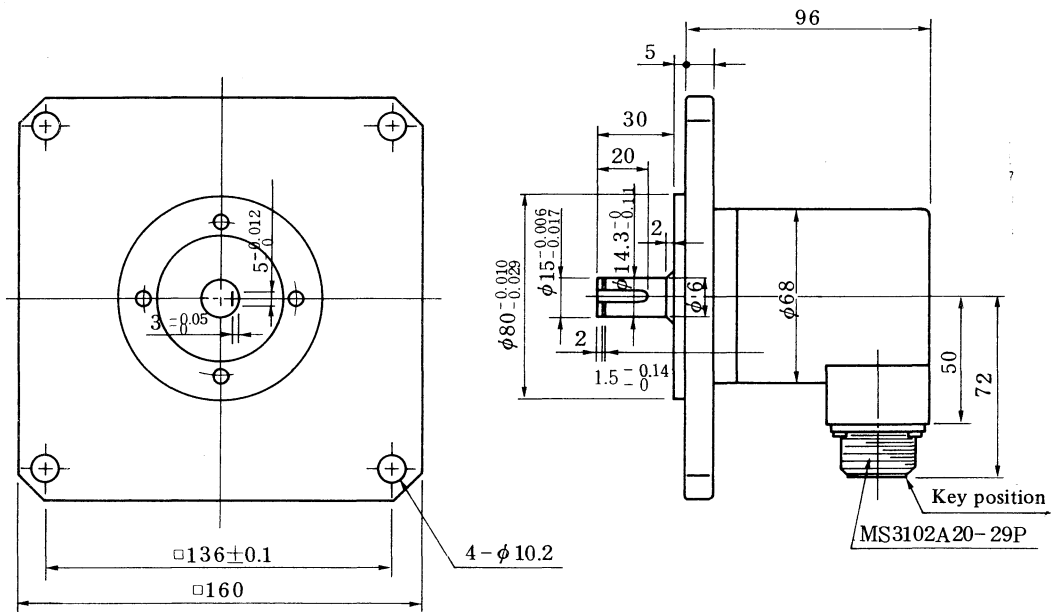

5.2.2 Position coder E, F, H (without flange)

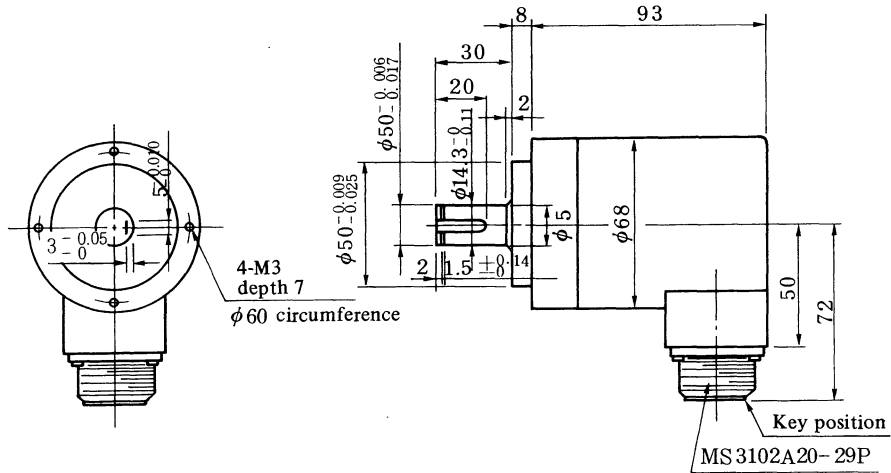

5.2.3 Position coder J, K, L (with 68 x 68 flange)

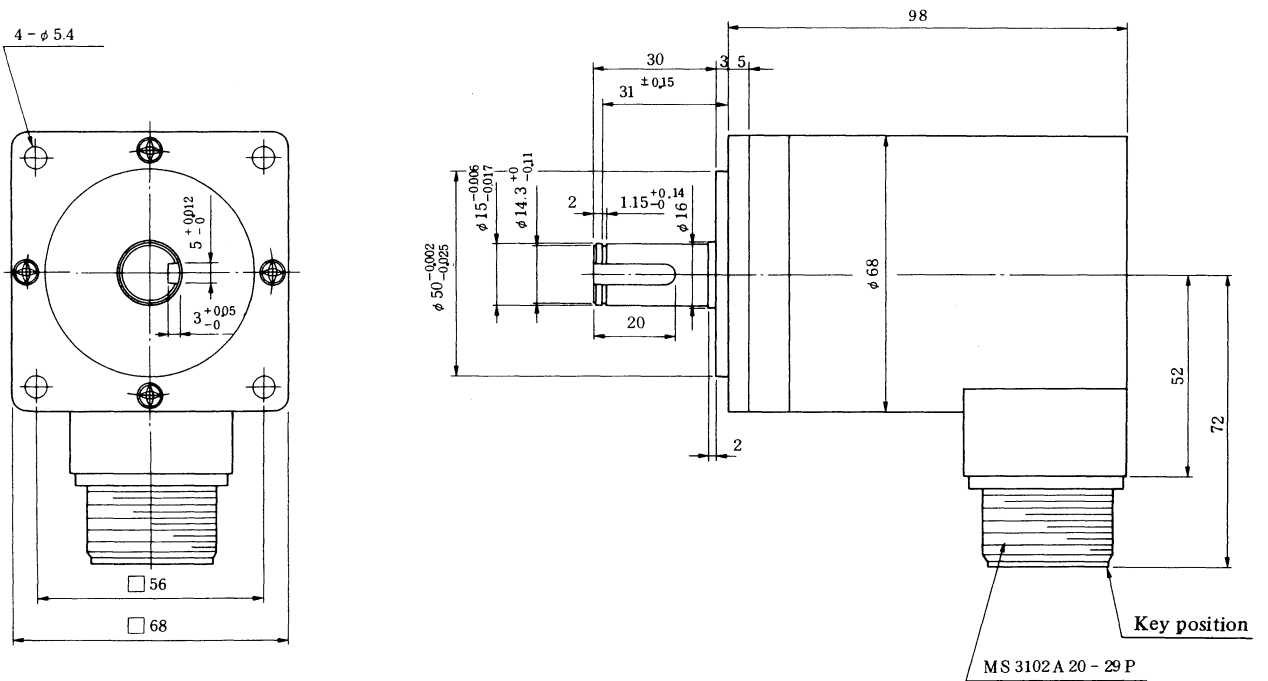

5.3 Magnetic Sensor

5.3.1 Types of magnetic sensor

Items	Unit	Sensor N	Sensor P	Sensor Q	Sensor R	Sensor S	Sensor T
Maximum spindle speed	rpm	12,000		20,000		15,000	
Magnetizing element weight	g	33 <u>+1.5</u>	14.8 <u>+0.7</u>	315 <u>+10</u>	460 <u>+10</u>	770 <u>+15</u>	1000 <u>+15</u>
Allowable centrifugal force (Note 3)	kg	255	130	—————			
Mounting radius from the spindle center to the magnetizing element (Note 3)	mm	40 to 110		20	25	30	35
Gap width from magnetizing element to sensor (Note 1)	mm	1.0 to 2.0					
Deviation between the magnetizing element center and the sensor center (Note 2)	mm	0 to <u>+2.0</u>					
Working temperature range	°C	0 to <u>+50</u>					

Note 1)

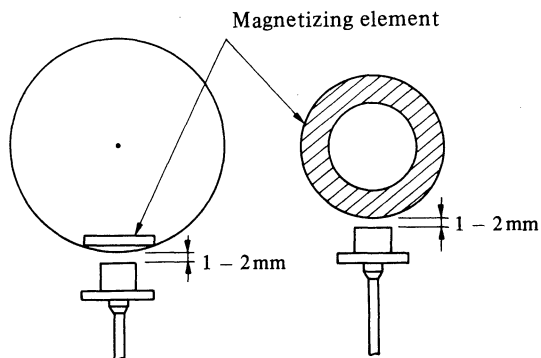

Note 2)

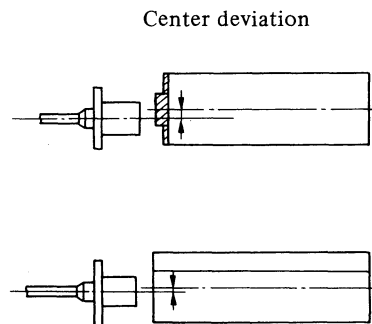

Note 3) When the mounted radius to the magnetizing element is large, maximum revolution is restricted due to allowable centrifugal force.

Note 4) It is recommended to mount the magnetizing element using high-strength bolt.

5.3.2 Magnetizing element

1) External drawing of the magnetizing element for the magnetic sensor N.

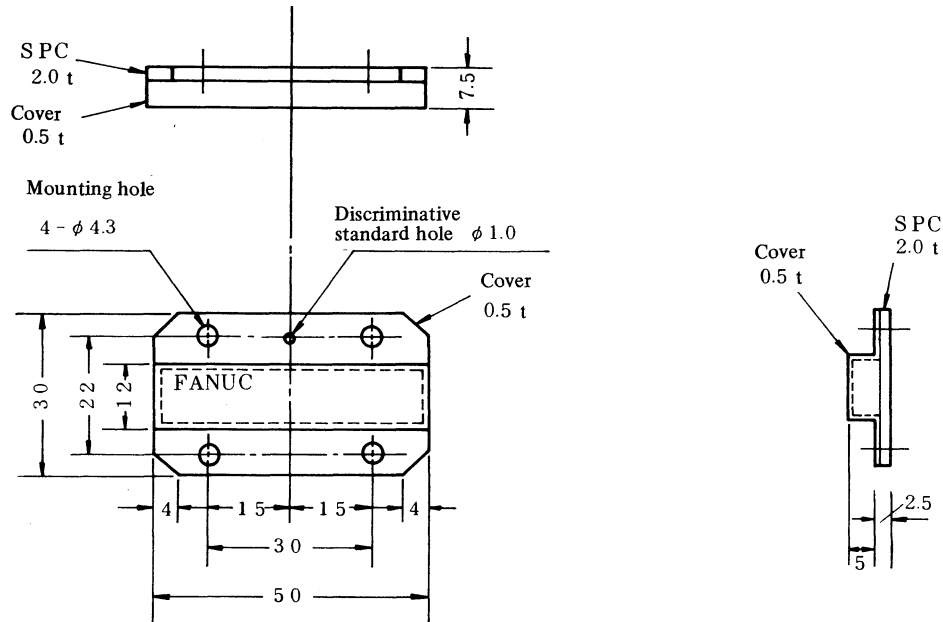

Weight $33 \text{ g} \pm 1.5 \text{ g}$ (Take care in respect of spindle balance)

2) External drawing of the magnetizing element for the magnetic sensor P

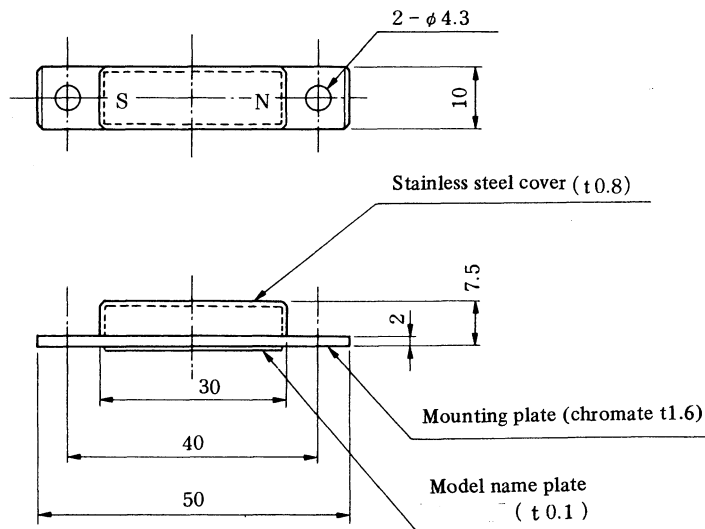

3) External drawing of the magnetizing element for the magnetic sensor Q

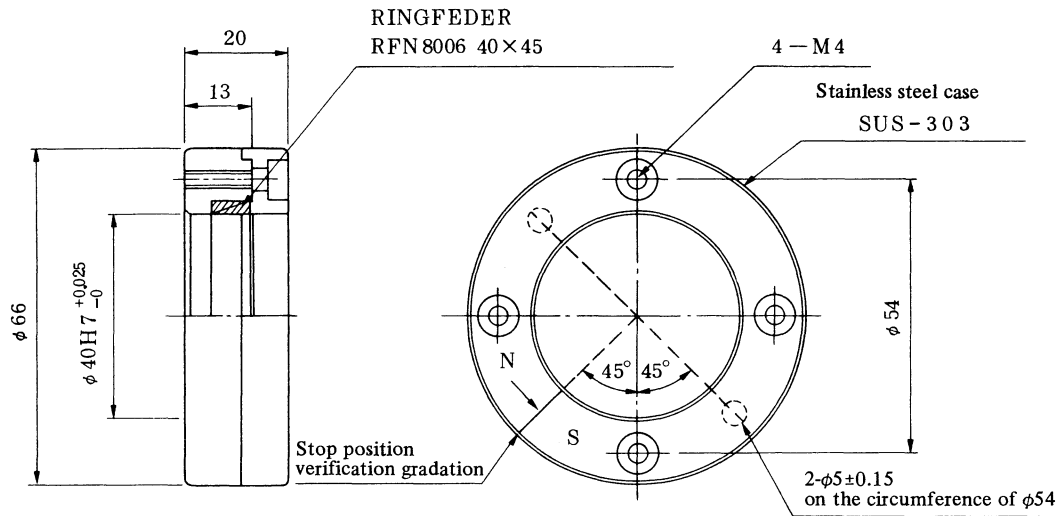

4) External drawing of the magnetizing element for the magnetic sensor R

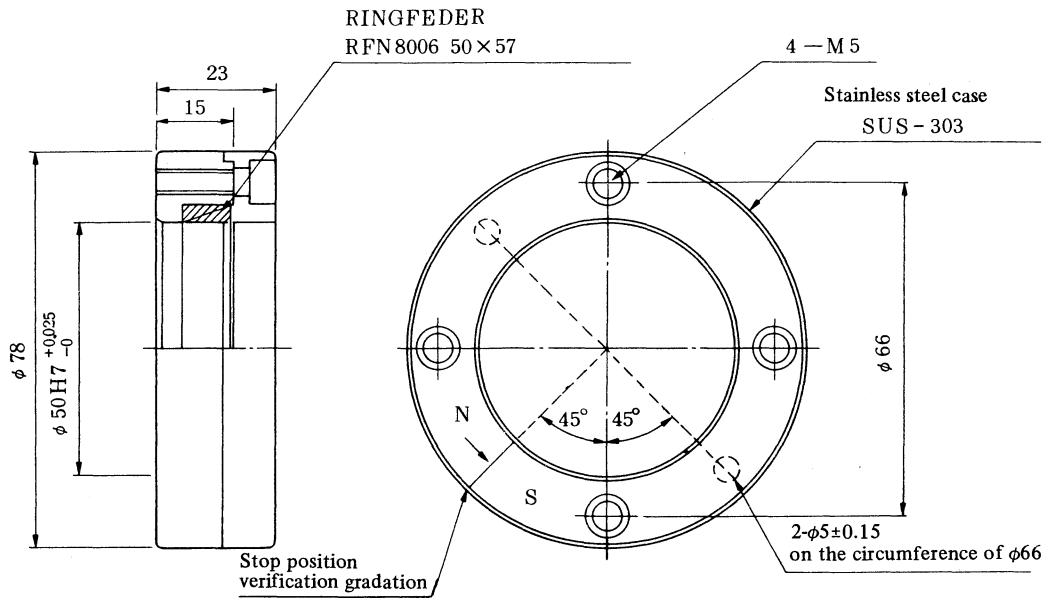

5) External drawing of the magnetizing element for the magnetic sensor S

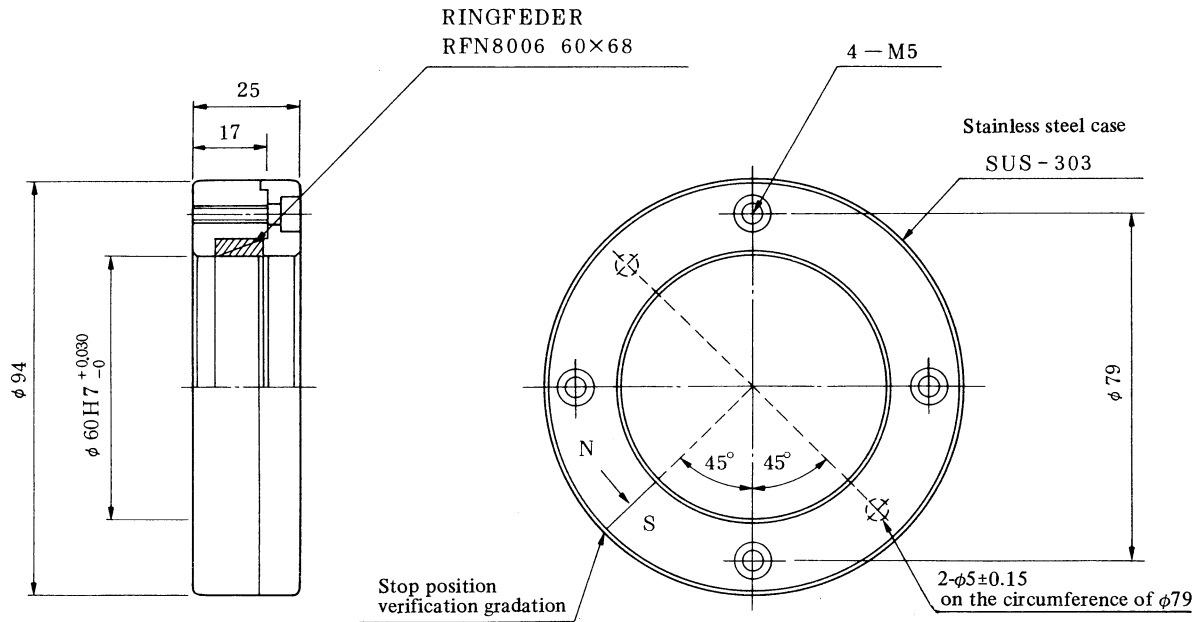

6) External drawing of the magnetizing element for the magnetic sensor T

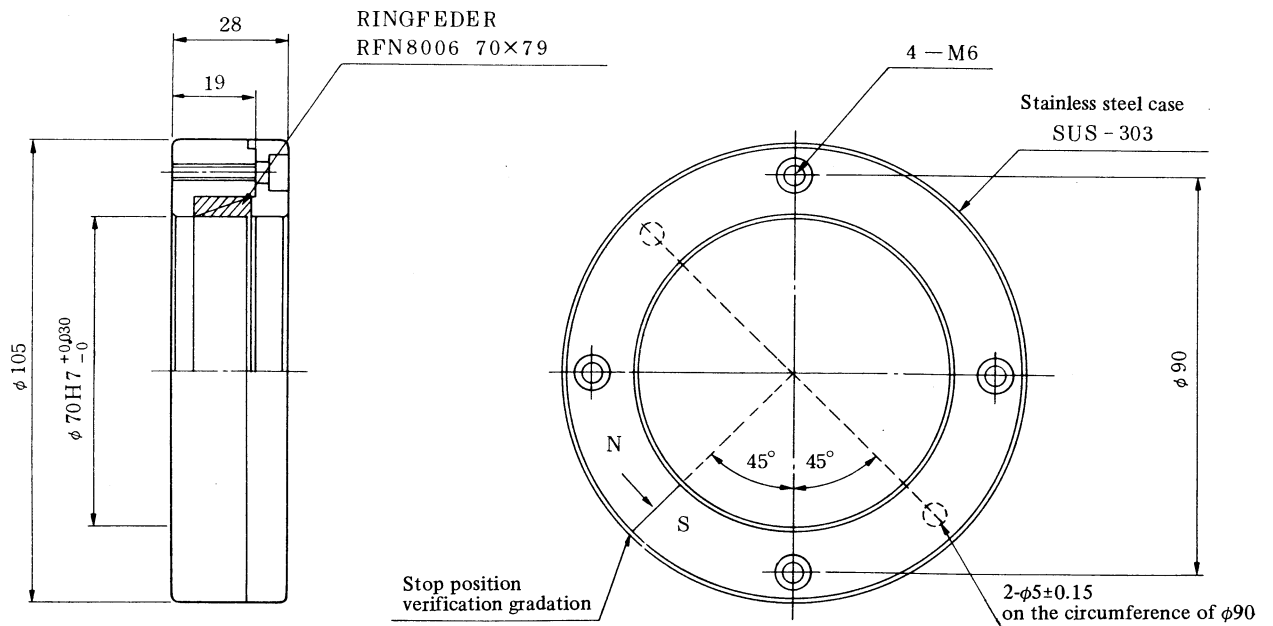

5.3.3 Magnetic sensor

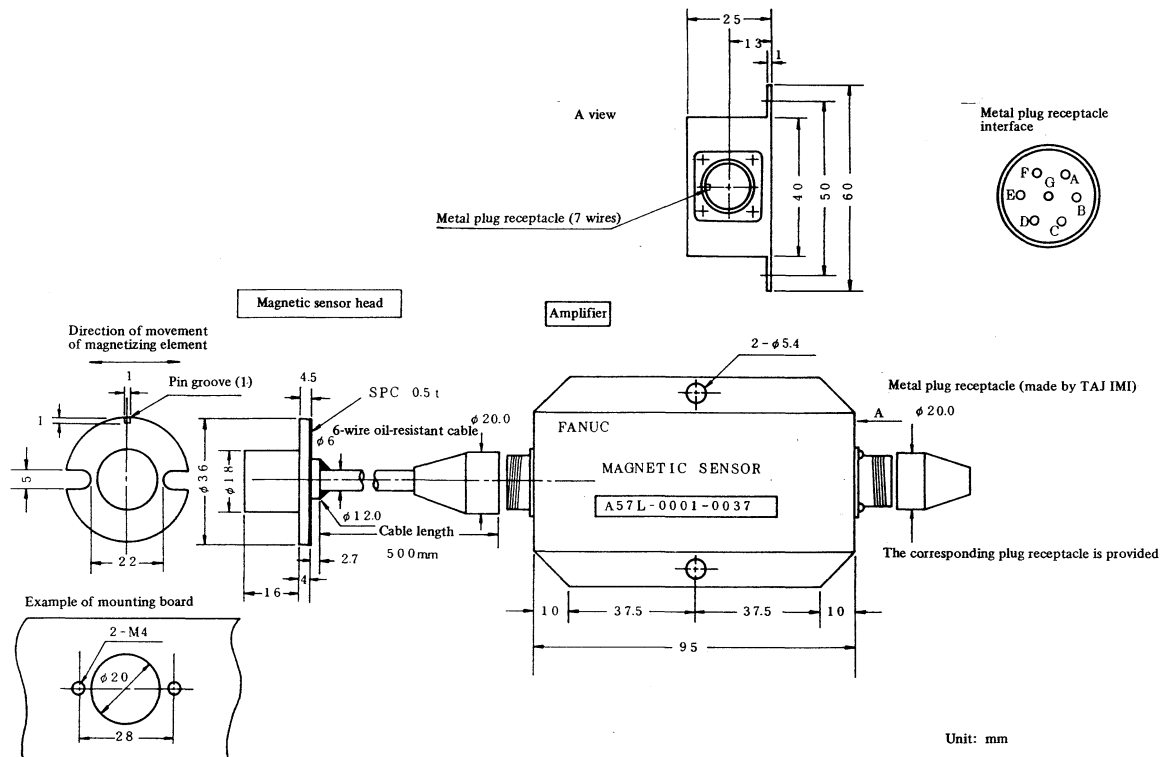

5.3.4 Precautions on use

- 1) As a spann element (RINGFEEDER) is used in the magnetizing element, use 4 bolts to conduct uniform tightening.

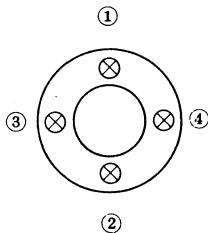

Conduct gradual repeated tightening in the order from ① to ④.

- 2) Relation between the discriminative standard hole and magnet polarity is shown in the diagram below.

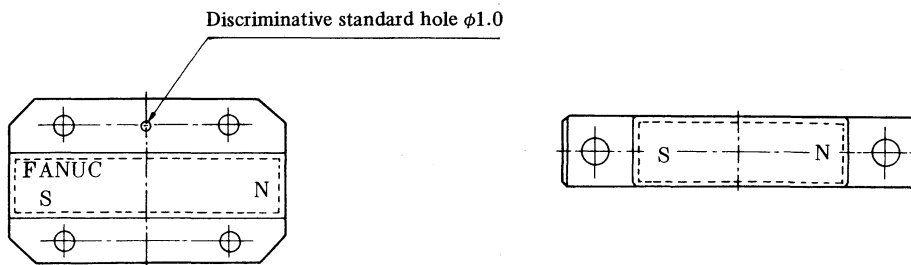

- 3) Use the 2 $\phi 5.0$ holes on the opposite side of the screw clamp of magnetic sensors Q, R, S, and T for the orientation positioning jig.

6. CONNECTION DIAGRAM

6.1 Interface (For position coder)

Models 1S - 3S

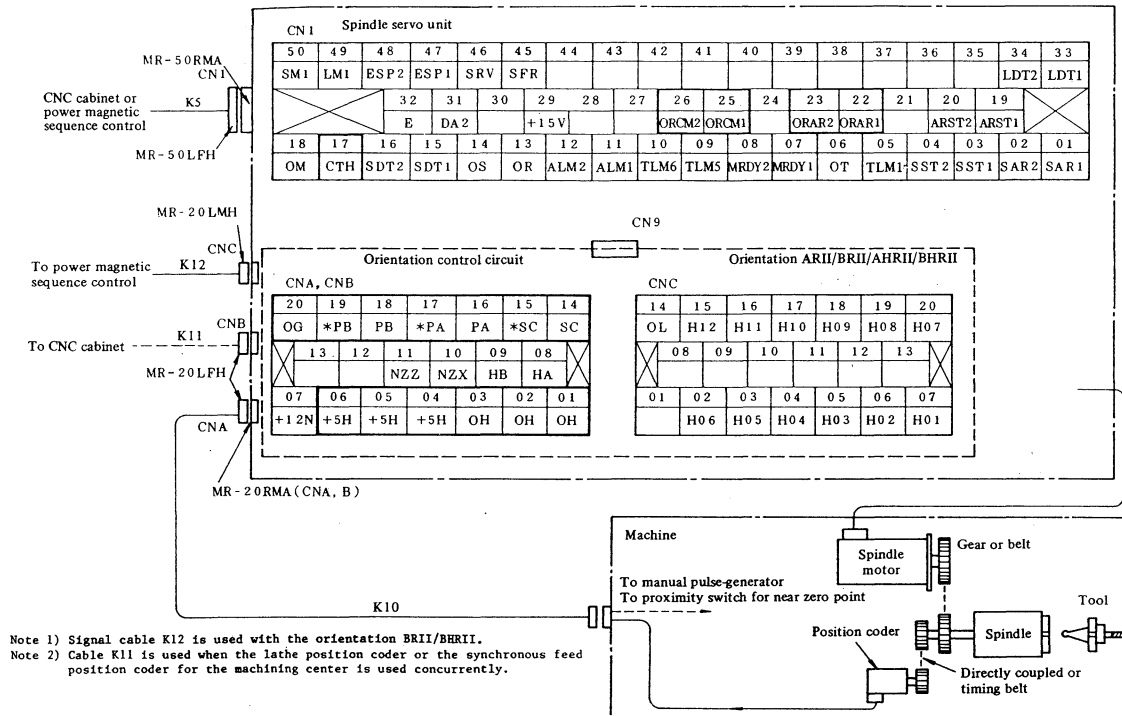

Models 6S - 22S

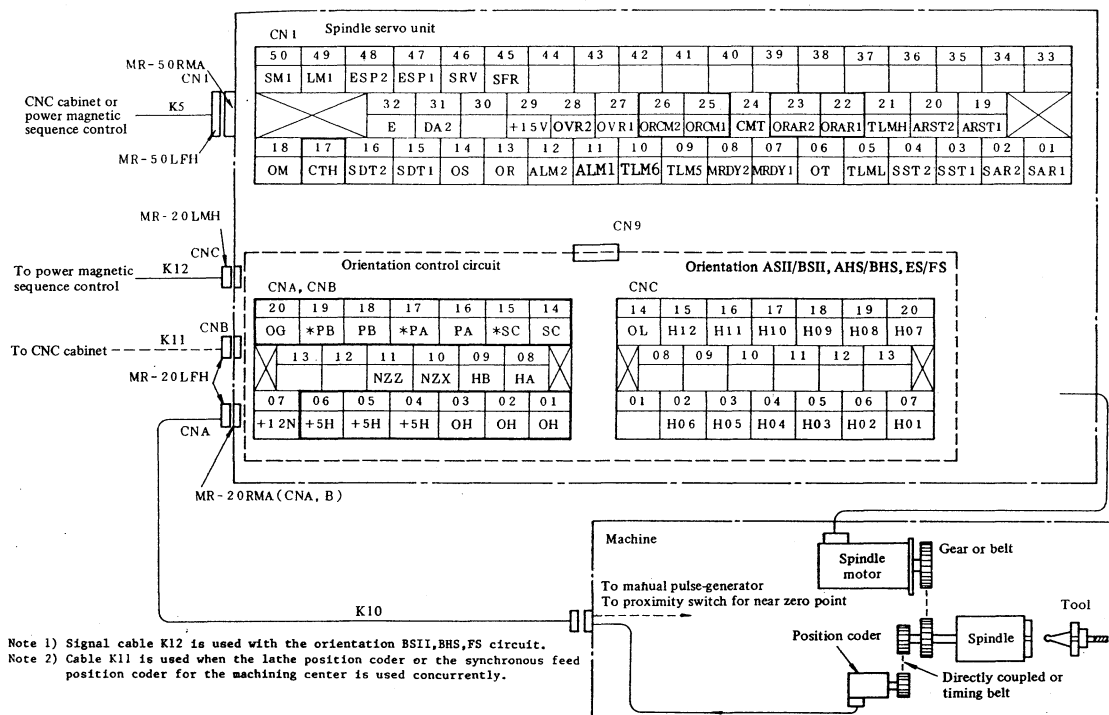

6.1.1 Connection when synchronous feed position coder is concurrently used for lathes and machining centers

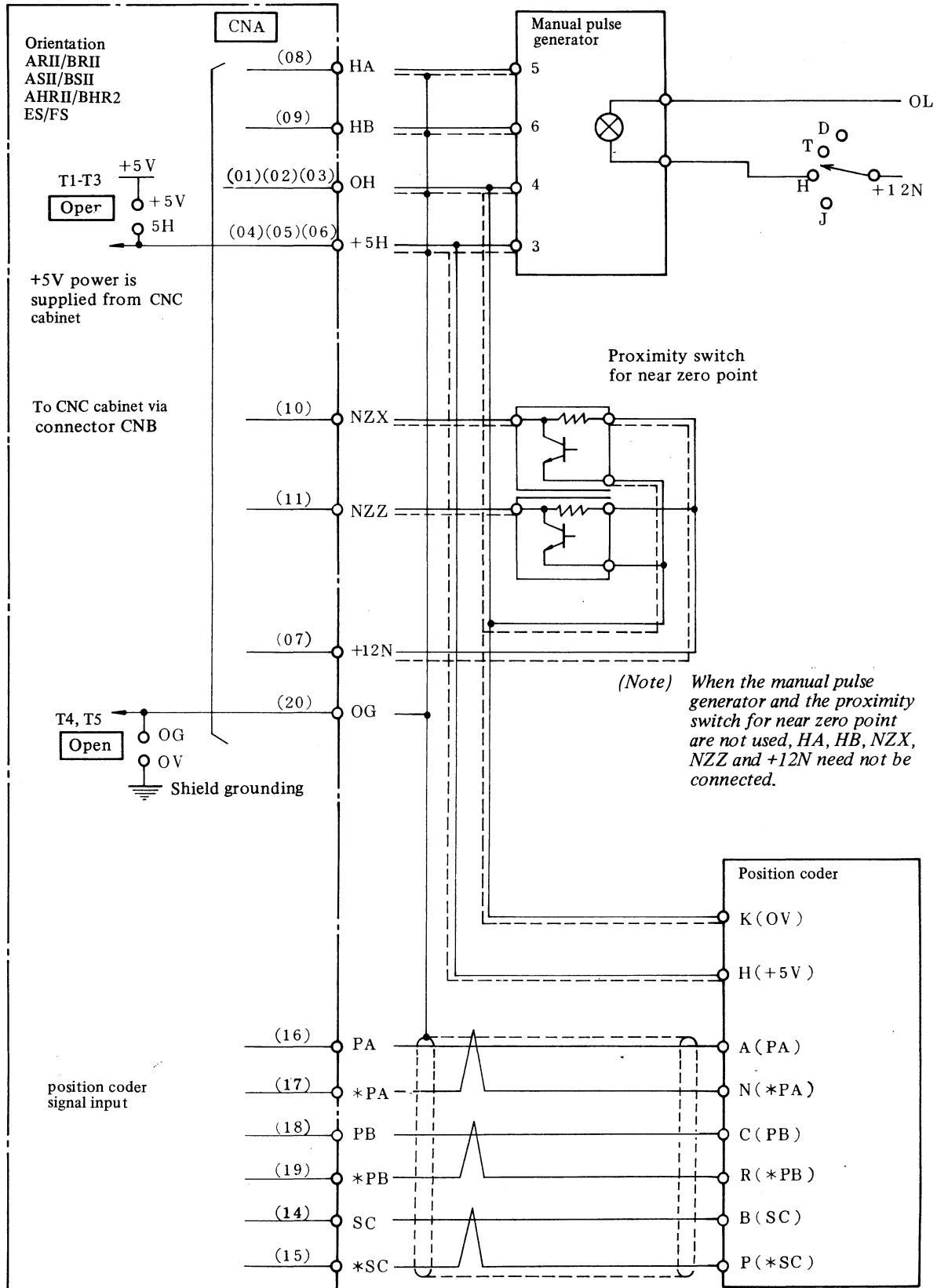

6.1.2 Connection for machining center spindle orientation only (No connection to NC)

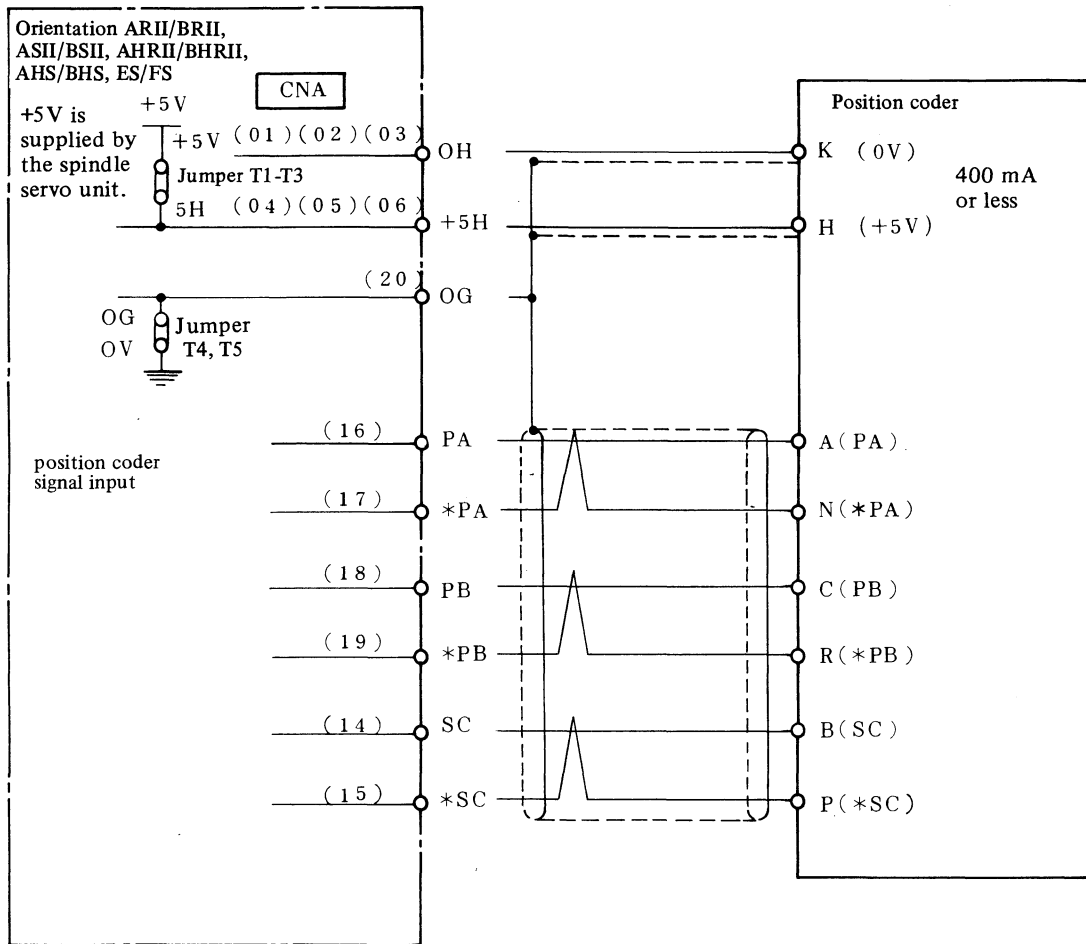

Note) The cable between the AC spindle servo unit and the position coder must not exceed 20 meters.

6.1.3 Stop position external command connection

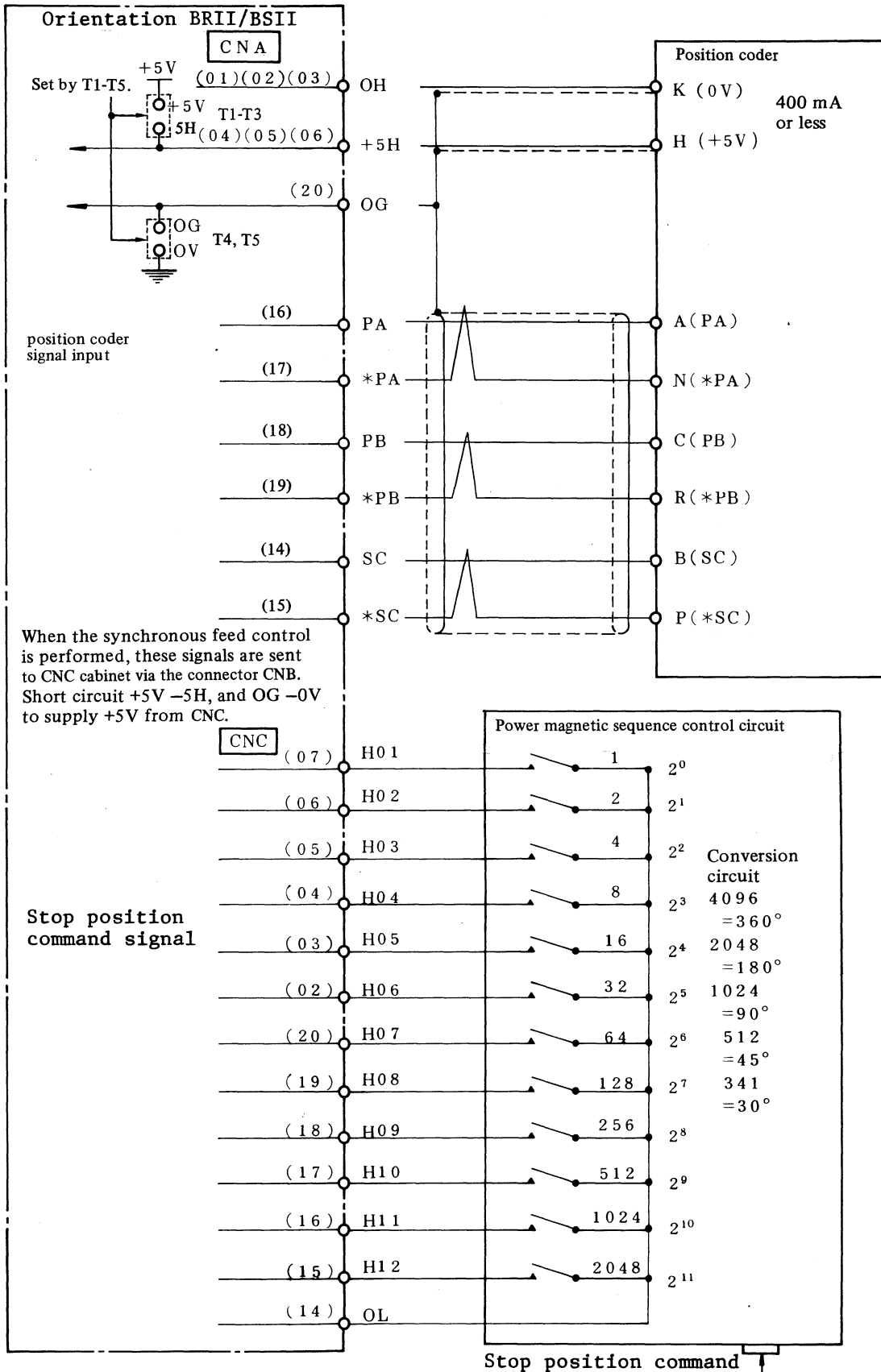

6.2 Interface (For magnetic sensor)

Models 1S - 3S

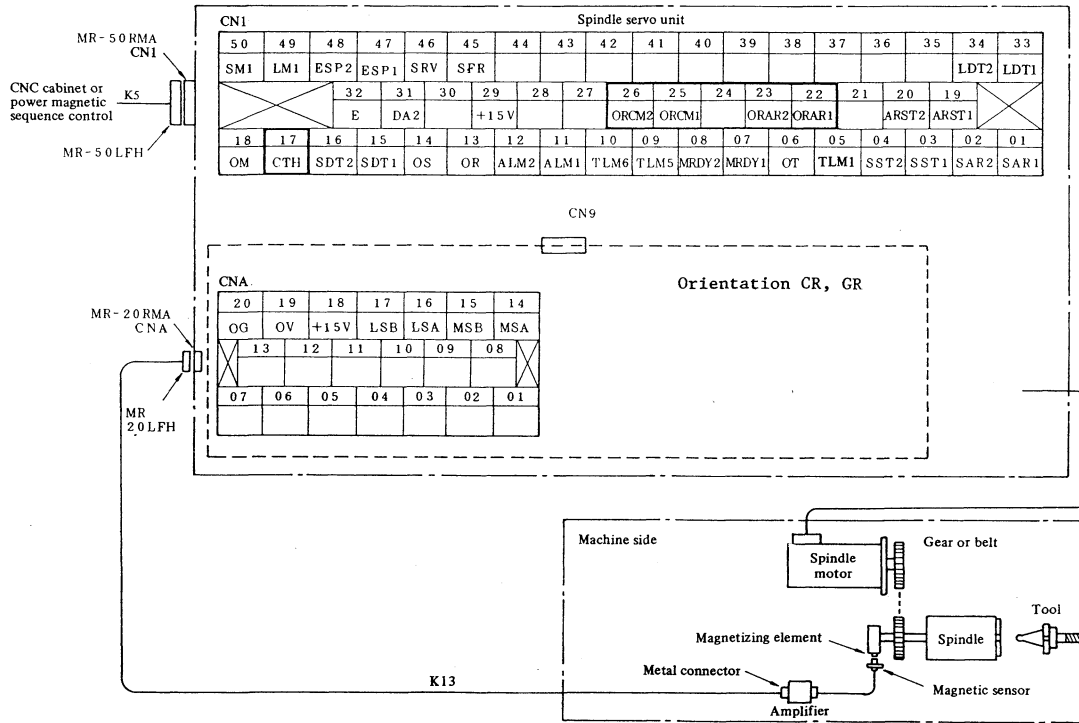

Models 6S - 22S

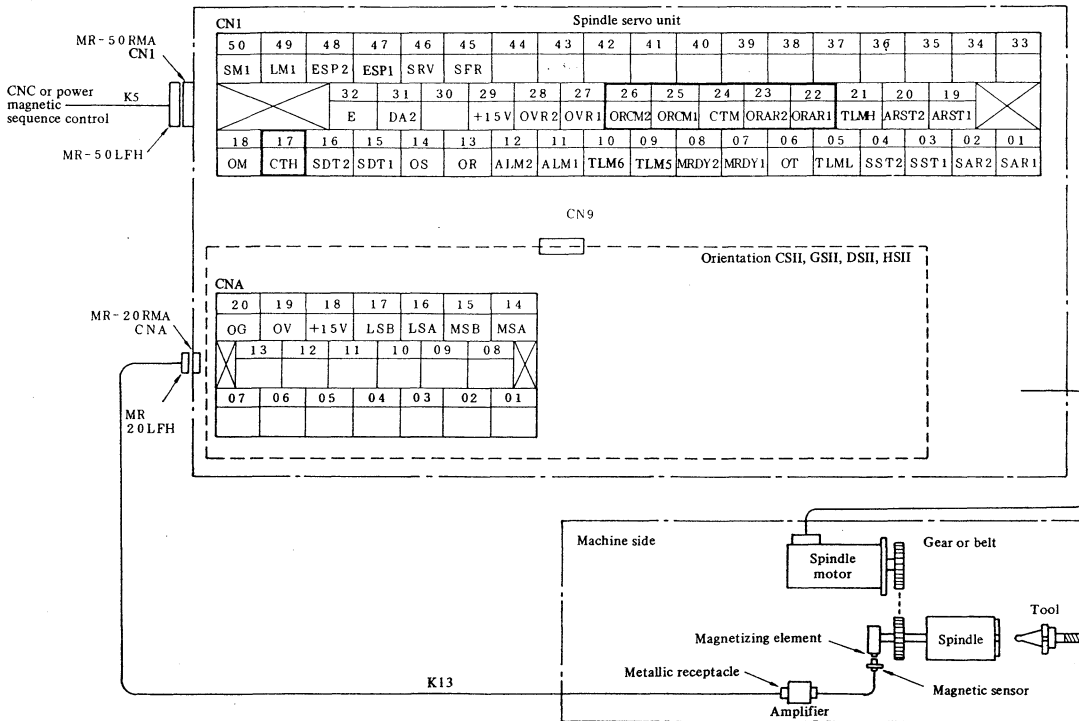

6.2.1 Magnetic sensor connection

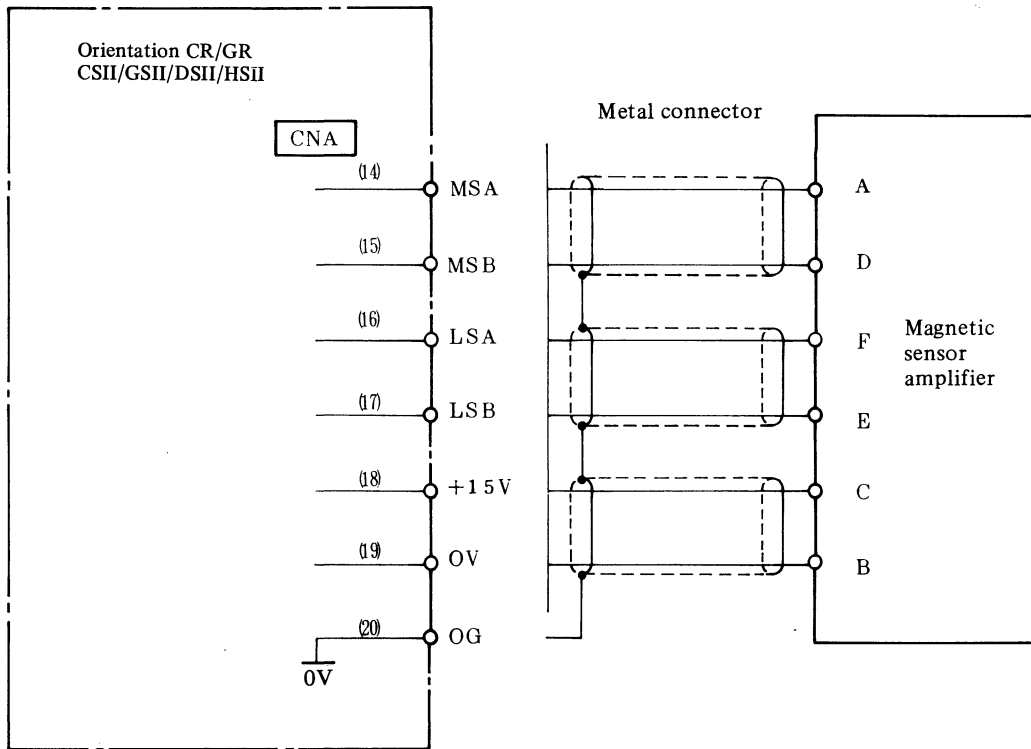

Note) The cable between the AC spindle servo unit and the magnetic sensor amplifier must not exceed 20 meters.

7. INTERFACE SIGNALS

7.1 Description of Signals (up to 2-stage speed change gear spindle)

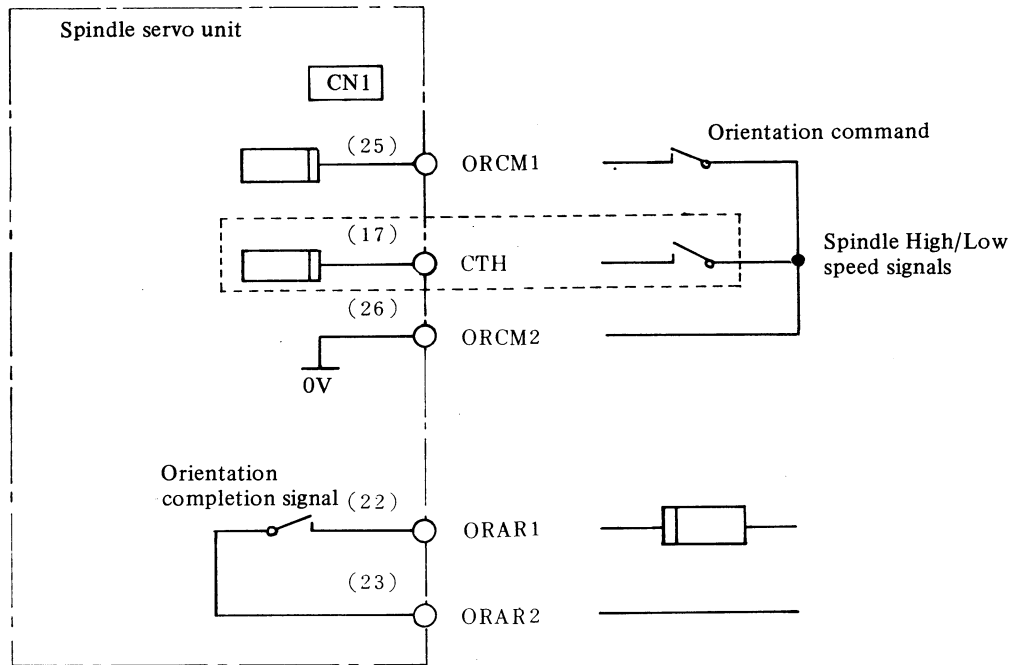
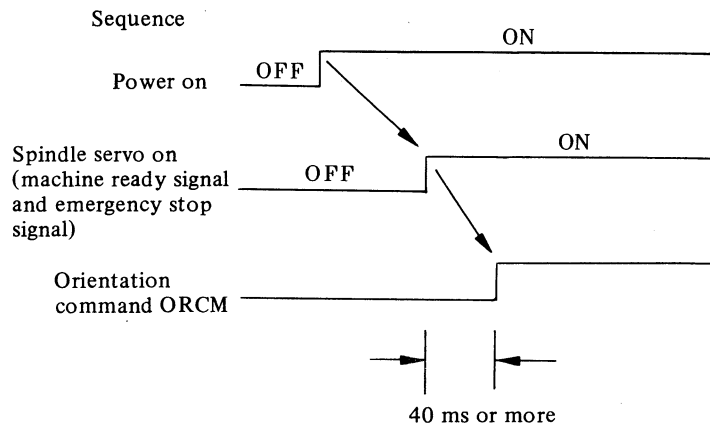

Fig. 7.1 Signals passed between the magnetic cabinet or NC and the spindle servo unit

7.1.1 Orientation command signal (ORCM1, 2)

- 1) This command signal is used to stop spindle movement to the preset position to allow tool change and workpiece loading/unloading.
- 2) When this signal is ON (contact closed) while the spindle is rotating, the rotation decelerates immediately and the spindle moves to the preset position.
- 3) When the ORCM command is issued, turn off the spindle forward/reverse rotation command (SFR, SRV) for safety. In this status, the spindle will not rotate if ORCM1, 2 contact is OFF (open) during orientation.
- 4) Turn OFF (open) this signal by the tool change completion signal or workpiece loading/unloading completion signal.
- 5) Always set the orientation command signal to OFF when turning on power.



- 6) When an emergency stop occurs during orientation, the orientation command signal must be reset. Return the ATC arm to safe position so that it will not be damaged if the spindle or tool rotates when the power is turned on.

7.1.2 Orientation completion signal (ORAR1, 2)

- 1) This signal is issued when the spindle moves within about $\pm 1^\circ$ of the preset position and stops. That is, this signal turns on under the following three conditions;
 - a) Signal ORCM is ON
 - b) Zero speed signal is ON
 - c) The spindle is in the vicinity of the preset position.If the orientation completion signal is not issued within a set period of time after the orientation command signal is input or if the orientation completion signal is issued when the orientation command signal has not been input, it is considered to be abnormal. So it should be detected by power magnetic sequence and an orientation alarm should be issued.
- 2) Tool change or workpiece loading/unloading operations can be started only after the completion signal is on.
- 3) The spindle orientation completion signal is issued when the spindle is within $\pm 1^\circ$ of the preset position. So it does not always indicate that the spindle has stopped completely. Some machine allow a very short operation time for the ATC arm to grip the spindle tool. In this case, start the ATC arm operation after 0.1 to 0.5 sec so that the arm will grip the tool when the spindle has stopped completely.

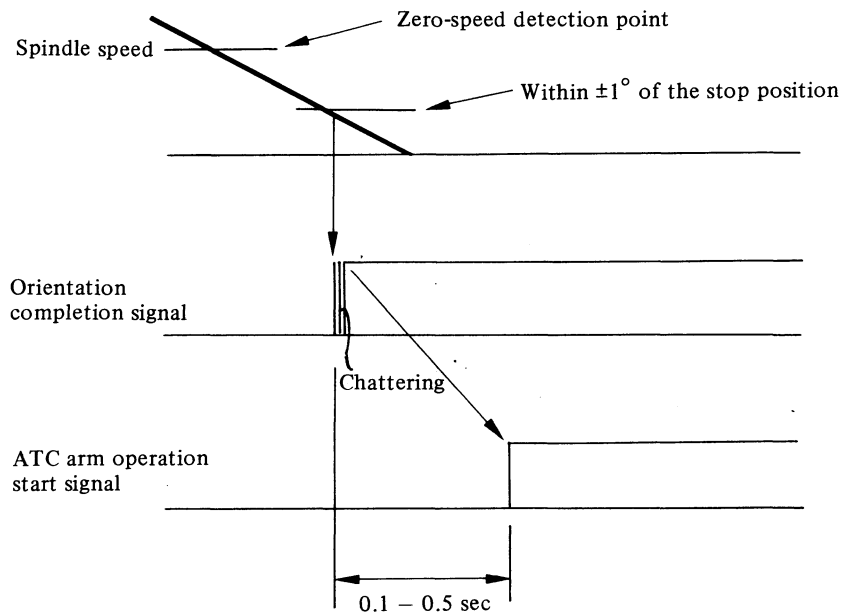

- 4) This signal will turn off during a tool change if the spindle is pushed away from the preset position by an external force. Design a power magnetic sequence so that the tool change operation is interrupted. However, don't release orientation command, and if orientation completion signal is issued again, perform tool change.
- 5) If the automatic tool change (ATC) structure is such that it may cause serious damage if a malfunction occurs, install a proximity switch to generate a verification signal when the ATC enters an area in which automatic tool change operation can be performed. In addition to this the power magnetic sequence should be designed to avoid such damage.

7.1.3 Spindle high-speed/low-speed signal (CTH)

- 1) This signal is used in order to shorten orientation time when there are 2 speed change stages of High/Low between the spindle and spindle motor.
- 2) Increase the spindle motor low-speed gear speed to the spindle motor high-speed gear speed by speed correspond to the gear ratio (high speed/low speed) so that the spindle orientation time of the high- and low-speed gears is almost identical.
- 3) Contact OFF (open) indicates high-speed gear selection, and contact ON (closed) indicates low-speed gear selection.
- 4) Be sure to always use the position coder and magnetic sensor systems when using machines having 2 or less spindle speed change stages.

7.2 Description of Signals (When 3-stage speed change gear spindle)

The following spindle medium speed signal is needed for magnetic sensor system orientation (A06B-6059-J142) and position coders (A06B-6059-J134, J135).

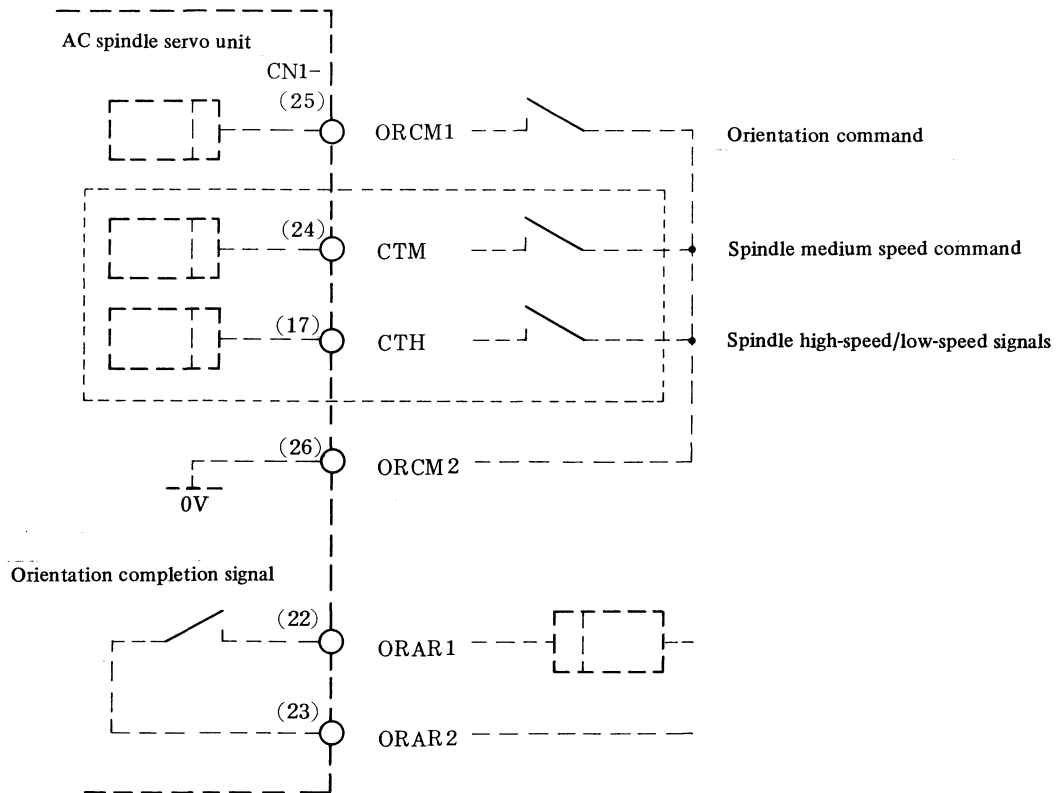

Signals passed between the magnetic cabinet or NC and the AC spindle servo unit

7.2.1 Spindle medium speed signal (CTM)

By combining this signal with the spindle high-speed/low-speed signal (CTH), it is possible to adjust orientation when there are three or four speed gears between the spindle and the motor.

In accordance with the respective speed change stages, control the contact signals as follows:

a) In case of three speeds

Selection of spindle speed change stage	Contact of CTH signal	Contact of CTM signal
High	OFF (open)	OFF (open)
Medium	OFF (open)	ON (closed)
Low	ON (closed)	OFF (open)

b) In case of four speeds

Selection of spindle speed change stage	Contact of CTH signal	Contact of CTM signal
High	OFF (open)	OFF (open)
Medium high	OFF (open)	ON (closed)
Medium low	ON (closed)	OFF (open)
Low	ON (closed)	ON (closed)

7.3 Sequences

7.3.1 Orientation command while stopping

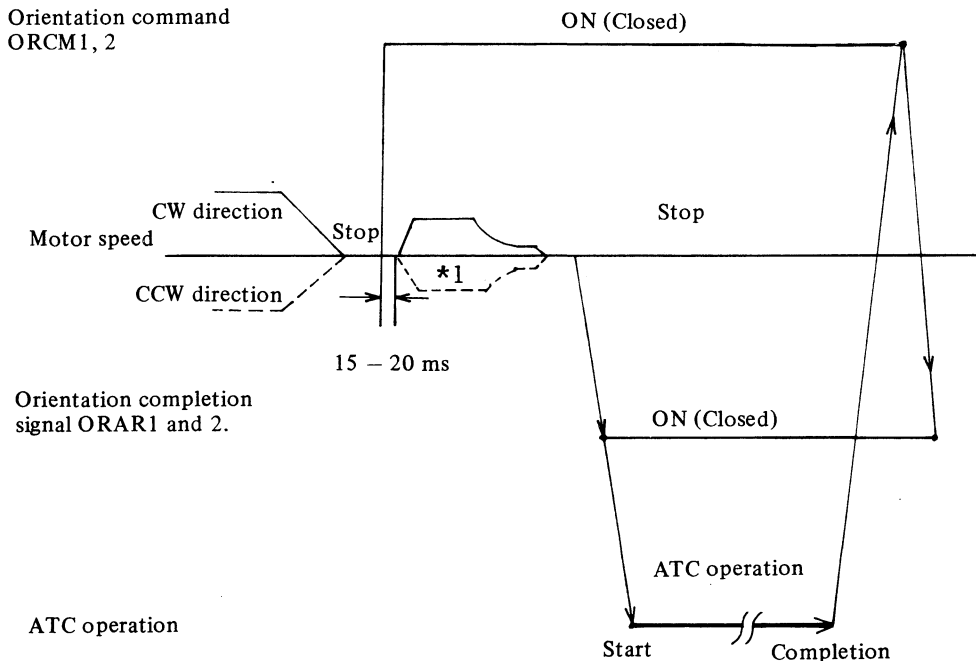

*1 The spindle motor rotation direction can be changed by setting. In standard setting, the spindle motor will rotate in the direction the spindle motor was rotating before this orientation command signal was generated.

7.3.2 Orientation command during high-speed rotation

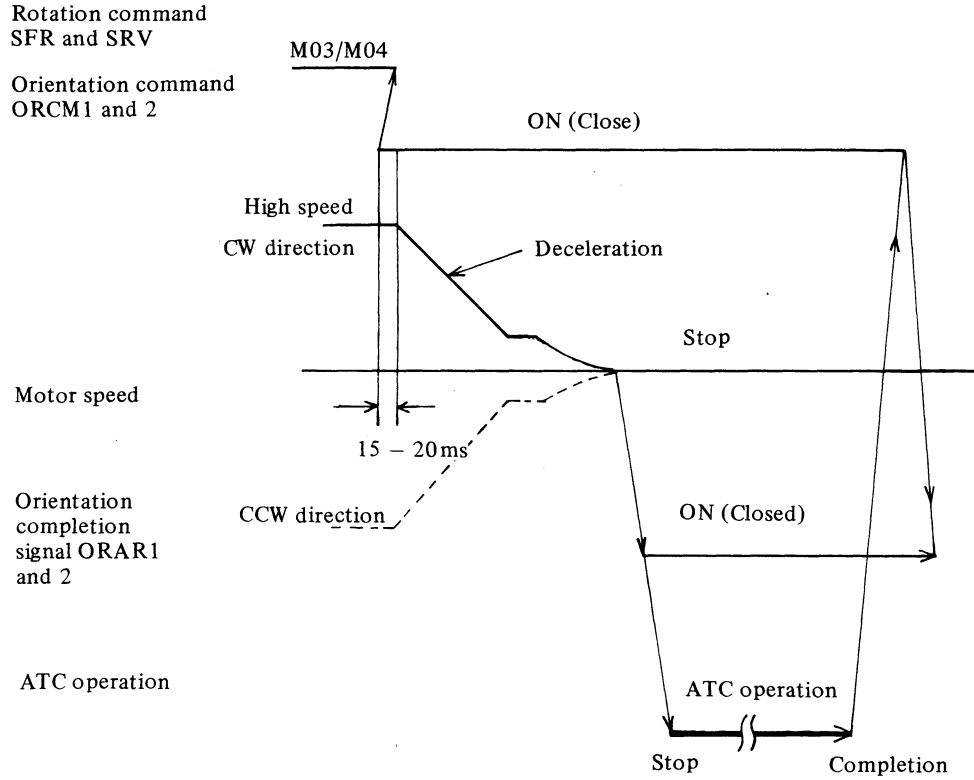

7.4 Description of Signals (Stop Position External Command Type of Position Coder System)

(A06B-6059-J111(Orientation BR11), -J131(Orientation BS11), -J135(Orientation FS))
 (A06B-6059-J113(Orientation BHR11),-J133(Orientation BHS))

7.4.1 Stop position command signals (H01 to H12-OL)

- 1) These 12-bit contact signals are used to control the stop position.
- 2) When these signals are all OFF (open), the spindle is stopped at the reference stop position (0°).
 This reference stop position can be set by using 3 digital switches on PCB.
- 3) Stop position command (In case where a 1024 p/rev position coder is used)
 The following stop positions (X°) are designated according to ON/OFF conditions of H01 to H12 contact signals with reference to the reference stop position (0°).

$$X(\text{degree}) = \frac{360}{4095} \left[\begin{array}{l} 1 \quad 2 \quad 4 \quad 8 \quad 16 \quad 32 \quad 64 \quad 128 \quad 256 \\ (H01)^+ (H02)^+ (H03)^+ (H04)^+ (H05)^+ (H06)^+ (H07)^+ (H08)^+ (H09)^+ \\ + (H10)^+ (H11)^+ (H12)^+ \end{array} \right]$$

The numbers corresponding to H01 to H12 become effective when contacts are turned on and those corresponding to H01 to H12 become zero when contacts are turned off.

Example) H10 contact only is turned on.
 $360/4095 \times 512 = 45^\circ$

In this case, the spindle stops at the position where it is turned clockwise by 45° as viewed from the reference stop position.

- 4) The minimum shift unit is $360^\circ/4095 = 0.088^\circ$.
 When a built-in sensor signal conversion circuit is used, the least moving increment differs corresponding to the number of detection gear teeth as shown in the table below.

No. of detection gear teeth	Least moving increment
256	0.088°
128	0.176°
64	0.264°

- 5) Positioning time
 The positioning time is usually 1.4 to 20 sec when the speed change gear stages are 2 or less.
 It becomes longer as the spindle inertia increases.

6) Setting error

Since the position is set to integer times of the minimum shift unit (0.088°) in case of 30° indexing, 10° indexing, and 1° indexing, a setting error is produced.

Setting error: Max. +0.044°

Example)

30° indexing command (Min. shift unit) x 341 = 29.974° (Error - 0.026°)

10° indexing command (Min. shift unit) x 114 = 10.020° (Error + 0.020°)

1° indexing command (Min. shift unit) x 11 = 0.967° (Error - 0.033°)

To determine actual accuracy, a setting error is added to the repetition positioning accuracy (+0.2°).

7) Necessity of mechanical clamp

A mechanical clamp is required for indexing of the spindle for cutting using this system.

Since the motor is displaced when load fluctuates during cutting, the spindle must be mechanically fixed, if cutting is made after indexing.

8) Mechanical clamp timing

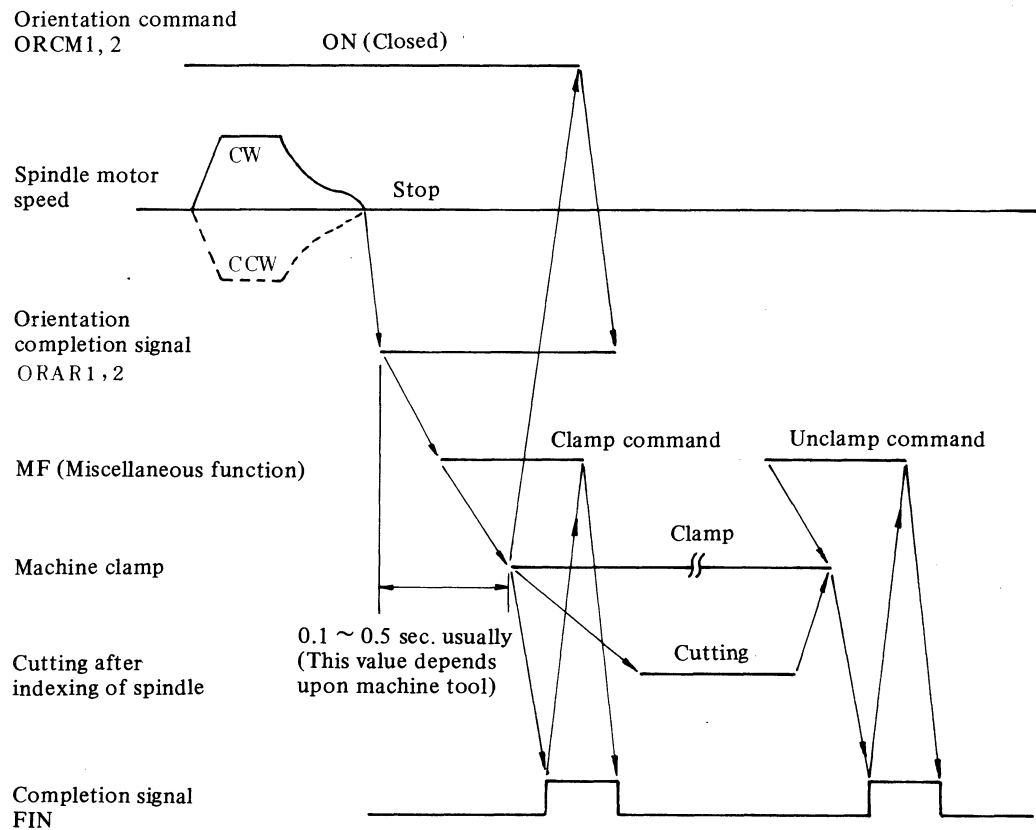

8. DETECTOR SPECIFICATIONS

8.1 Position Coder

1) Electrical specifications

a) Number of square waves/rotation

Channel	Signal
1 ch	1,024 pulses/rotation (A, B phase)
2 ch	1 pulse/rotation (C phase)

b) Power supply

Voltage	Current
+5 V +5%, -10%	400 mA or less

c) Working ambient temperature range

0 to +50°C

d) Output terminal

- Cannon connector MS3102A20-29P: Position coder side

- Cannon connector MS3106A20-29S: Cable side

The cable side cannon connector and the cable clamp are provided with the position coder.

e) Output terminal

A	PA	K	OV
B	PZ	L	
C	PB	M	
D		N	*PA
E		P	*PZ
F		R	*PB
G		S	
H	+5 V	T	
J			

2) Mechanical specifications

a) Input axis inertia: $1.0 \times 10^{-3} \text{ kg.cm.s}^2$

b) Input axis torque : 1,000 g.cm or less

c) Input axis load tolerance

	When stopped	During rotation
Thrust load	10 kg or less	5 kg or less
Radial load	20 kg or less	10 kg or less

d) Structure

The main frame is made of an aluminum alloy finished with alumite.
Dust-proof and oil-proof structure using an oil seal. (IP43)

e) Weight: about 1 kg (without flange)

f) Accessories

No.	Name	Specifications	Number of pieces
1	Cannon connector	MS3106B20-29S	1
2	Cable clamp	MS3057-12A	1

3) Storage

Avoid storing in a humid place.

When moving the product, put it in a packing case and do not drop or throw it.

4) Notes on installation

a) If there is backlash in the interface between the position coder and the spindle, the stop position will vary. Therefore, the position coder should be linked to the spindle so as to eliminate backlash. If the position coder is installed with a timing belt or a gear, check carefully and periodically for backlash due to ageing or mechanical wear.

b) Eccentricity of the body and the center of the axis should be 0.02 or less.

c) Do not give a strong mechanical impact as plate glass is used.

To avoid penetration of oil or water from cannon connector, the cannon connector is to be installed upside down.

d) Keep at least 50 cm away from the magnetics cabinet.

Keep at least 30 cm away from the cable line of a motor or the like; out of which a substantial amount of instantaneous current flows at the time of ON-OFF. Especially, when an object which generates radiation noise (such as discharge processing device, electric welder and the like) is in the vicinity, an electro-magnetic shielding is to be considered.

8.2 Magnetic Sensor

The magnetic sensor makes sure that the spindle stops at the specified position by attaching a magnetizing element to the spindle rotation part and installing a magnetic sensor at the stop position.

The magnetic sensor emits analog signals corresponding to the position of the magnetizing element attached to the spindle.

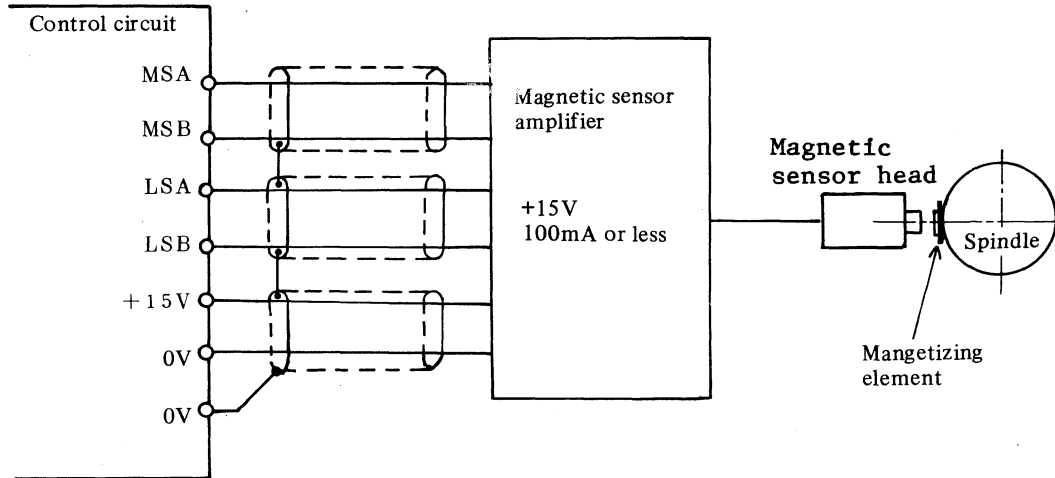

A shielded wire should be used. Shield insulation must be connected to OG. The following shows the magnetic sensor electrical specifications and how to attach the sensor.

1) Electrical specifications

a) Number of waves per rotation

Channel	Signal
1 ch	1/rotation (MSA-MSB)
2 ch	1/rotation (LSA-LSB)

b)

Power supply	Current
+15 V +10%, -10%	100 mA or less

c) Maximum number of rotation (Magnetizing element) : 8,000 rpm

d) Working ambient temperature range (Magnetic sensor): 0 to +50°C

e) Output terminal

Metallic receptacle type. Receptacles for the cable of the magnetic sensor amplifier are provided.

f) Output terminal layout (Magnetic sensor amplifier)

Terminal	Signal name
A	MSA
B	0 V
C	+15 V
D	MSB
E	LSB
F	LSA

g) Weight of magnetizing element, refer to item 5.3.

2) Magnetic sensor mounting method

The following show magnetic sensor mounting examples Fig. 8.2(a), (b), (c), (d).

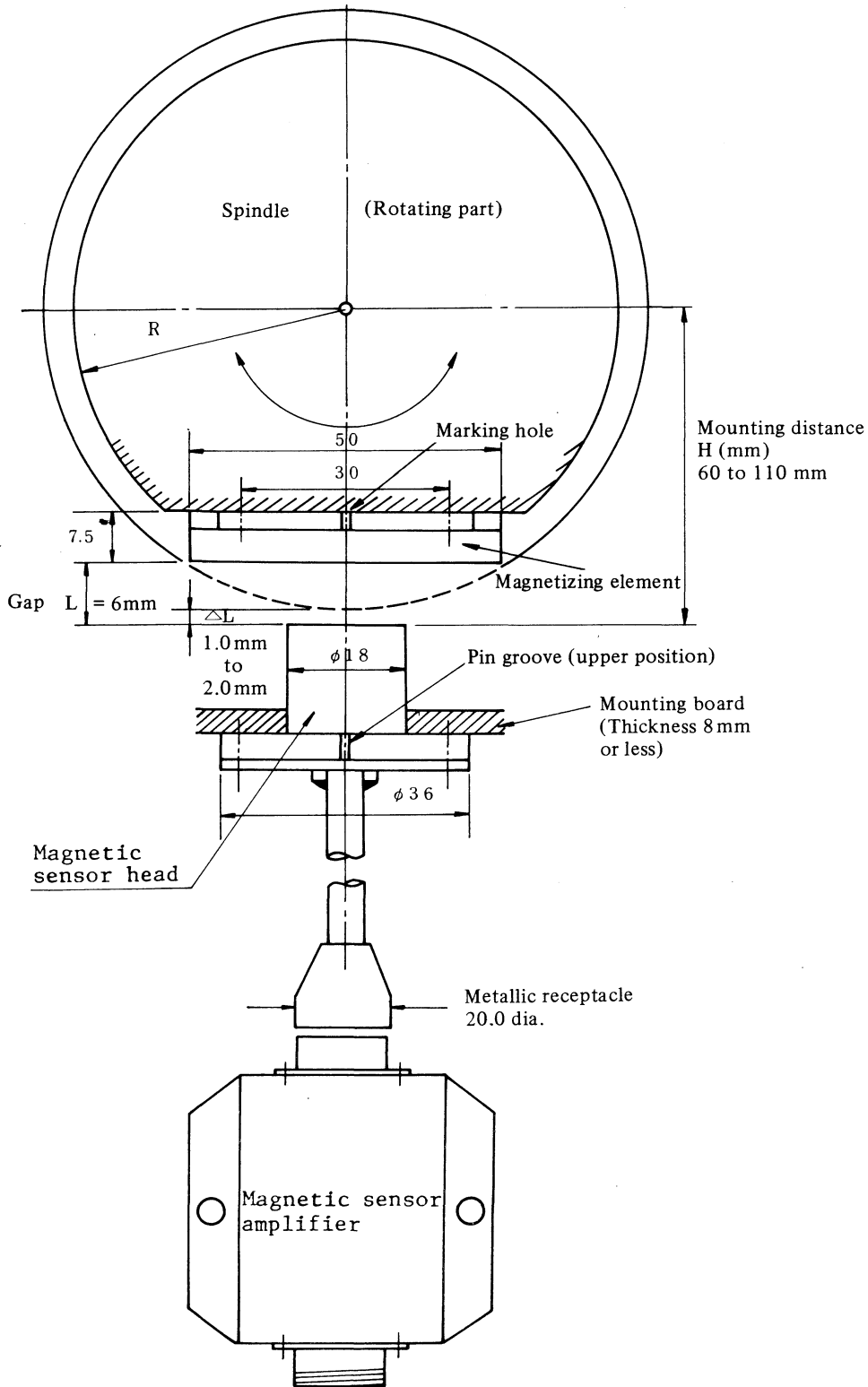
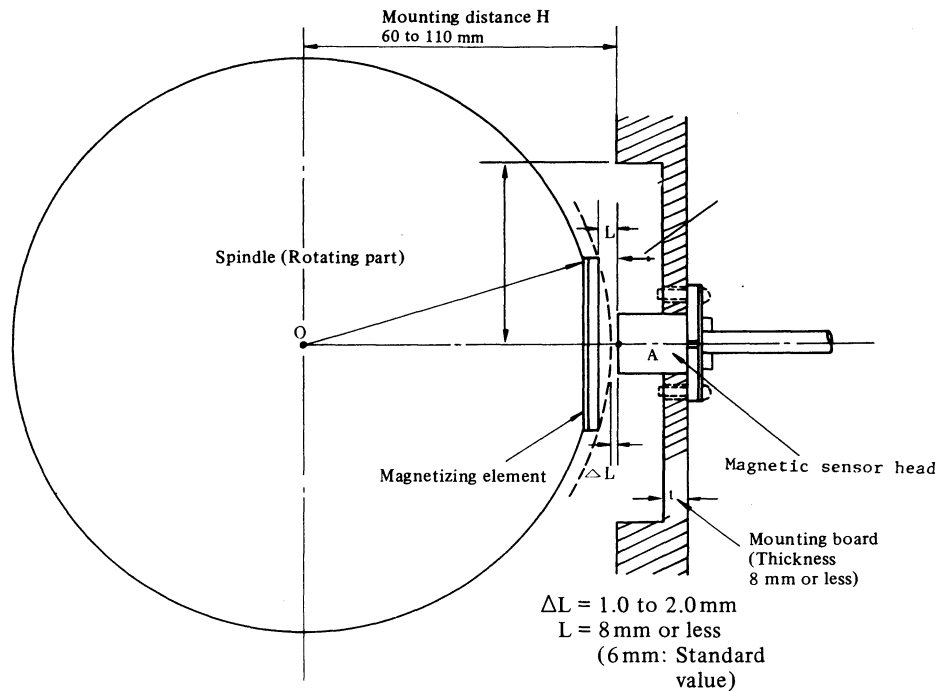

Fig. 8.2 (a) Magnetic sensor mounting example (1)



Note) Gap between mounting board and magnetizing element is 8 mm or more.

Fig. 8.2 (b) Magnetic sensor mounting example (2) (When mounted on cylinder)

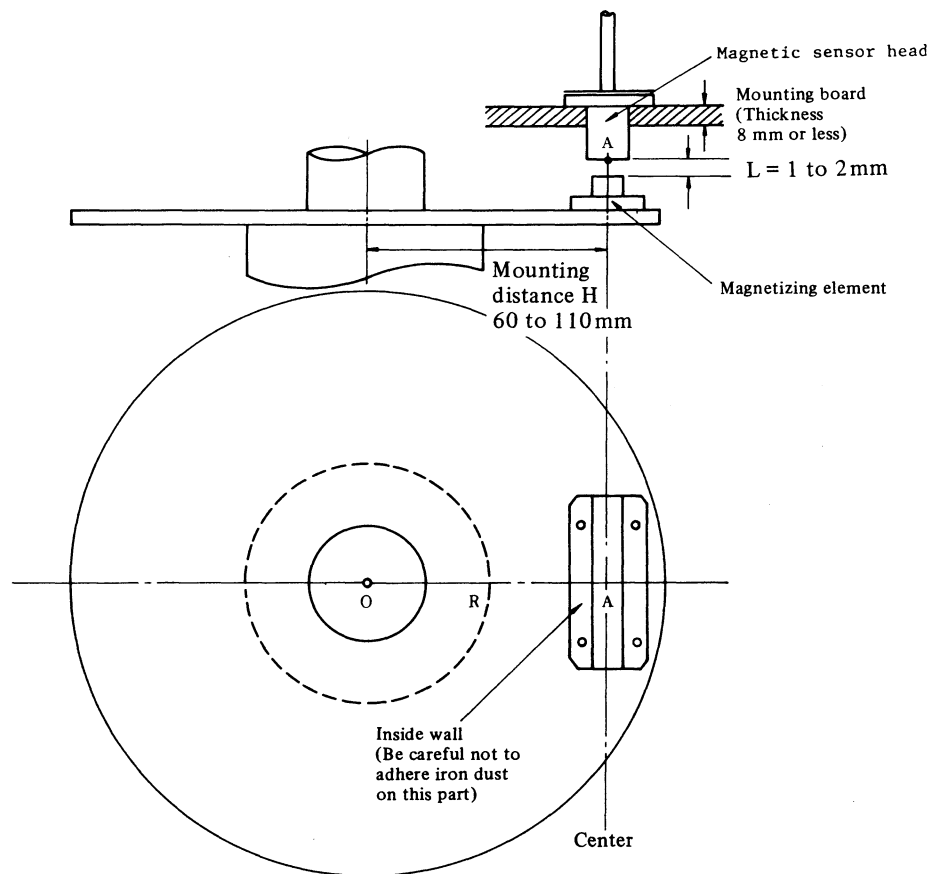

Fig. 8.2 (c) Magnetic sensor mounting example (3) (When mounted on disk)

Mounting method of magnetic sensor

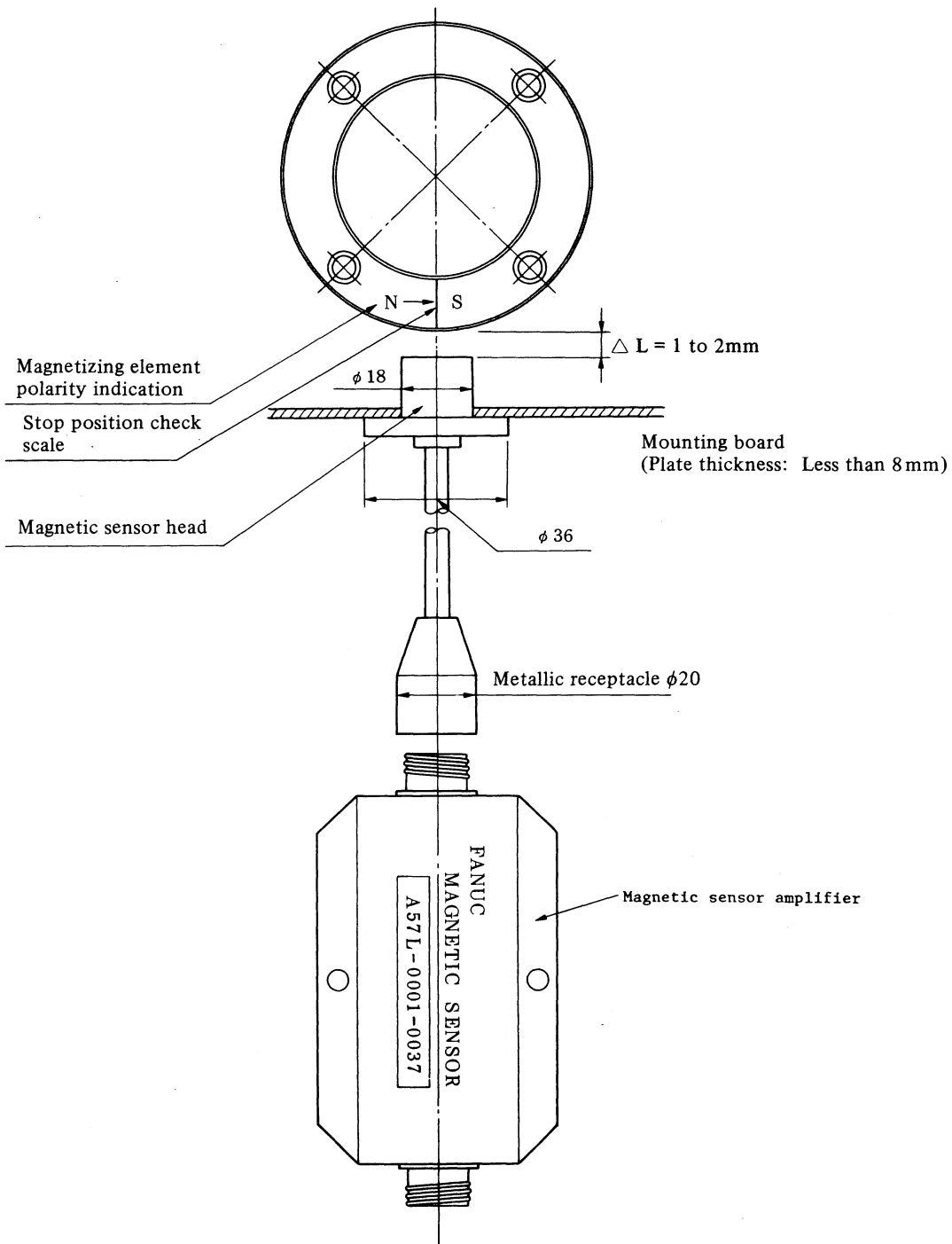

Fig. 8.2 (d) Magnetic sensors mounting example (4) (Q, R, S and T)

a) Magnetic sensor head pin groove

When a magnetizing element is mounted to the spindle of a machine tool, the polarity is produced between the magnetic element and the magnetic sensor, and the mounting direction differs according to the composition of the spindle (belt transmission, gear coupling, etc.)

For the connection shown in the magnetic sensor interface, arrange the relative positions of the magnetizing element marking hole and pin groove of the magnetic sensor as illustrated below.

If this mounting is wrong, the spindle motor will repeatedly turn in the forward and reverse directions without being stopped.

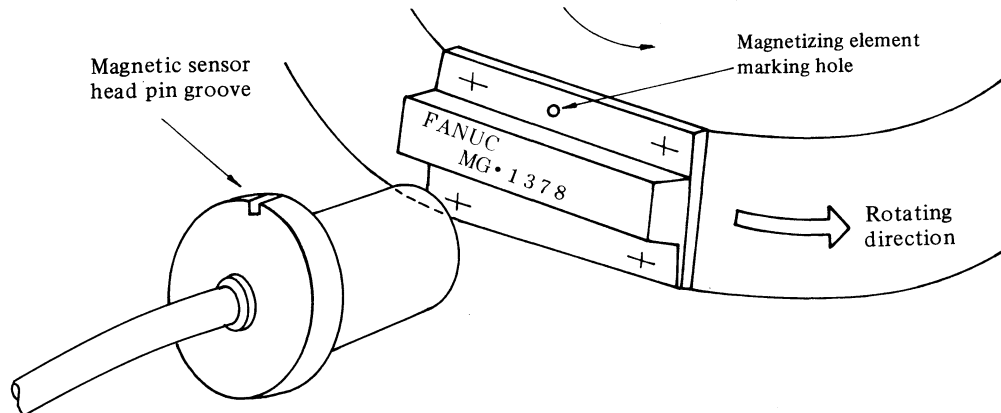

The spindle motor rotates counterclockwise (CCW) as viewed from the motor shaft by forward rotation command (signal SFR contact ON (closed), speed command VCMD (positive voltage)).

Arrange the magnetizing element marking hole and the magnetic sensor pin hole face to face by forward rotation command ON, so that the spindle motor rotates in the rotating direction specified in the figure.

3) Cautions on installation

- a) Since the magnetizing element is mounted onto the rotating body of the spindle, be careful not to allow the magnetizing element to be detached by means of centrifugal force.

Limit the circumferential speed of the magnetizing element to lower than 3770 m/min (N, P type).

(Take the depth of the screw holes of M4 x 4 into consideration)

- b) Mount the magnetic sensor amplifier as close to the sensor as possible.
c) Do not allow a magnetic field producing substance to be close to the magnetic sensor (stop position changes). Do not arrange any solenoid in the vicinity of the magnetizing element, in particular.
d) Be careful not to attach iron powder and other substances sensible to the magnetism to the magnetizing element.
e) If the spindle is provided with a built-in electromagnetic clutch for HIGH/LOW selection and other parts which may compose a magnetic loop, mount the magnetizing element on a non-magnetic substance (aluminum, etc.) without fail.

The magnetic flux of the magnetizing element is zero at the stop position. However, if it is affected by a magnetic loop of the electromagnetic clutch, the magnetic flux is added normally when the magnetic clutch is turned on. It should be carefully noted that if the clutch is turned on and off during the stop at the fixed position, the stop position changes due to a change of the steady-state magnetic flux.

- f) Do not contaminate the magnetic sensor cable, sensor amplifier, and connecting cables with lubrication oil and cutting oil.
- g) Mount the magnetizing element of the magnetic sensor onto the spindle directly.

If the magnetizing element is mounted by gear coupling or spindle coupling, the repetition orientation accuracy may fluctuate by a backlash quantity between the spindle and the magnetizing element. Examine this accuracy by taking a change due to a secular change caused by mechanical abrasion, etc. into consideration.

(Installation example 1)

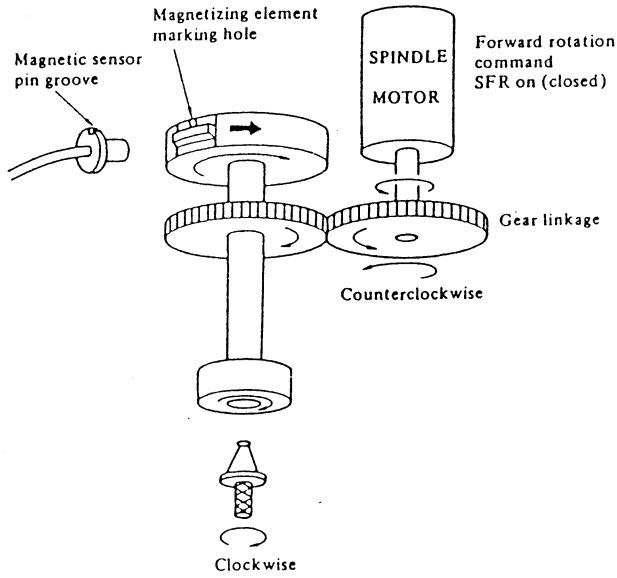

(Installation example 2)

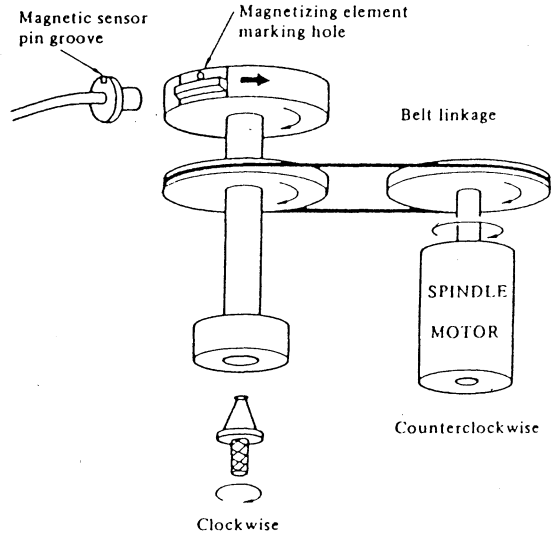

(Installation example 3)

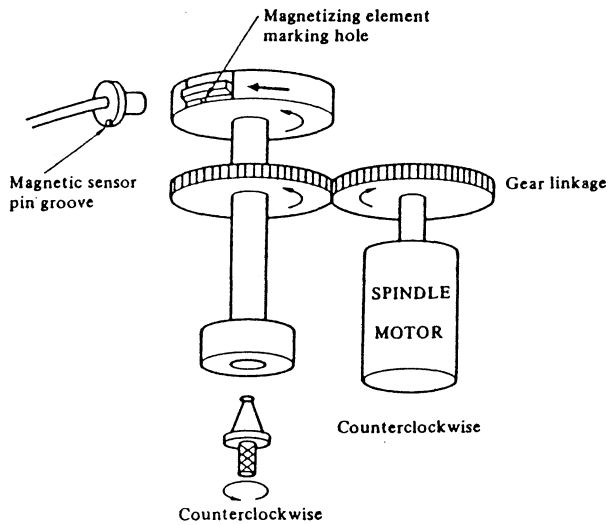

(Installation example 4)

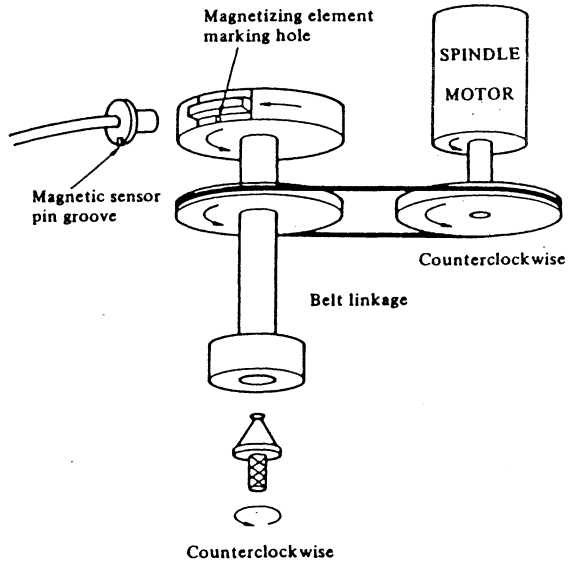

(Installation example 5)

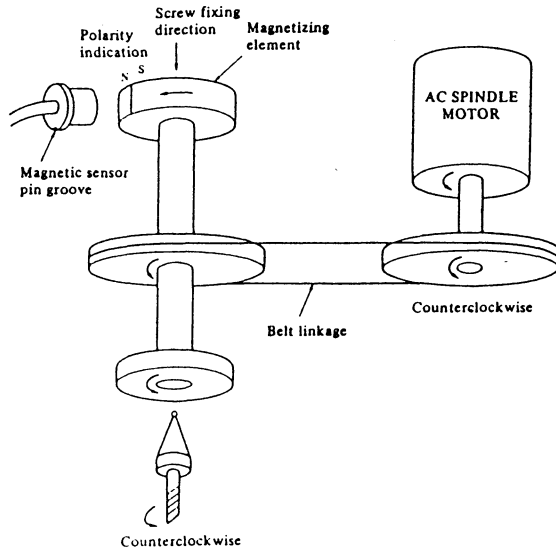

(Installation example 6)

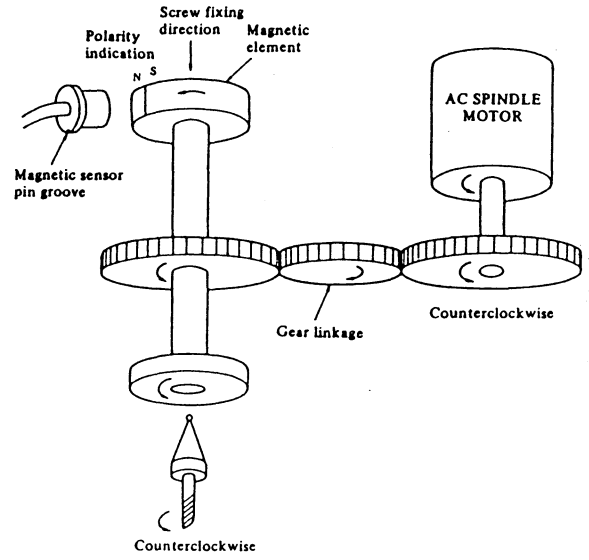

9. TWO-MAGNETIC SENSOR ORIENTATION

9.1 General

According to this technical data, a spindle can be selectively stopped at two different orientated positions by two magnetic sensors.

9.2 Configuration

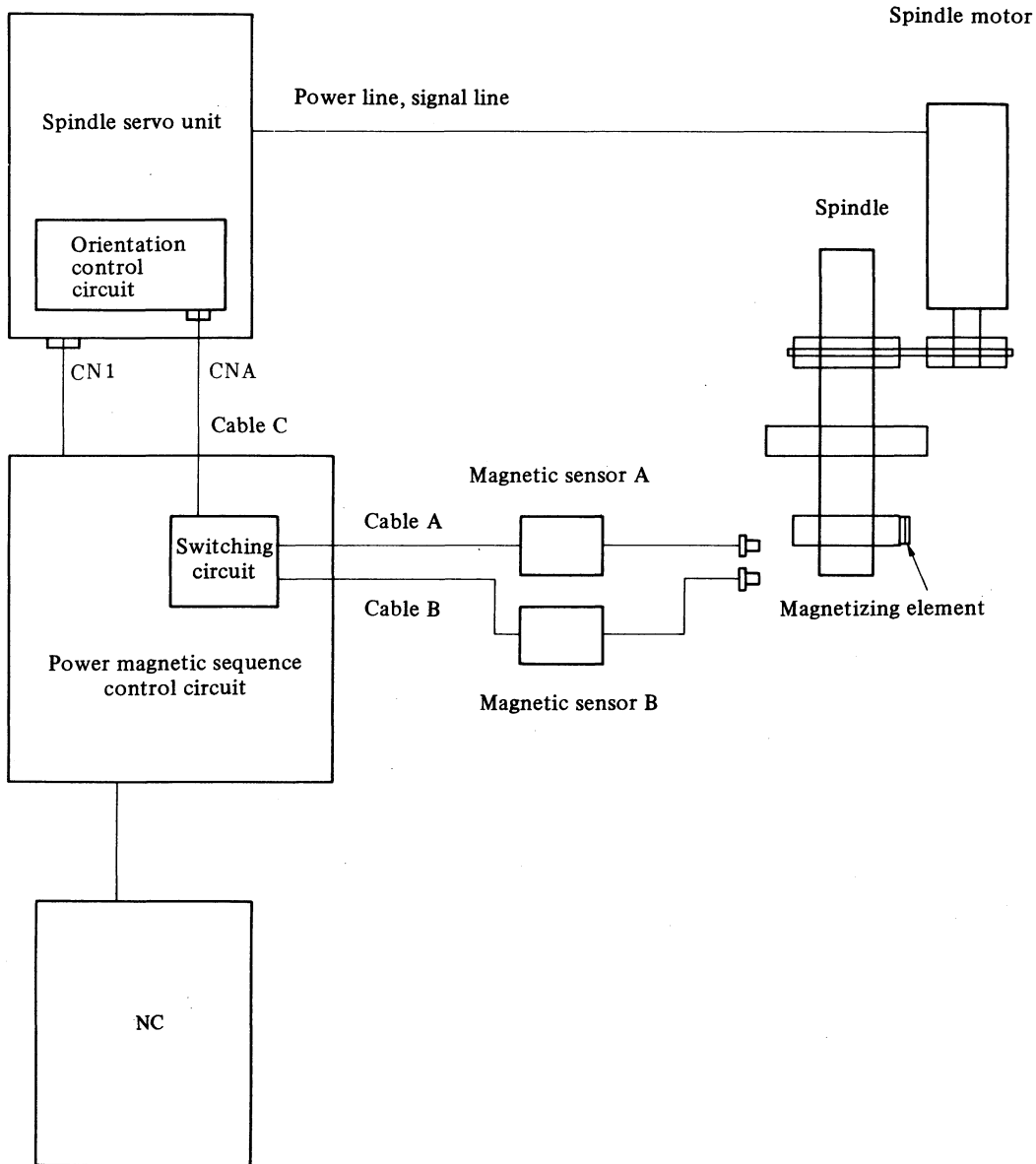

(Notes related to Configuration Drawing)

1. It is necessary to install a switching circuit to allow switching of the magnetic sensor signal in the power magnetic sequence control circuit. This switching circuit is to be provided by the user.
2. Two magnetic sensors are required.
Magnetic sensor specification: A57L-0001-0037/()

9.3 Change-over Circuit

The change-over circuit is shown in next page.

The MSA and LSA signals of the magnetic sensor A and B are transferred to the orientation circuit by shifting them within a change-over circuit.

9.3.1 Selection signal of magnetic sensor (SB signal)

When the SB signal is set at HIGH LEVEL, the magnetic signal A is selected. When set at LOW LEVEL, the magnetic sensor B is selected by actuating the relay. The power +V supplies voltage to the relay solenoid. For changing timing, select the selection signal of magnetic sensor (SB) so that it may be completed before turning ON the orientation command (ORCM) as in the figure below.

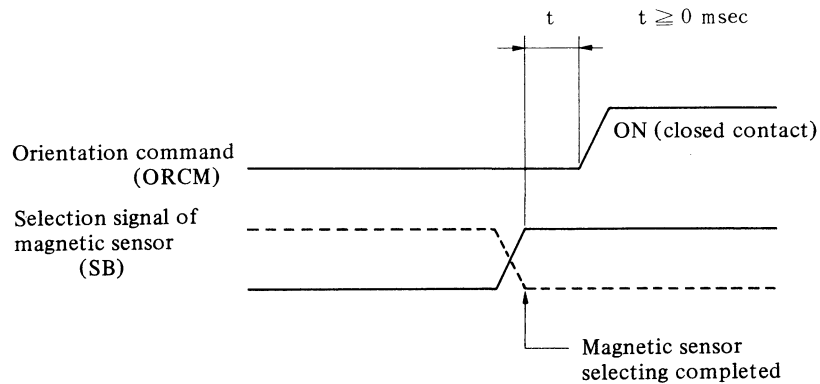

9.3.2 Signal change-over relay

1) Contacting point type

Contacting points for two circuits are switching simultaneously with a single operation coil and contacting point between 1 and 2 (or point 3 and 4) may not be shorted out.

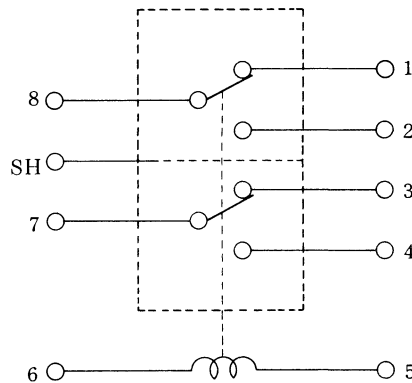

Note 1) Numbers are given for convenience.

Note 2) The SH terminal is used for shielding statics.

- 2) Contact resistance : 100 mΩ or less
- 3) Capacity of contacting point : 1 VA or greater
- 4) Switching life of contacting point: Select according to the actual frequency of use.

Switching circuit interface

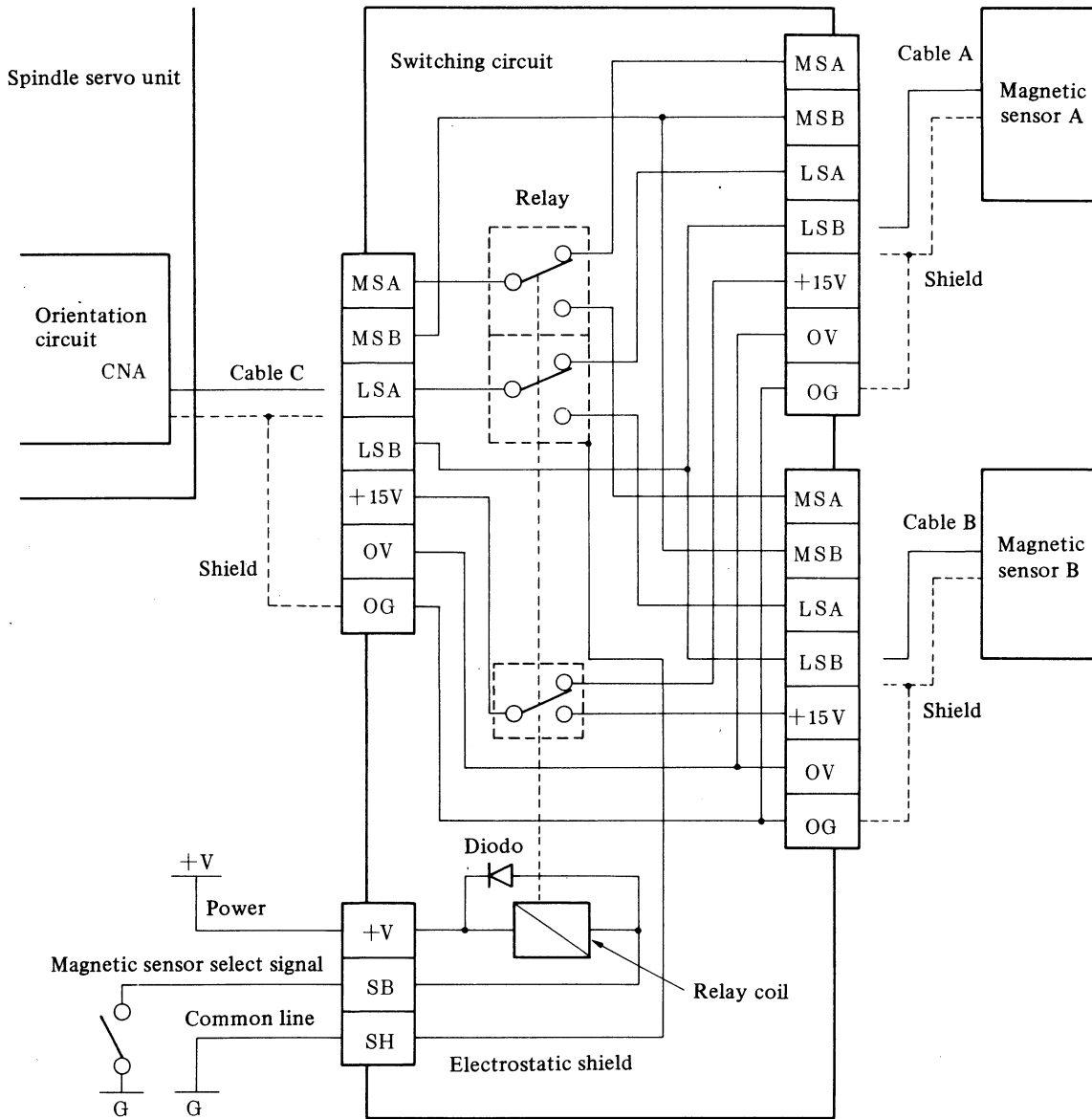

Internal wiring of circuit should be as short as possible.

9.4 Fine Adjustment for Stop Position

In two-magnetic sensors type, design on machine side is required to enable fine adjustment for the other side stop position since fine adjustment for stop position can be done at only one side.

VI. SPEED GAIN SWITCHING CIRCUIT

1. GENERAL

The speed gain switching circuit (models 6S - 22S) controls, while switching by the external signals, the speed loop gain in the AC spindle servo unit. It improves the accuracy as well as the stability of the spindle at the time of stop at oriented position of the spindle; while raising speed loop gain in the AC spindle servo unit by contact signals whenever an oriented position stop control is performed while making use of one of the position control circuits other than the spindle orientation circuit of the AC spindle servo unit by catching the feed back signal of position from the position coder which is linked directly to the spindle of the NC machine tool. Use this circuit without fail when performing spindle oriented position stop control by employing the NC position controller.

2. FEATURES

- 1) A stable control is available
A stable control, such as an improvement of the accuracy of orientation, is possible when using one of the position control circuits except that of the option for the AC spindle servo unit S series.
- 2) Easy control
A control can easily be done only with the contact signal.

3. CONFIGURATION AND ORDER SPECIFICATIONS

3.1 Configuration

The option of the speed gain switching circuit is connected to the PCB of the AC spindle servo unit S series.

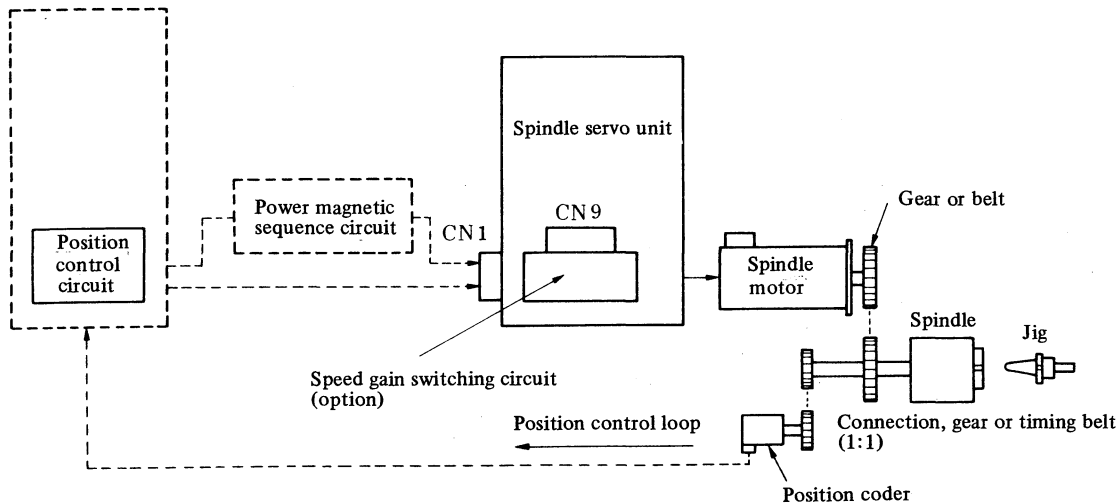

3.2 Order Specifications

Category	Name	Specifications
Option	Speed gain switching circuit	A06B-6059-J700

4. EXTERNAL DIMENSIONS

The connecting cables to the PCB of the AC spindle servo unit is not included.

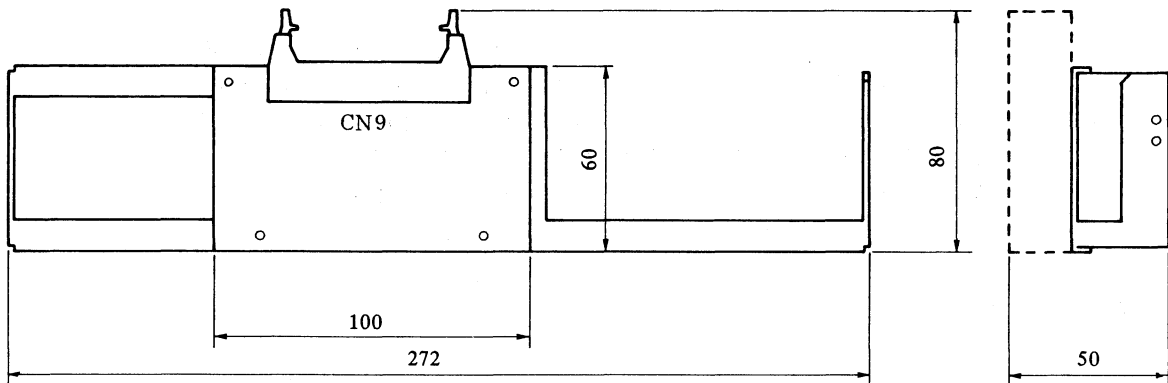

5. DESCRIPTIONS OF INTERFACE SIGNALS

Describes the interface signals on which special precautions are to be taken when using the speed gain switching circuit. As for the signals other than the under-mentioned, refer to the item 10 of "II AC SPINDLE SERVO UNIT S series".

5.1 Forward Rotation Command Signals (SFR, OS)

- 1) Command forward rotation (SFR) without fail, as for the rotating direction command utilizing the speed gain switching circuit. (Pay attention as reverse rotation command cannot be used.)
- 2) With the contact ON (closed), the spindle motor rotates counterclockwise (CCW) as viewed from the motor shaft when the speed command voltage is in the positive direction, and rotates clockwise (CW) when the voltage is in the negative direction.

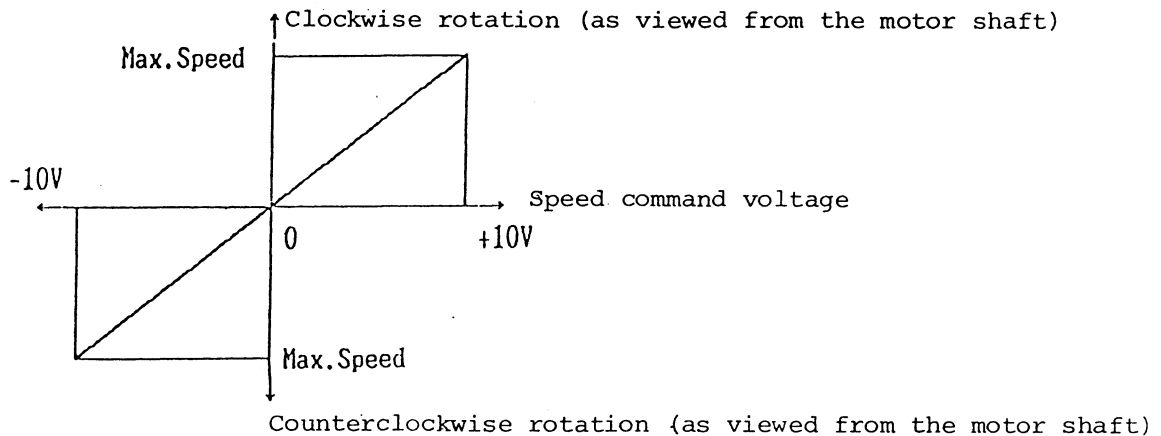

Relation between the command voltage and the rotating speed

5.2 Orientation Command Signals (ORCM1, ORCM2)

- 1) This is the contact signal used for raising the speed loop gain by switching it from the exterior when utilizing the speed gain switching circuit, and there is no spindle orientation function. Switching of speed loop gain is carried out when the contact of this signal is ON (closed) and the rotation speed of the motor becomes less than about 1/100 of the maximum rotating speed.

- 2) Although the forward rotation command becomes ineffective when this signal is input, keep the forward rotation command in OFF (open) status while this signal is given, in order to maintain the safety. In this way, it keeps the spindle motor from turning should the contact of ORCM1 or ORCM2 be in OFF (open) status during orientataion or in case the orientation is released.

6. OPERATION WHEN USING THE SPEED GAIN SWITCHING CIRCUIT

6.1 Operation at the Time of Stop

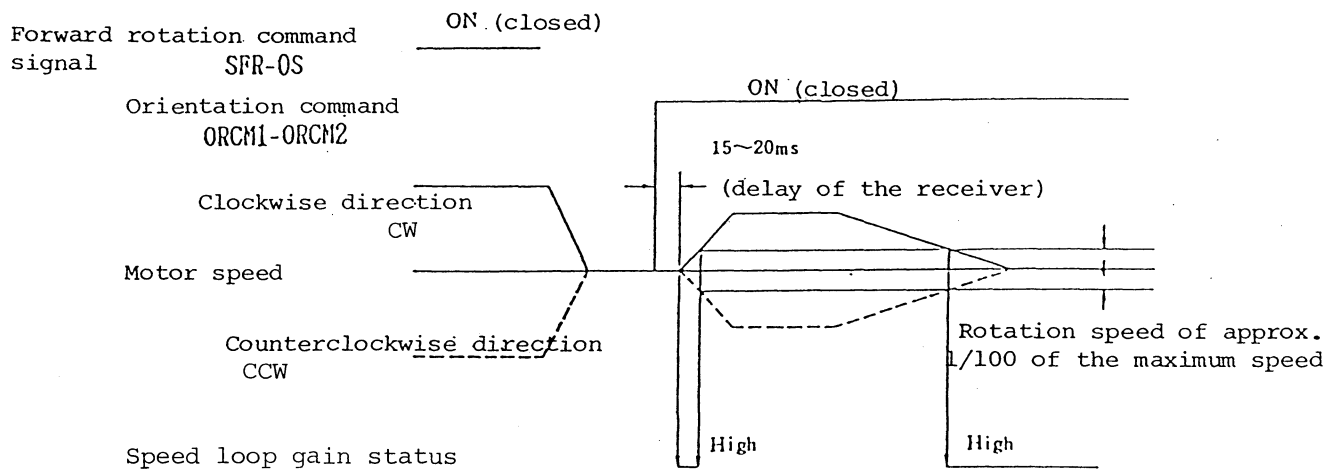

6.2 Operation as from Rotating at High Speed

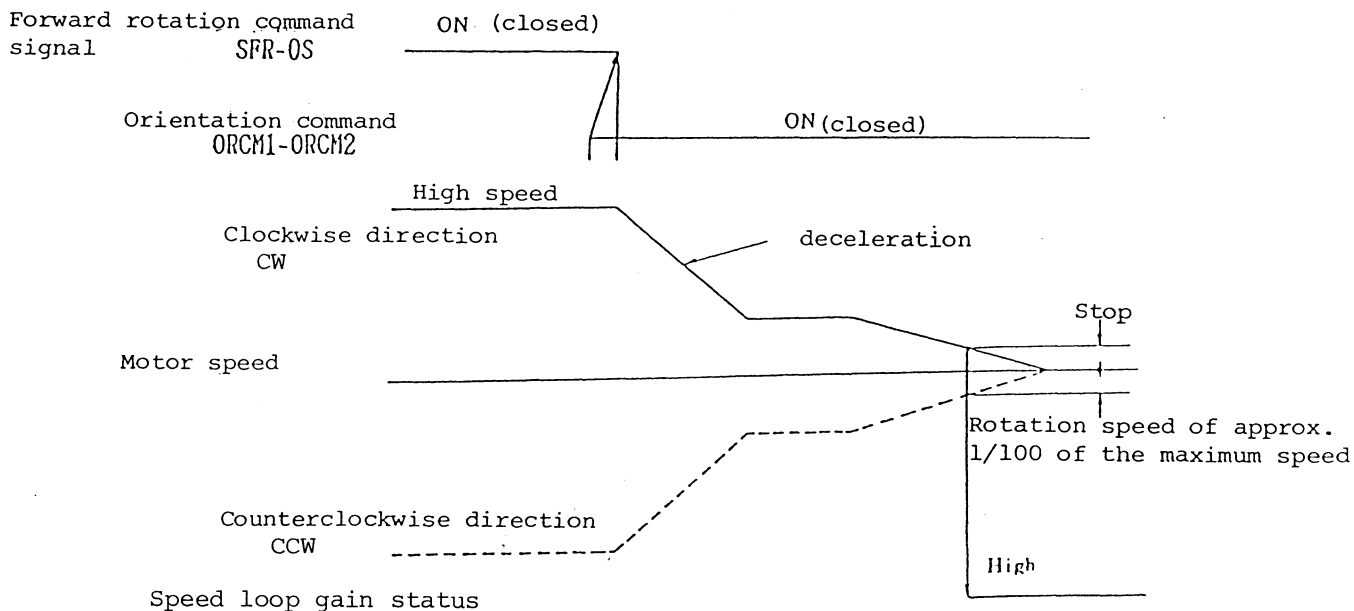

VII. BUILT-IN SENSOR SIGNAL CONVERSION CIRCUIT

1. GENERAL

This chapter describes the signal conversion circuit for outputting signals for speed detection and for the position coder by receiving signals from the built-in sensor used for the AC spindle motor and the built-in motor of the built-in type NC machine tools.

2. FEATURES

- 1) With a single set of this signal conversion circuit, you can obtain both the signals for speed control of the motor and the signals for the position coder.
- 2) The external dimensions of the AC spindle motor of the built-in sensor type is the same as those of the S series standard.
- 3) A function has been added which monitors the detection signal level and, when any abnormality is found, issues an alarm (that wire disconnection has been detected).

3. CONFIGURATION AND ORDER SPECIFICATIONS

3.1 Configuration

3.1.1 When position coder system orientation is used

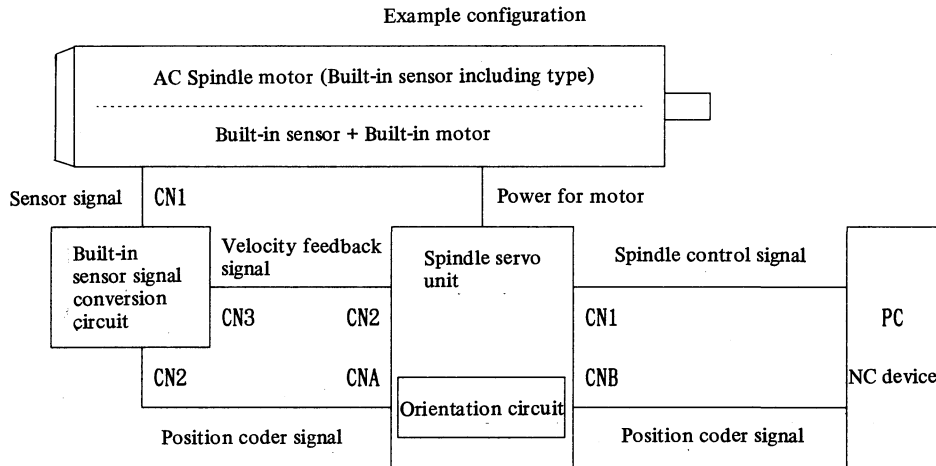

3.1.2 When position coder system orientation is not used

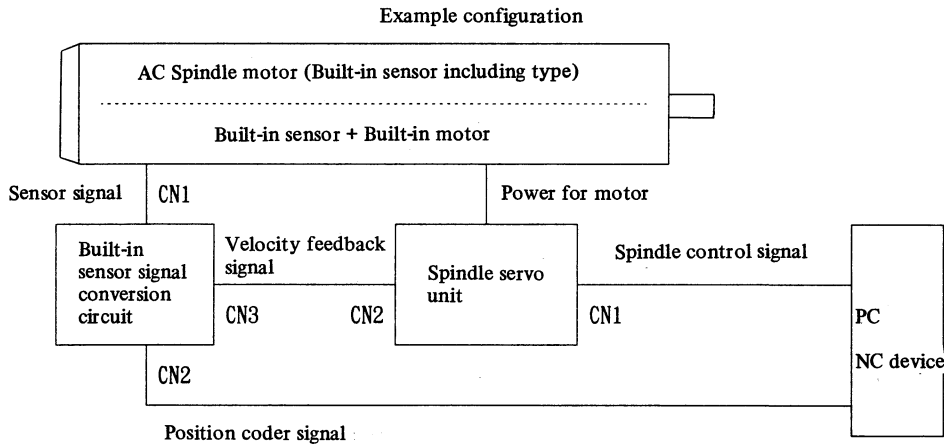

3.2 Order Specifications

3.2.1 Built-in sensor signal conversion circuit

Category	Name	Specifications	PCB DWG. No.
Option	Built-in sensor signal conversion circuit	A06B-6063-H730	A16B-1600-0440

3.2.2 Built-in sensor built-in type AC spindle motor

Category	Name		Specifications	Remarks	
Basic	Model 1S	Flange mount type	A06B-0750-B190	8000rpm, exhaust rear	512p/rev. Note 1)
	Model 1.5S	Flange mount type	A06B-0751-B190	8000rpm, exhaust rear	
	Model 2S	Flange mount type	A06B-0752-B190	8000rpm, exhaust rear	
	Model 3S	Flange mount type	A06B-0753-B190	6000rpm, exhaust rear	
	Model 6S	Flange mount type	A06B-0754-B190	4500rpm, exhaust rear	1024p/rev. Note 1)
	Model 8S	Flange mount type	A06B-0755-B190	4500rpm, exhaust rear	
	Model 12S	Flange mount type	A06B-0756-B190	4500rpm, exhaust rear	
	Model 15S	Flange mount type	A06B-0757-B190	4500rpm, exhaust rear	
	Model 18S	Flange mount type	A06B-0758-B190	4500rpm, exhaust rear	
	Model 22S	Flange mount type	A06B-0759-B190	4500rpm, exhaust rear	

Note) You can obtain an equal signal with the position coder by using the signal conversion circuit, however, there are two pulse numbers; that of 512 p/rev. and 1024 p/rev.

4. SPECIFICATIONS

4.1 Position Coder Output Signal

4.1.1 Number of detection gear teeth and output pulses

	No. of detection gear teeth/one rotation	Magnification	SH 6	SH 7	No. of output pulses/one rotation	Remarks
Phase A Phase B	512 teeth/rotation	2	A	A	1024 pulses/rotation	Compatible with A06B-6044-H606
	256 teeth/rotation	4	B	A	1024 pulses/rotation	Compatible with A06B-6044-H603 and H605
	128 teeth/rotation				512 pulses/rotation	
	64 teeth/rotation				256 pulses/rotation	
	--	8	A	B	--	Not used.
	--	16	B	B	--	Not used.
Phase Z	One tooth/rotation	1			One pulse/rotation	Same as before

Note) Magnification is set with the setting pins SH6 and 7.

4.1.2 Output signal specifications (connector CN2 signal) at constant speed of 1500 rpm

Point to be measured	Item	Standard	Example waveform
Between CN2-16(PA) and CN2-18(PB) and between CN2-17(*PA) and CN2-19(*PB)	Phase difference	$90 \pm 10^\circ$ (When rotating clockwise viewed from the gear side)	
CN2-16(PA) CN2-18(PB) CN2-17(*PA) CN2-19(*PB)	High level	Minimum 2.5 V	
	Low level	Maximum 0.5 V	
PA, *PA, PB, *PB	Duty ratio	$50 \pm 7\%$	
CN2-14(SC) CN2-15(*SC)	Width	$116 \pm 21 \mu s$	

4.1.3 Output circuit configuration

Balanced output with line driver IC AM26LS31

4.2 Input Power Source

Applicable range of voltage	Maximum applicable current
+5 V +5% -5%	200 mA

4.3 Maximum Speed for Use

Number of detection gear teeth	512 teeth	256 teeth	128 teeth	64 teeth
Maximum speed	5000 rpm	10000 rpm	20000 rpm	40000 rpm

4.4 Temperature Range for Use

0 - +55°C

5. ADJUSTMENT

When the built-in sensor is installed by the user, the adjustment described below is necessary.

5.1 Configuration of Output Signal (Speed Detection Signal)

Measuring conditions	CH20-CH10, CH21-CH10
Direction of rotation CW, CCW	
Speed 1500 rpm	

Note) Set so that output signal ripple is 70 mV or less (detected vibration of 30 μ m or less). If the value is 70 mV or more, the adjustment described in 5.2 may not be possible.

CH10; DC 2.5V V_s ; 0.36 - 0.5V

5.2 Offset Adjustment (Position Detection Signal)

Adjustment location	Measurement location	Measurement conditions	Adjustment value	Measurement device	Remark
VR1	CH7-CH10	Direction of rotation CW, CCW Speed 1500 rpm	0 \pm 56mV	Digital multimeter (Iwatsu SC-7404 etc.) DC range	Adjust so that the adjustment values will be the same in both the CW and CCW directions
VR2	CH8-CH10		0 \pm 56mV		
VR3	CH9-CH10		-170mV - -230mV		

5.3 Example of Wave Pattern

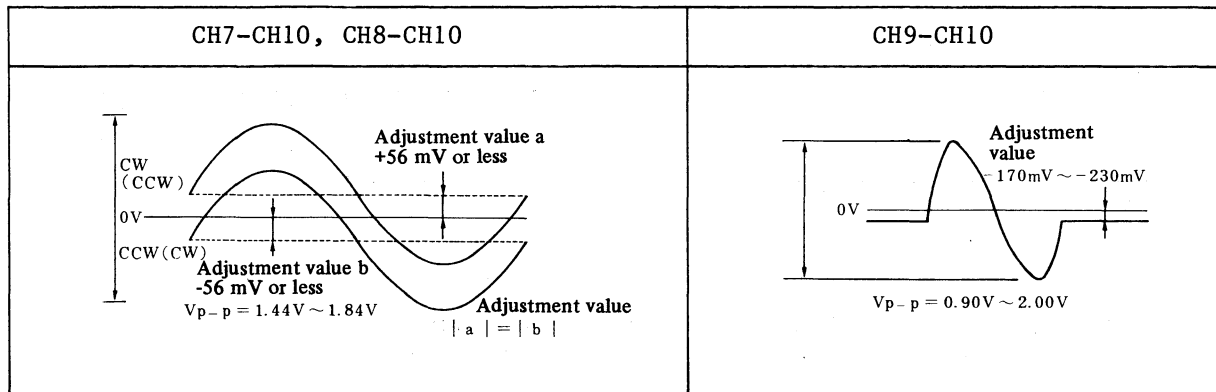

6. EXTERNAL DIMENSIONS AND EXAMPLE OF MOUNTING

6.1 Built-in Sensor Signal Conversion Circuit

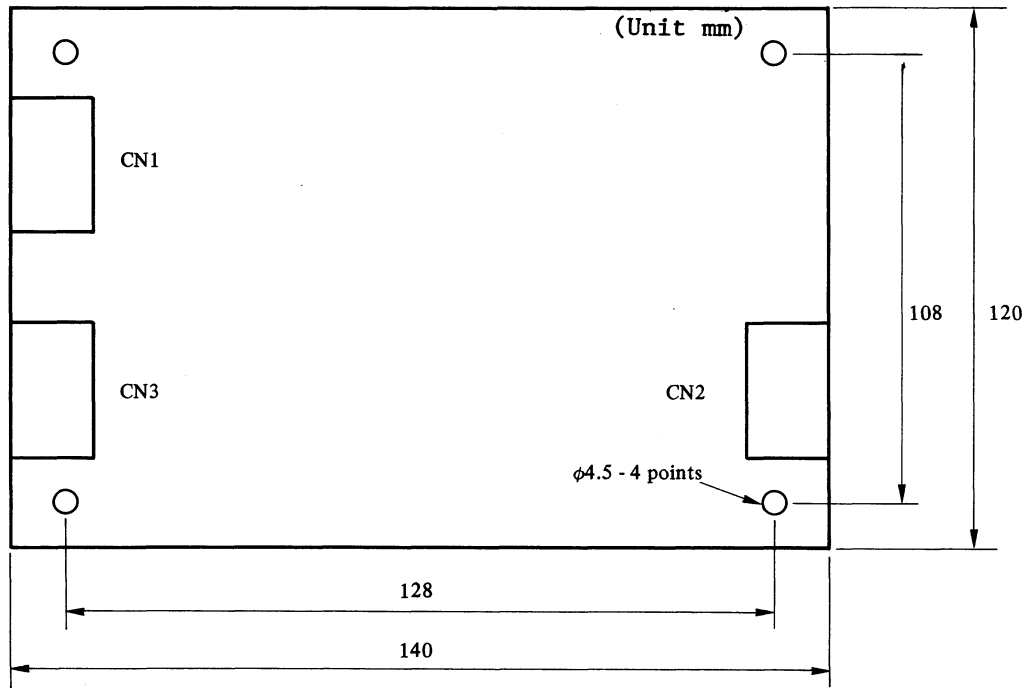

6.2 Built-in Sensor Built-in Type AC Spindle Motor

Refer to the chapter "I. AC SPINDLE MOTOR S SERIES".

6.3 Example of Mounting

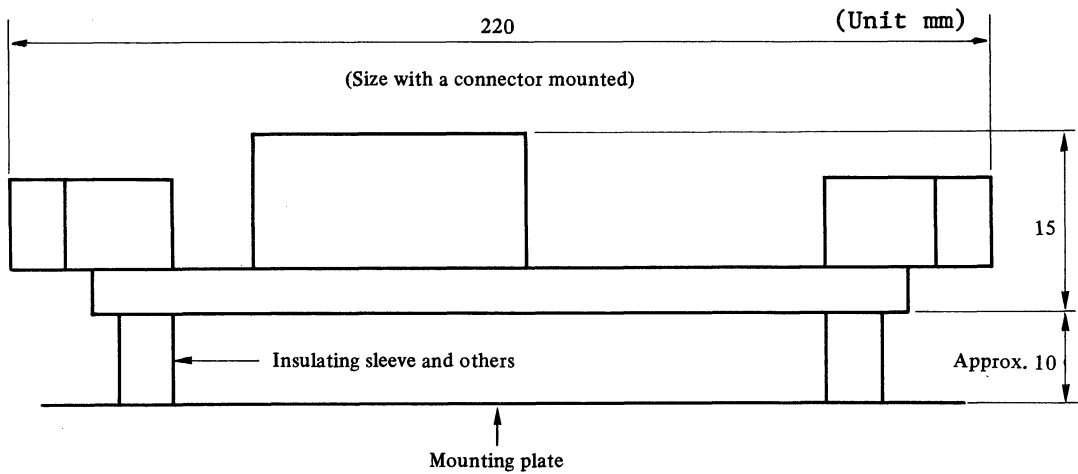

A PCB shall be mounted apart by setting an insulating sleeve, etc.
Install within 1 m from the spindle servo unit.

7. CONNECTION

7.1 When using Position Coder Method Orientation

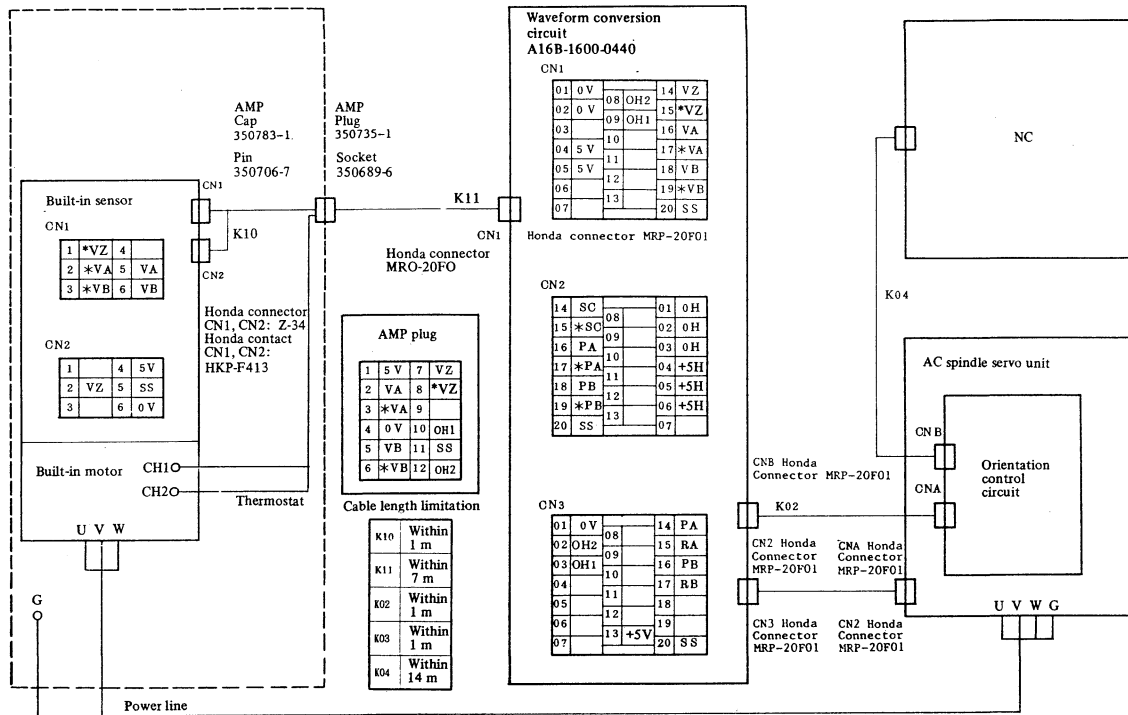

7.2 When not using Position Coder Method Orientation

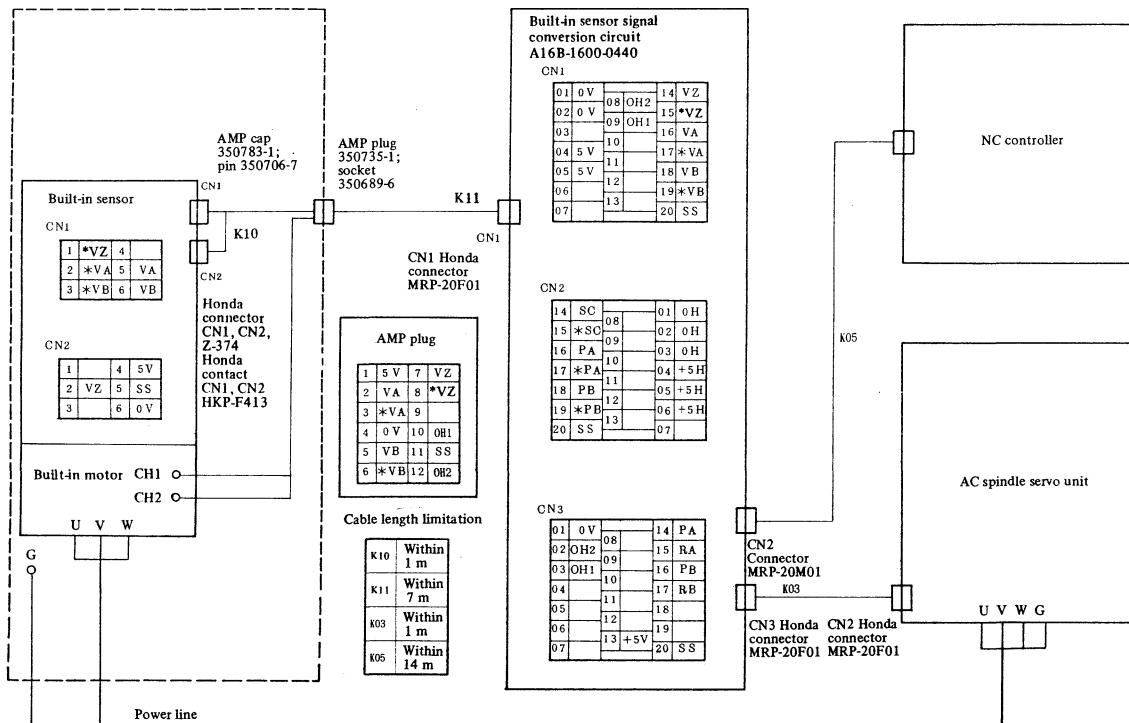

7.3 Details of Connection between Each Unit

7.3.1 Built-in sensor and connector (Motor) (Cable symbol: K10)

(The cable is built-in in the case of built-in sensor built-in type AC spindle motor.)

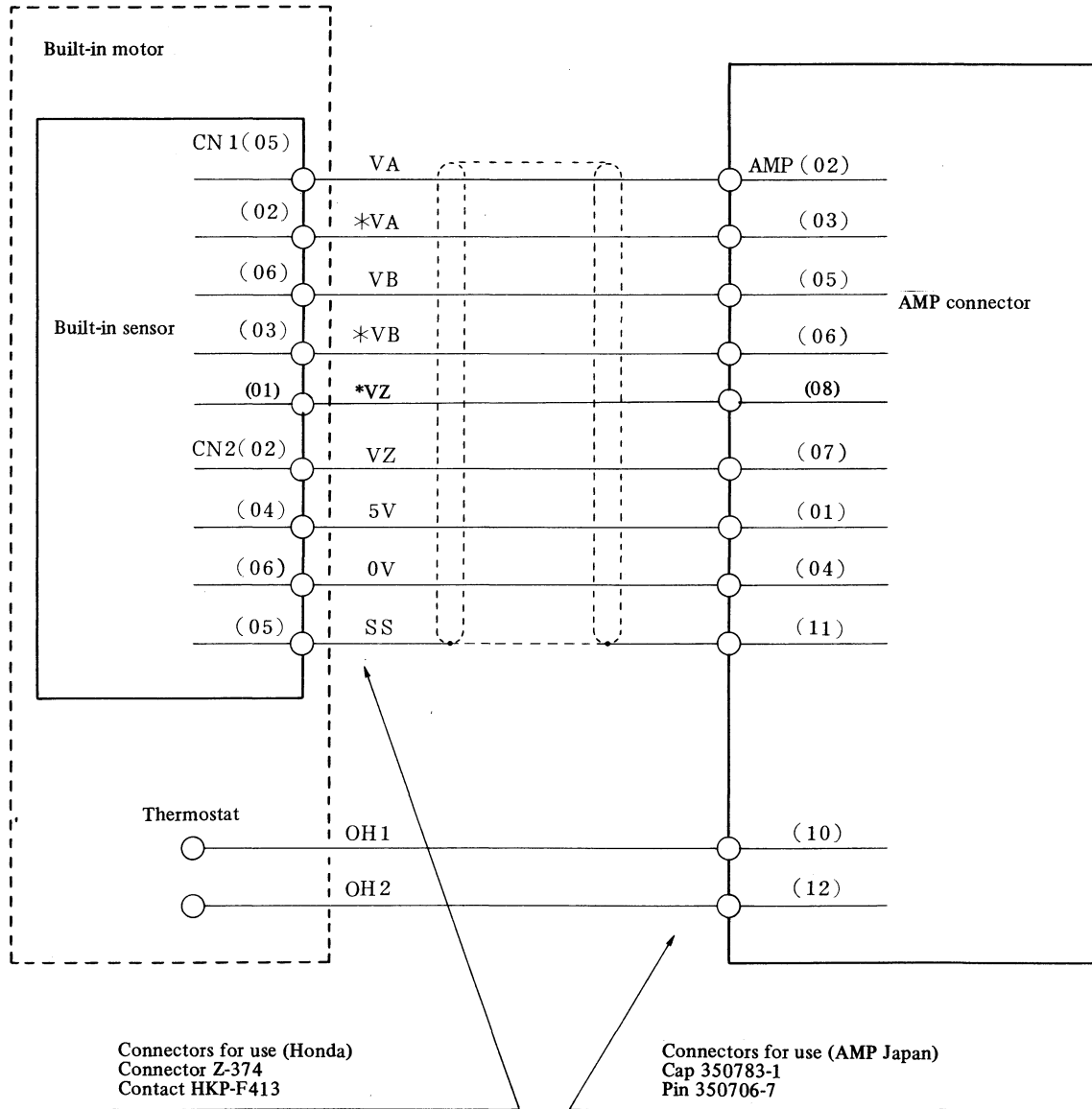

Cables for use: 8-wire of shielded cable
 0.2 mm² (7 / 0.18)

7.3.2 Motor and built-in sensor signal conversion circuit (Cable symbol: K11)

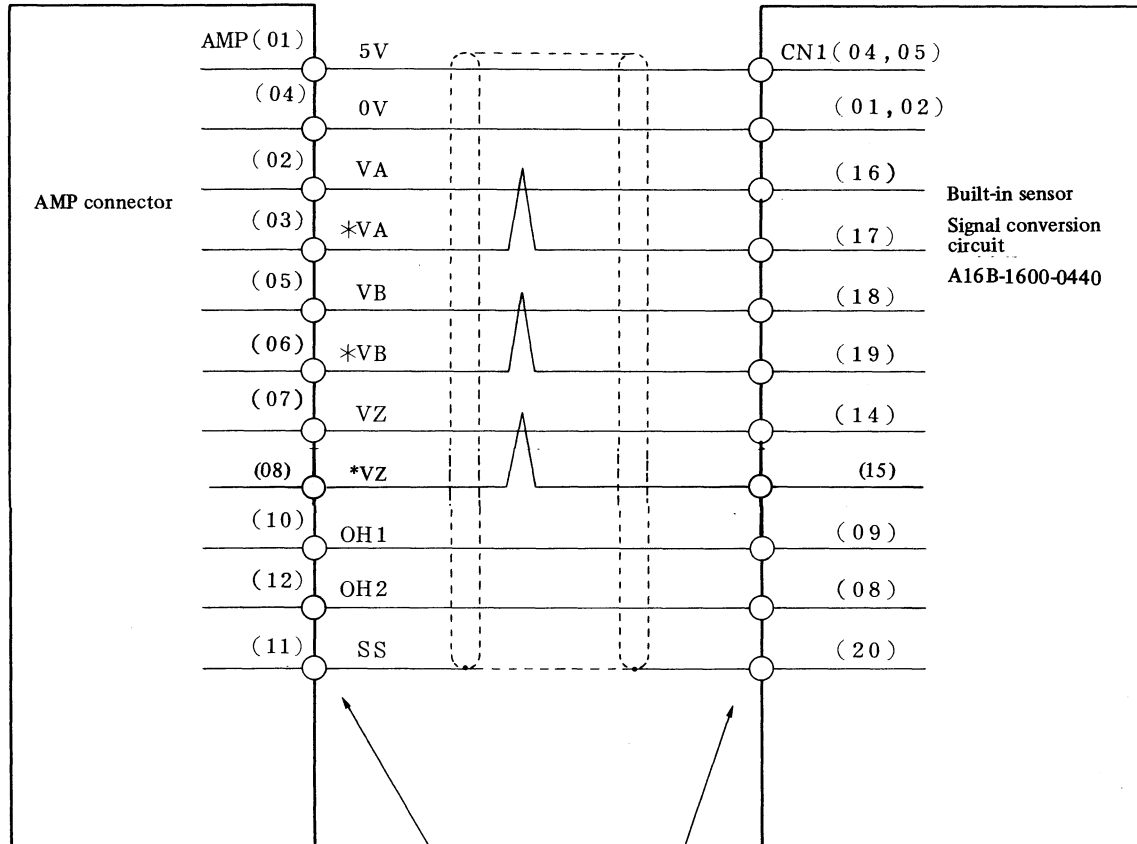

Connectors for use (AMP Japan)
 Plug 350735-1
 Socket 350689-6

Connectors for use (Honda)
 MRP-20F01

Cable for use: 10 pairs of shielded cable
 0.2 mm² (7/0.18)

[Reference] Use the tools listed below for
 pin crimping and welding.

Pin/AMP crimping tool	
Manual tool type number	90300-1
Welding tool	458994-1

- * AMP Manual Tool Operator's Manual; IS 7706
- * When using a manual tool, wire size 22-24 dies

Note) Cable length should be within 7 m.

**7.3.3 Built-in sensor signal conversion circuit and position coder method orientation circuit
(Cable symbol: K02)**

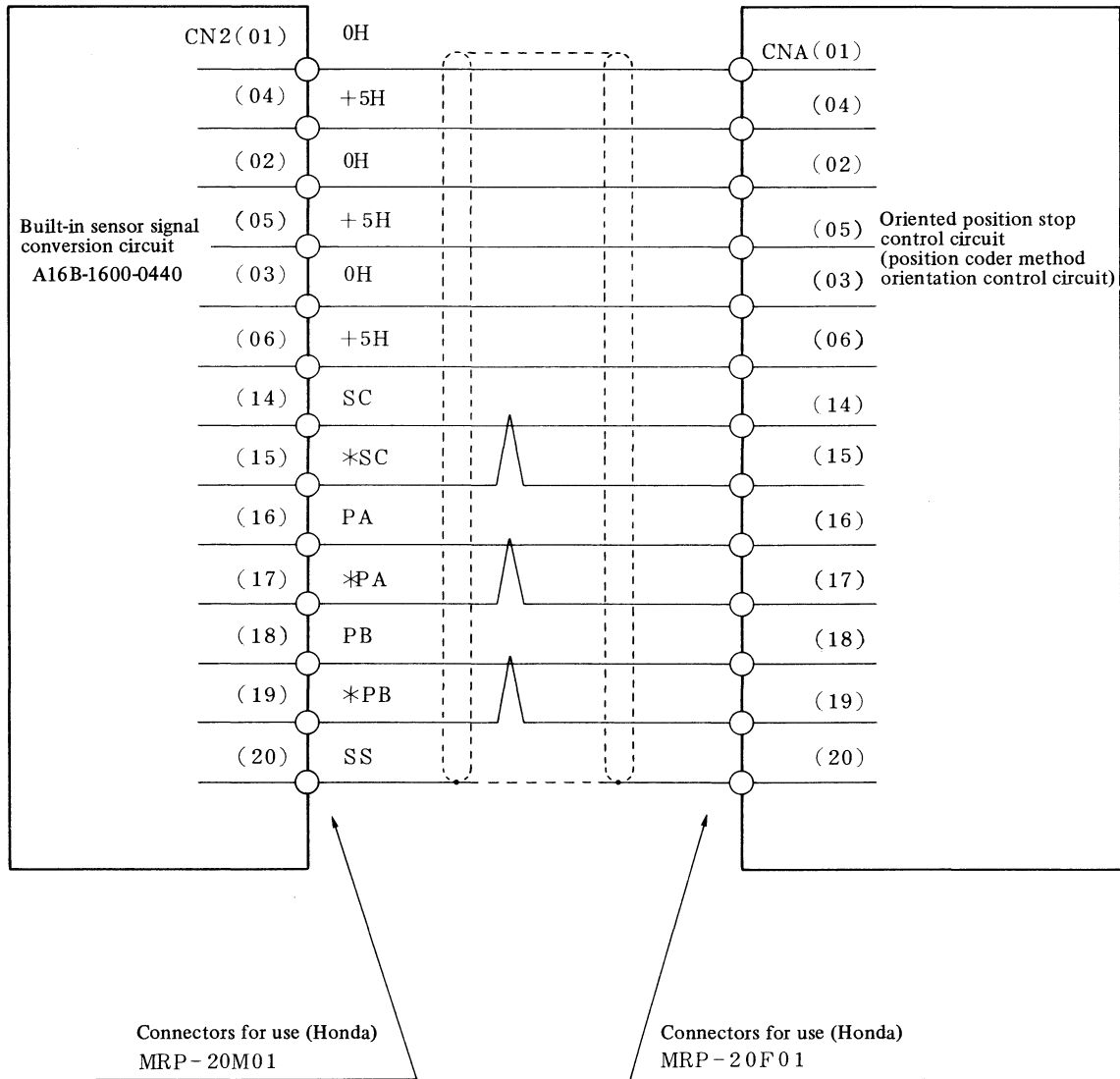

Cables for use: 10 pairs of shielded cable
0.2mm² (7/0.18)

Note) This cable K02 is especially sensitive to noises. It is recommended to use a cable with length of 1 m or less, and connect the shield with pins No. 20 of both connectors.

7.3.4 Built-in sensor signal conversion circuit and AC spindle servo unit
(Cable symbol: K03)

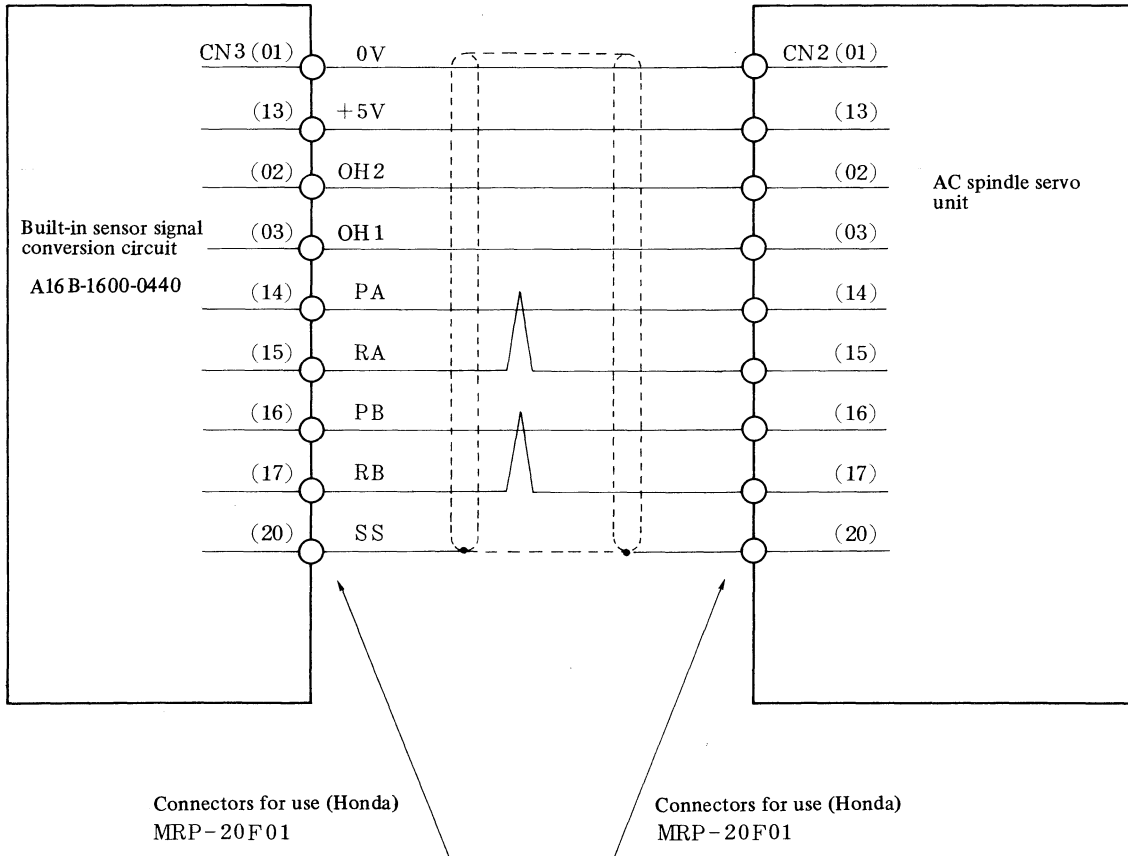

Cables for use: 10 pairs of shielded cables
 0.2 mm² (7/0.18)

Note) Cable length should be within 1 m.

7.3.5 Position coder method orientation circuit and NC (Cable symbol: K04)

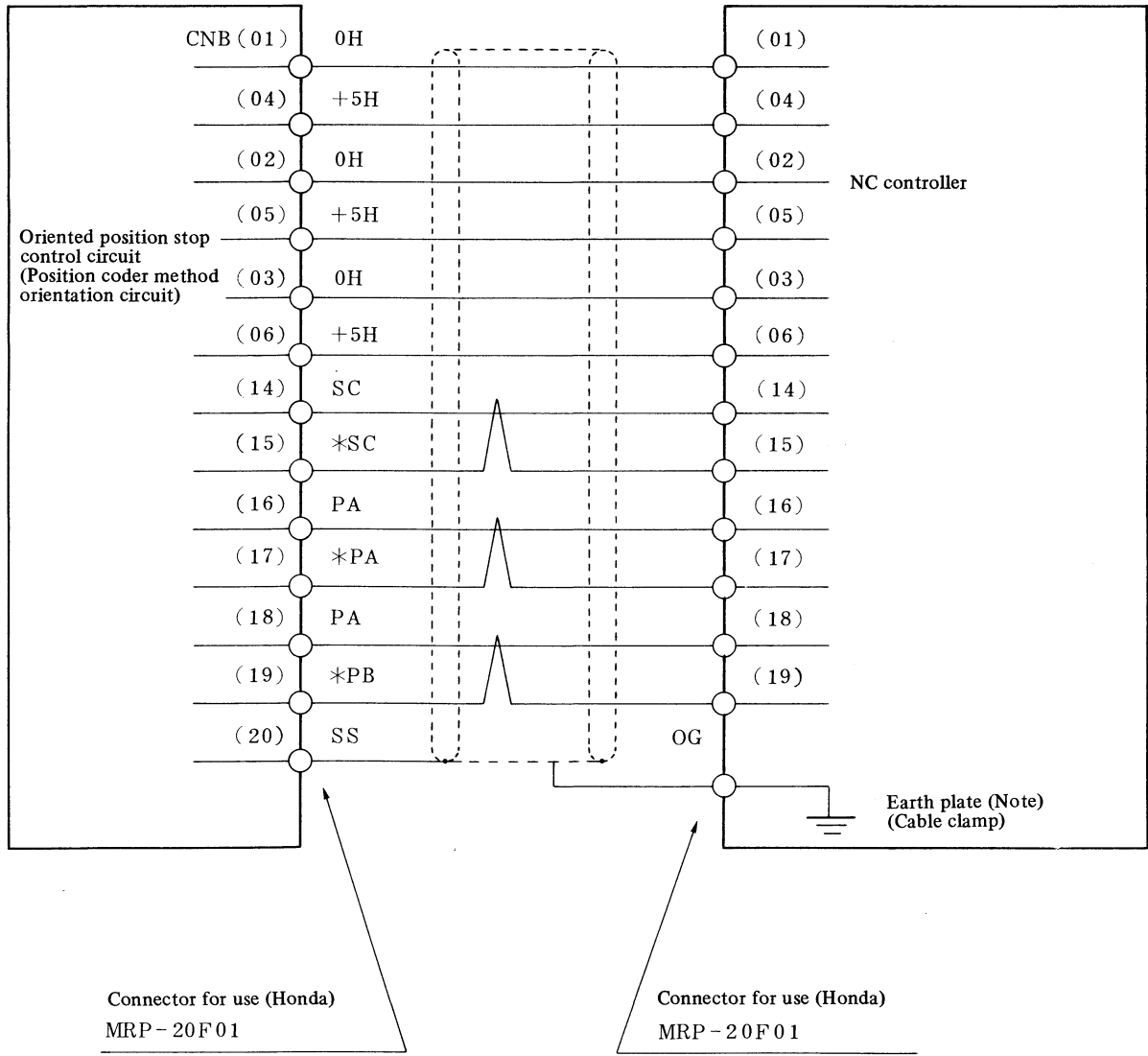

Cables for use: 10 pairs of shielded cables
 0.2mm² (7/0.18)

Note 1) Cable shall be clamped by the clamping metal (A02B-0083-K301)

Note 2) Cable length should be within 14 m.

7.3.6 Built-in sensor signal conversion circuit and NC (Cable symbol: K05)

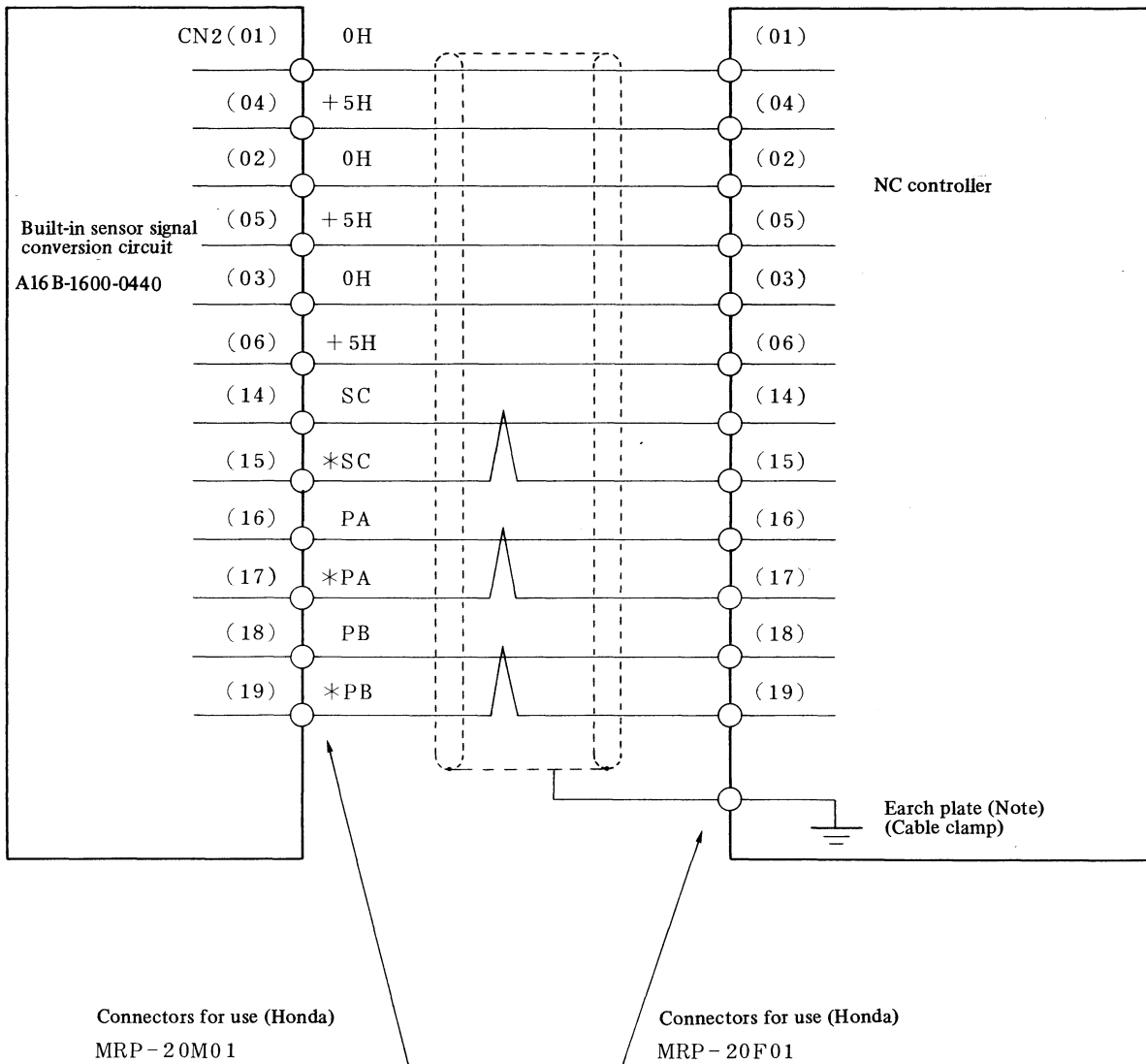

Cables for use: 10 pairs of shielded cables
 0.2mm² (7/0.18)

Note 1) Cable should be clamped by the clamping metal (A02B-0083-K301).
 Note 2) Cable length should be within 14 m.

8. CABLE

8.1 List of Cables

The cable specifications are as follows. These cables should be provided at the MTB.

Applications	Symbol	General specifications	FANUC specification
Built-in sensor signal conversion circuit Oriented position stop control circuit	K02	<p>MRP-20M01 MRP-20F01</p> <p>10 pairs of shielded cable 0.2mm² (7/0.18)</p>	A06B-6059-K800(1m)
Built-in sensor signal conversion circuit AC spindle servo unit	K03	<p>MRP-20F01 MRP-20F01</p> <p>10 pairs of shielded cable 0.2mm² (7/0.18)</p>	A06B-6059-K801(1m)
Oriented position stop control circuit NC device	K04	<p>MRP-20F01 MRP-20F01</p> <p>10 pairs of shielded cable 0.2mm² (7/0.18)</p>	A06B-6059-K802(7m)
Built-in sensor signal conversion circuit NC device	K05	<p>MRP-20M01 MRP-20F01</p> <p>10 pairs of shielded cable 0.2mm² (7/0.18)</p>	A06B-6059-K803(7m)
Built-in sensor AMP plug	K10	<p>Honda connector Z-374 AMP cap 350783-1 Connector HKP-F413 Pin 350706-7</p> <p>8-wire shielded cable 0.2mm² (7/0.18)</p>	A06B-6059-K804(0.5m) A06B-6059-K805(1m)
AC spindle motor or AMP cap Built-in sensor signal conversion circuit	K11	<p>AMP plug 350735-1 MRP-20F01 Socket 350689-6 2003 -T310</p> <p>10 pairs of shielded cable 0.2mm² (7/0.18)</p>	A06B-6059-K806(7m)

8.2 Details of the Cable (K10)

FANUC specification drawing No.: A06B-6059-K804
A06B-6059-K805

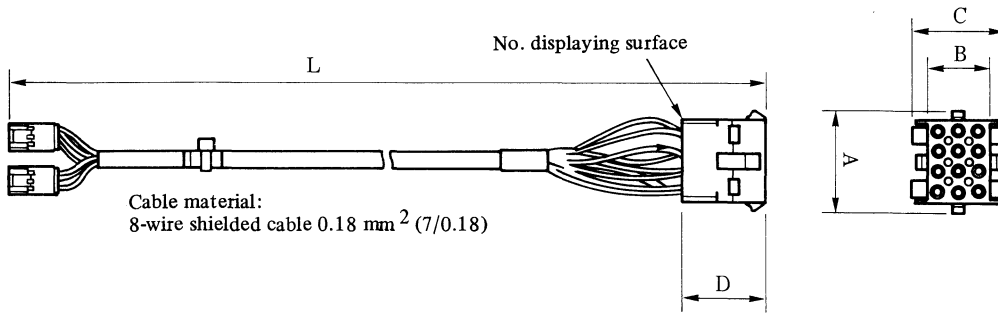

1) Cable dimension

Symbol	Dimension	
	A06B-6059-K804	A06B-6059-K805
A	26.67	26.67
B	20.32	20.32
C	25.91	25.91
D	27.43	27.43
L	500 ₊₂₀	1000 ₊₂₀

2) Detector wire connecting table

1	2	3
Red	Black	Blue
5V	VA	*VA
4	5	6
White/yellow	Green	White/orange
0V	VB	*VB
7	8	9
Gray	White/brown	
VZ	*VZ	
10	11	12
	blue/trans- parent	
OH (Note)	SS	OH (Note)

Note) Connect the OH wire of the motor to Nos. 10 and 12.

3) Accessories

Name	Manufacturer	Model No.	Q'ty
Plug	A.M.P	350735-1	1
Split pin	A.M.P	350706-7	2
Socket	A.M.P	350689-6	10

Reference: Use the tools listed below for crimping and pulling up pins.

Pin/A.M.P crimping tool	
Manual tool type number	90300-1
Tool for pulling up	458994-2

* AMP Manual Tool Operator's Manual: IS 7706

* Use the dies on the wire size 22-24 side for a manual tool.

9. NOTE

1) Adjustment

Adjustment is needed during installation in order to match the built-in sensor with the signal conversion circuit well. For the adjusting method, refer to the maintenance manual corresponding to the spindle servo unit which is currently being used such as FANUC AC SPINDLE SERVO UNIT S series MAINTENANCE MANUAL (Version 03 of B65015E or later) and the like.

2) Built-in sensor system orientation

	No. of detection gear teeth/one rotation	No. of output pulses/one rotation	Detection unit	Repositioning accuracy	
Phase A Phase B	512 teeth/rotation	1024 pulses/rotation	0.088°	$\pm 0.2^\circ$	Note 1
	256 teeth/rotation	1024 pulses/rotation	0.088°	$\pm 0.2^\circ$	
	128 teeth/rotation	512 pulses/rotation	0.176°	$\pm 0.4^\circ$	
	64 teeth/rotation	256 pulses/rotation	0.352°	$\pm 0.8^\circ$	
Phase Z	1 tooth/rotation	1 pulse/rotation	--	--	

Note 1) Error factors due to the machine side are excluded. Movement of ± 1 detection unit occurs at the time of stopping in a specified position by orientation.

Note 2) When the orientation circuit A20B-0008-024* is used, set the orientation rotating direction to counterclockwise using the setting pin SH01 4-13.

3) Take care to observe the following points in order to prevent malfunction caused by noises, drift at the time of orientation stop and the like.

- ① Do not include the signal cable (K10) and the power cable in a same duct.
- ② Make sure to use shielded cables, and connect them to the SS terminals of each connector. (K10, K11, K02 and K03)
- ③ The cables K02 and K03 between the built-in sensor signal conversion circuit and the spindle servo unit are especially sensitive to noises. Therefore the length of the cable should be within 1 m, and keep them apart from power cables.
- ④ If grounding of the spindle servo unit or the motor is not sufficient, noises may be mixed with feedback signals, speed command voltage and the like, and it may occur drift at the time of orientation stop, irregular rotation, queer sounds and the like. Connect the grounding cables referring to the corresponding part in this manual.

4) Grounding

- ① Connect the G terminal of the machine power panel to that of the spindle servo unit.
- ② Connect the G terminal of the spindle servo unit to that of the spindle motor.
- ③ Connect the G terminal of the spindle servo unit as close as possible to the frame of the power panel.

Reason) If the cable is apart from the G terminal of the power panel, there is a possibility of insufficient grounding.

- ④ Connect the G terminal of the machine power panel with the external grounding cable.

Note 1) Connect the G terminal of the machine power panel with a terminal grounded in conformity to the third section "Insulating/grounding a cable way" of "TECHNICAL STANDARDS FOR ELECTRICAL EQUIPMENT."

Note 2) Use cables with sufficient thickness (5.5 mm^2 or more) to connect the G terminal of the CNC control circuit and the grounding terminal, and the grounding terminal and the G terminal of the machine power panel. Also, connect them as close as possible.

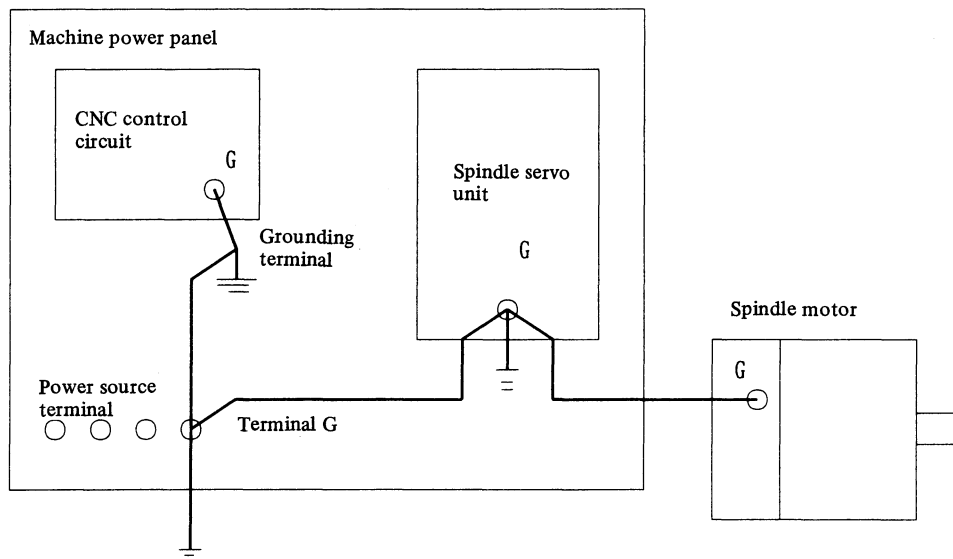

- 5) When performing threading or rigid tapping by means of built-in sensor which is built in the motor, and in the case of a machine tool of which the spindle and the motor are linked by gear or belt, a deterioration of the accuracy of screws may occur due to gear backlash or expansion of the belt.

[Backlash]

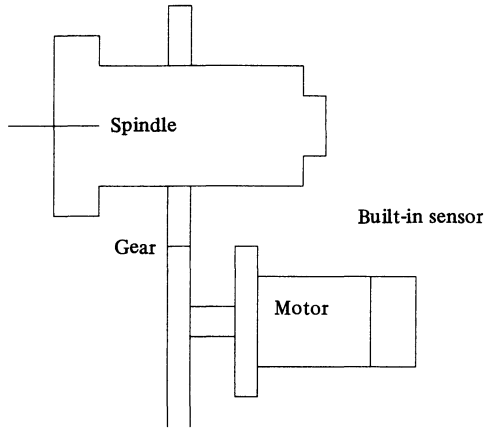

[Expansion of belt]

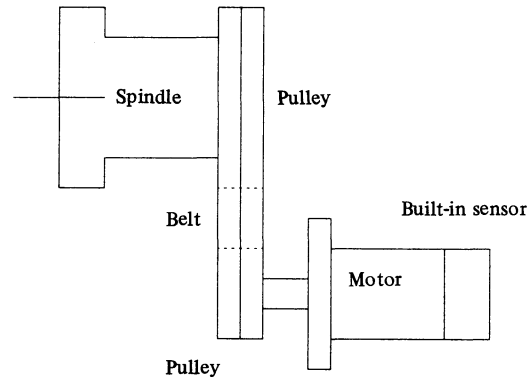

When a backlash of 1 mm is produced on the circumference of the gear of $\phi 100$, an error of rotation angle $1/(2\pi \times 100) \times 360^\circ = 0.573^\circ$ will generate at the bottom of the screws during rigid tapping.

- 6) When performing orientation by means of built-in sensor which is built in the motor, and in the case of a machine tool of which the spindle and the motor are linked by gear or belt, it is impossible to execute orientation.

- 7) The built-in sensor which generates signals same as that of position coder can be mounted in the motor. Numbers of pulses for models 1S - 3S are 512 p/rev, and for models 6S - 22S are 1024 p/rev.

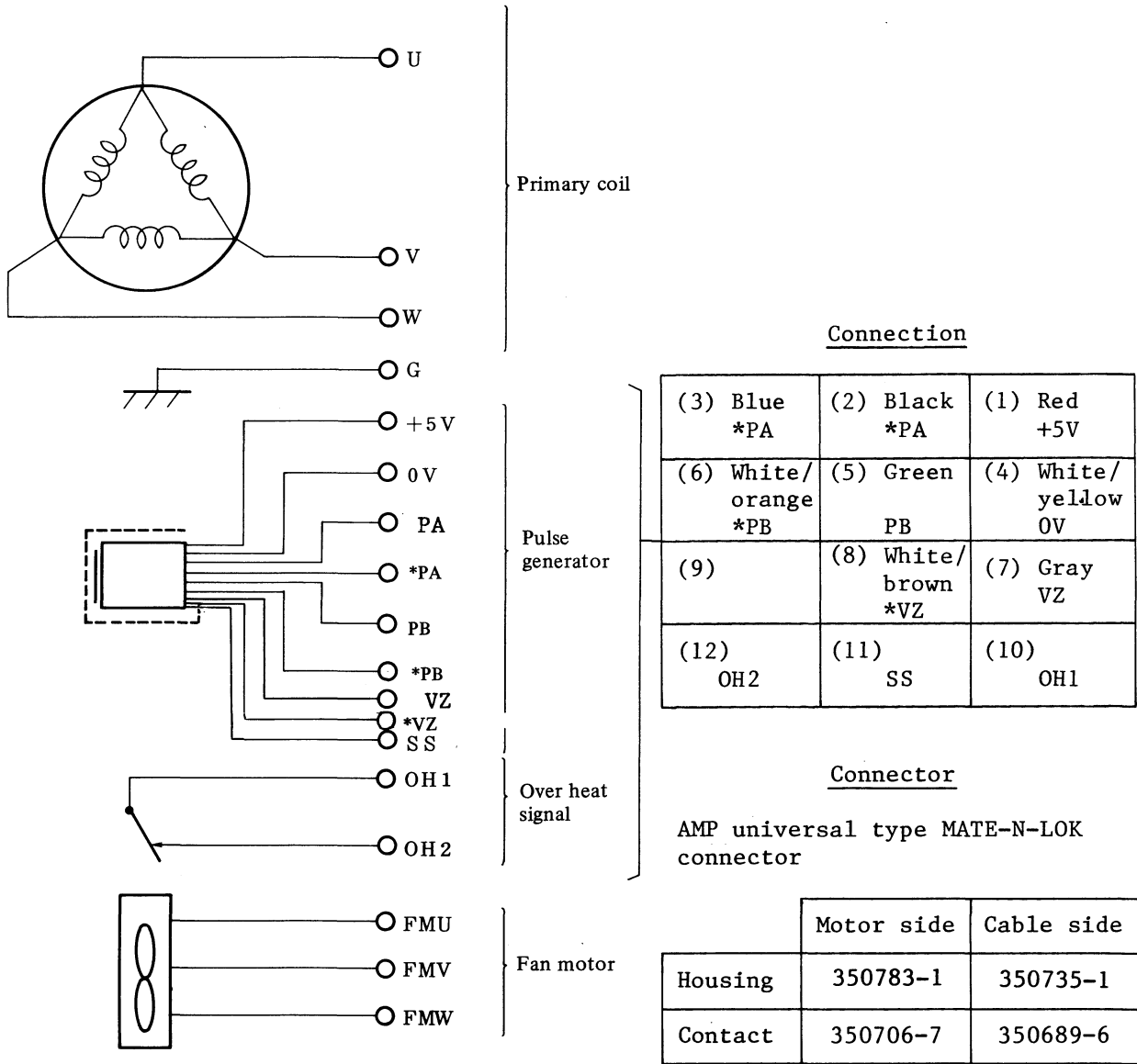

Signals of pulse generator and over heat are connected to AMP connector. Others are connected to terminals. AMP connector and contact are attached to the motor.

8) Regarding the built-in sensor method spindle orientation

No.	Item	Specifications	
		Type A (A860-0390-T002)	Type B (A860-0390-T004)
1	Allowable maximum revolution	10000 rpm	10000 rpm
2	Output of built-in sensor signal conversion circuit	A phase 1024 pulse/revolution B phase 1024 pulse/revolution Z phase 1 pulse/revolution	A phase 512 pulse/revolution B phase 512 pulse/revolution Z phase 1 pulse/revolution
3	Detecting unit	360°/4096 pulse = 0.088°/pulse	360°/2048 pulse = 0.176° pulse
4	Repeated positioning accuracy	$\pm 0.2^\circ$	$\pm 0.4^\circ$
		Note) However, element of error by machine's side is excepted. Movement of 2 detecting units may occur at the time of oriented position stop by orientation.	

VIII. OUTPUT CONVERSION CONTROL

1. GENERAL

Output conversion control conducts control of output characteristic conversion in one motor (motor designed specifically for output conversion control) using the FANUC AC spindle servo unit S series.

2. COMPONENTS AND ORDER DRAWING NUMBER

2.1 Components

The following items are needed in addition to the FANUC AC spindle servo unit S series.

- 1) Output switching control circuit
- 2) Relay circuit (including electromagnetic contactor and drive relay)
- 3) Conversion signal from PMC

Configuration of the components is shown in the figure below.

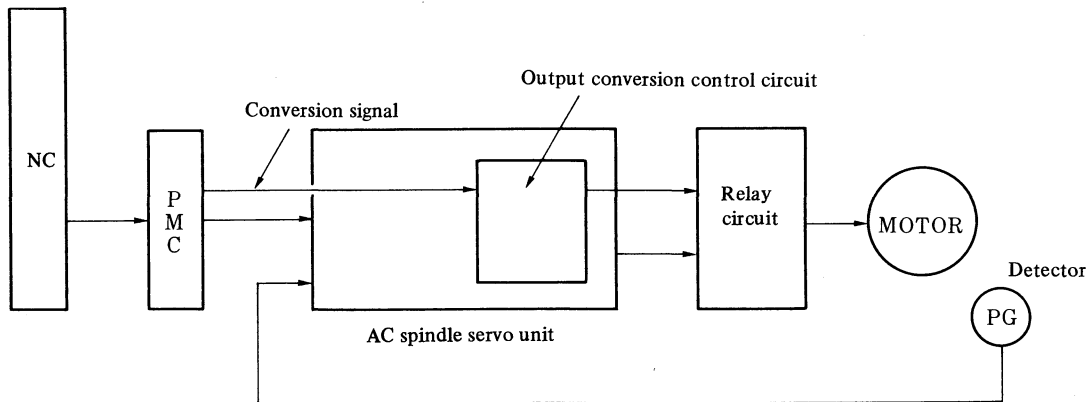

The machine tool maker is required to provide the relay circuit and conversion signal.

2.2 Order Drawing Number

- 1) AC spindle servo unit

A06B-6059-H000# H000

Specified numbers vary with specifications

- 2) Output conversion control circuit

A06B-6059-J703

3. SPECIFICATIONS

In order to conduct output conversion control, the AC spindle servo unit S series, an output conversion control circuit and a relay circuit are required. As specifications of the AC spindle servo unit used for output conversion control varies with different motors, be sure to refer to the specification manuals of each relevant AC spindle motor used for output conversion control.

* Precautions related to finishing when the output conversion control circuit is provided with the AC spindle servo unit S series

- 1) The spindle conversion control circuit can not be added.
- 2) As the speed detecting signal (SDT1,2) is used for output conversion speed detection, it cannot be used for gear conversion speed detection etc.
- 3) The spindle high/low speed signal (CTH) is used as a power cable conversion completion signal, and therefore, can not be used as a signal for gear selection status.
- 4) The spindle orientation circuit and speed gain conversion circuit can be used even when the output conversion control circuit is included.

4. EXTERNAL DRAWING

For items other than those given below, refer to Chapter II of this specification manual.

4.1 AC Spindle Servo Unit S Series (when an output switching control circuit is mounted)

4.1.1 AC spindle servo unit models 6S - 12S (without unit adaptor)

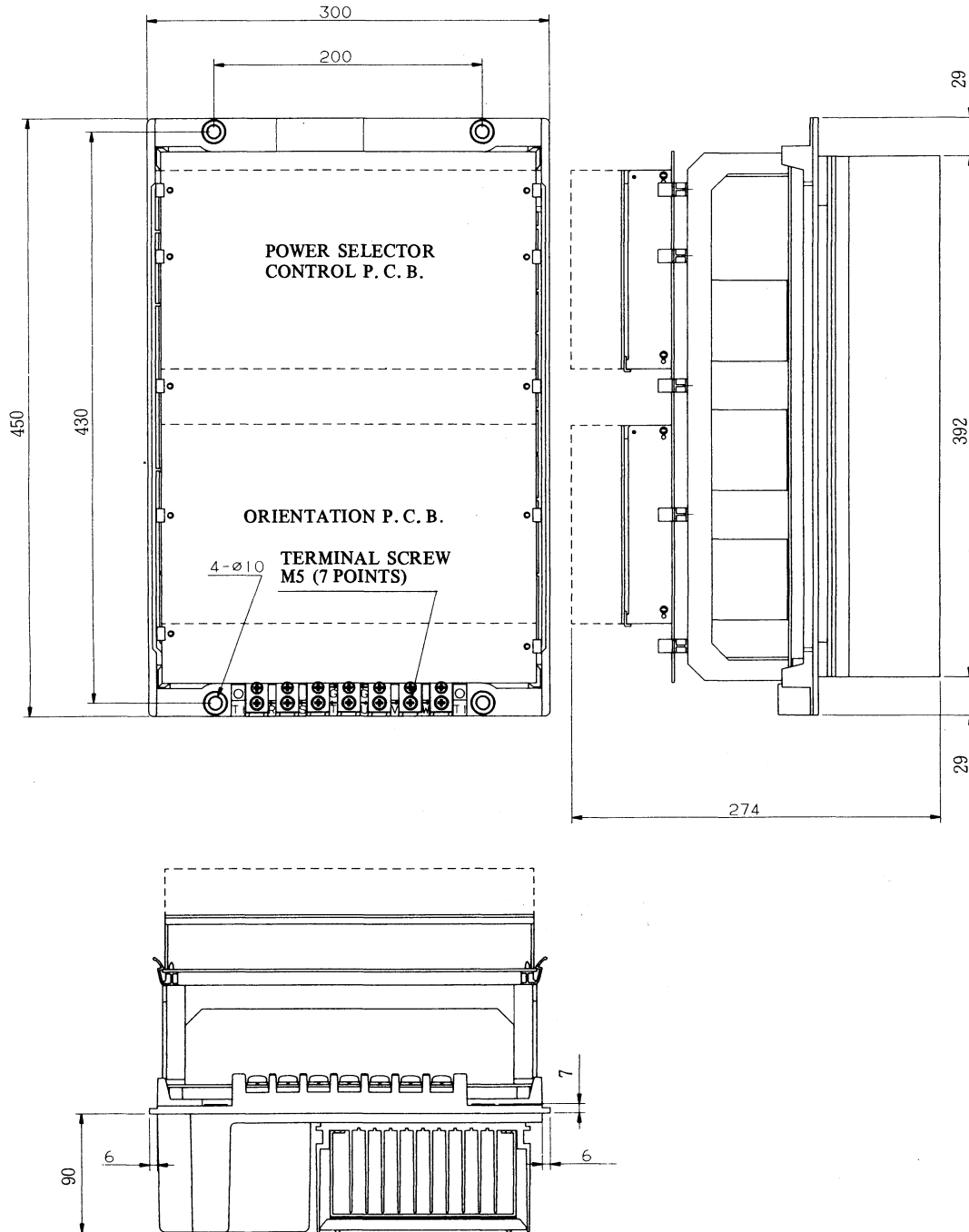

4.1.2 AC spindle servo unit models 15S - 22S (without unit adaptor)

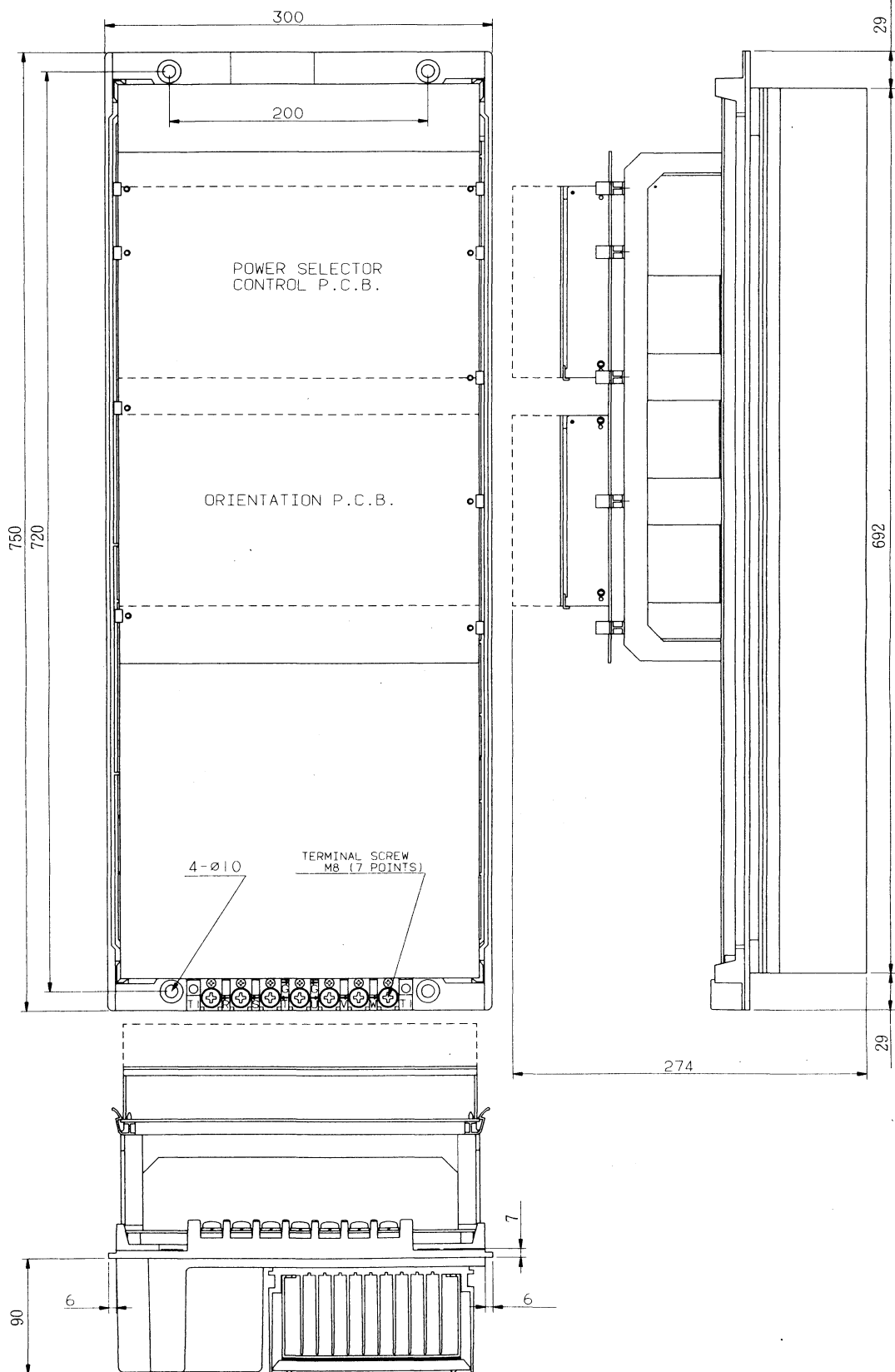

4.1.3 Outline drawing of the output conversion control circuit

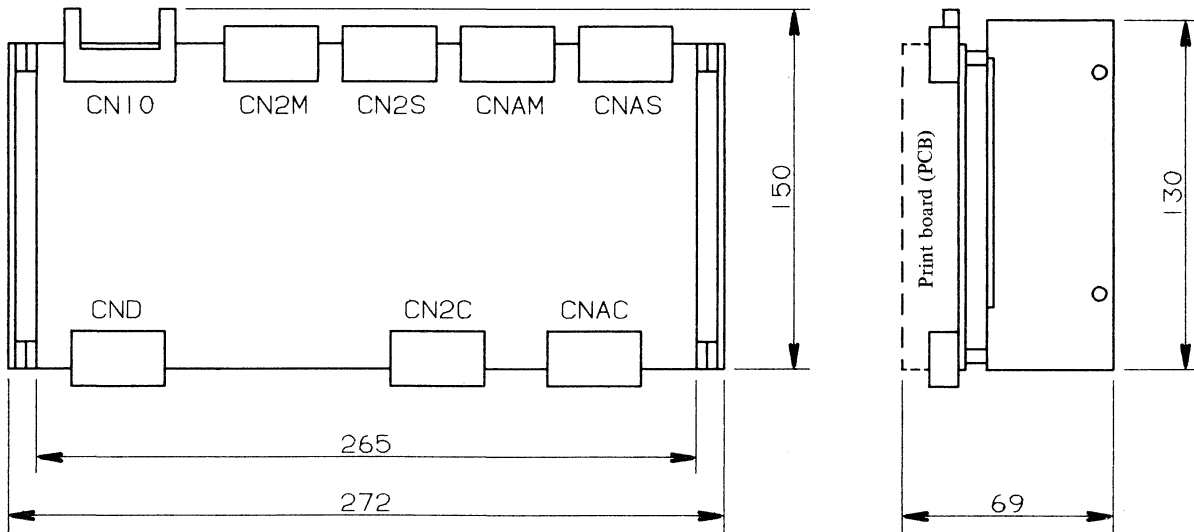

5. INSTALLATION

Refer to Chapter II of this description manual.

In addition, forced cooling is required for this AC spindle servo unit S series.
We will contact you separately about details related to cooling conditions.

6. CONNECTION

6.1 a) Connection Diagram (Type A)

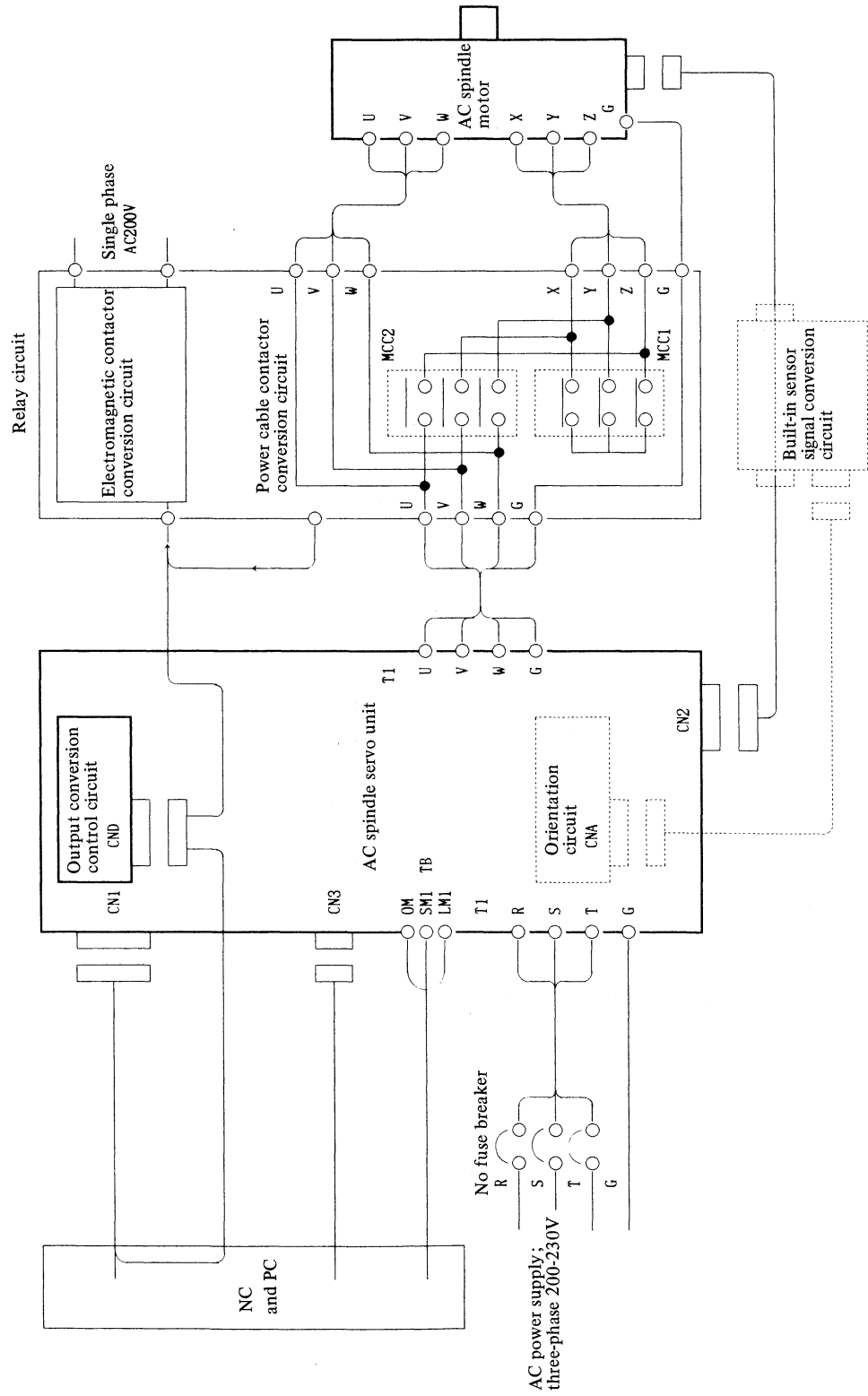

Items such as units and cables other than the AC spindle servo unit, output conversion control circuit and AC spindle motor, which are surrounded by the unbroken line, must be provided by the machine tool builder.

6.1 b) Connection Diagram (Type B)

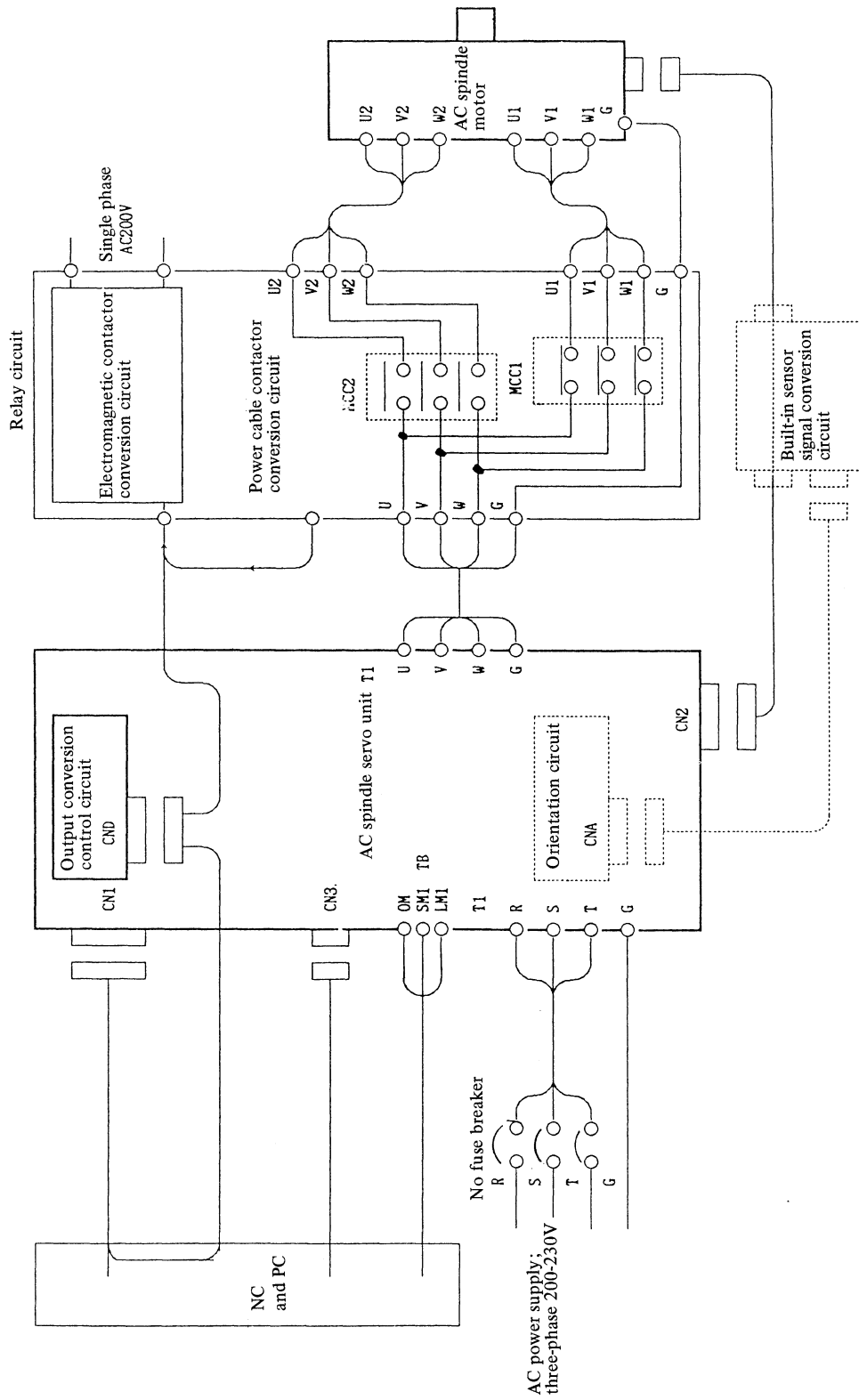

Units and cable other than the AC spindle servo unit, output conversion control circuit and AC spindle motor, which are surrounded by the unbroken line, must be provided by the machine tool builder.

6.2 Connectors

For details related to connectors other than the below-described CND and CN1 used with the output conversion control circuit, refer to Chapter II of this specification description manual.

1) CND specifications and signal layout drawing

14	CHP1			01	SEL1	
15	CHP2	08		02	SEL2	
16	CFIN1	09		03	MCF1	Print board (PCB) connector MR-20MA
17	CFIN2	10		04	MCF2	
18		11		05		PMC connector MR-20LFH
19		12		06		
20	SS	13		07		

2) CN1 specifications and signal layout drawing

33				01	SAR1		
34				02	SAR2		
35		19	ARST1	03	SST1	Print board (PCB) connector MR-50RMA PMC connector MR-50LFH	
36		20	ARST2	04	SST2		
37		21	TLMH	05	TML		
38		22	ORAR1	06	OT		
39		23	ORAR2	07	MRDY1		
40		24	CTM	08	MRDY2		
41		25	ORCM1	09	TLM5		
42		26	ORCM2	10	TLM6		
43		26	OVR1	11	ALM1		
44		28	OVR2	12	ALM2		
45	SFR	29	+15V	13	OR		
46	SRV	30		14	OS		
47	ESP1	31	DA2	15	SDT1		
48	ESP1	32	E	16	SDT2		
49	LM1			17	CTH		(Connect CFIN1)
50	SM1			18	OM		(Connect CFIN2)

* Definition of numbers 17 and 18 are different.

7. EXPLANATION OF INTERFACE SIGNAL

For details about signals other than those described below, refer to Chapter II of this specification description manual.

Also, refer to section 7.2 and thereafter for details about connector CND which is not described in this specification description manual and connector CN1 number 17 and 18 pins, whose signal definition is different.

7.1 Input Signals

7.1.1 Conversion demand signal (SEL1, 2)

This signal is input to change the characteristics of output. The following are selected by opening and closing connections.

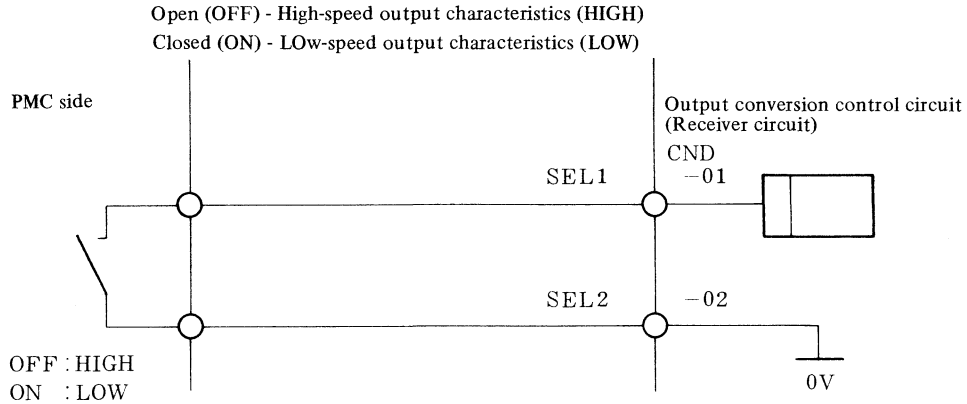

7.1.2 Power cable status confirmation signal (MCF1, 2)

This signal is input to confirm the selection status of the electromagnetic contactor used for spindle motor output conversion.

The following are selected by opening and closing connections. For details, refer to the Chapter 9.

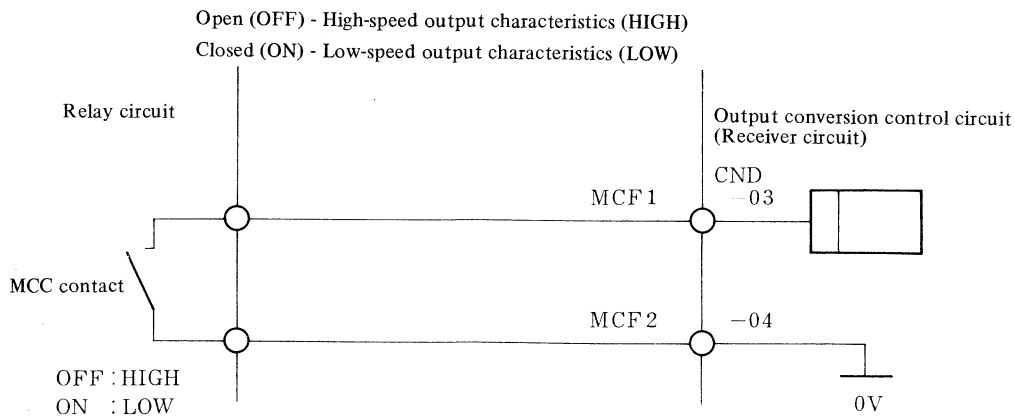

7.2 Output Signals

7.2.1 Speed detection signal (SDT1, 2)

This is used at the time of detecting converted speed when conducting output conversion.

(OFF) - converted speed or higher

(ON) - converted speed or lower

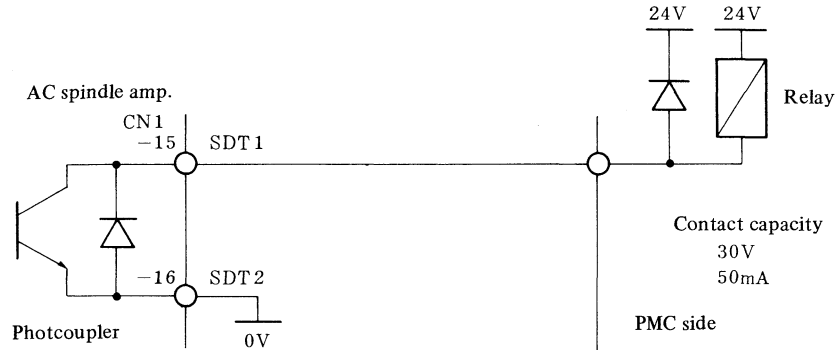

7.2.2 Power cable conversion signal (CHP1, 2)

The conversion demand signal (refer to section 7.1.1) to the output conversion control circuit causes power supply to the motor to be switched OFF. Status of this signal changes when the power is switched OFF. Therefore, conduct conversion of the electromagnetic contactor to convert the power cables following the order shown in signals (3), (4), (5) in "8. SEQUENCE". For details, refer to the connecting example in the Chapter 9.

Select as follows using ON/OFF of this signal:

(OFF) - High-speed output

(ON) - Low-speed output

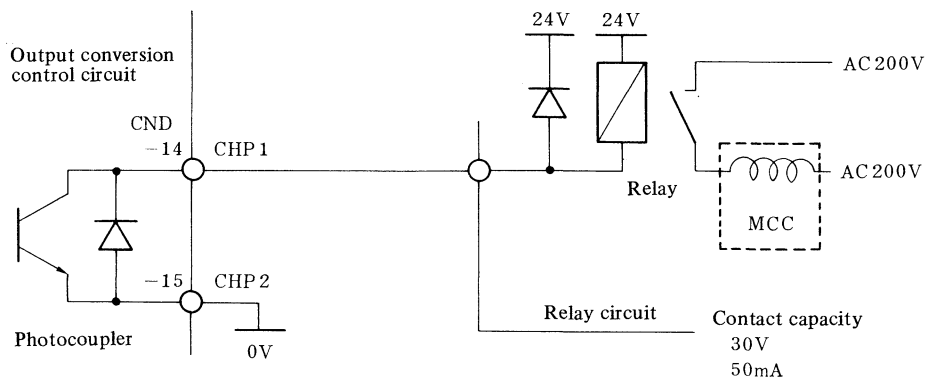

7.2.3 Conversion completion signal (CFIN1, 2)

After the output conversion demand signal has been input, the power cable status confirmation signal is input to confirm conformity of selection status, then this signal is output when the initial setting of the spindle control circuit is completed and the next action becomes possible.

By ON/OFF of this signal, the following selection statuses of the spindle are displayed.

(OFF) - high-speed output (HIGH)

(ON) - low-speed output (LOW)

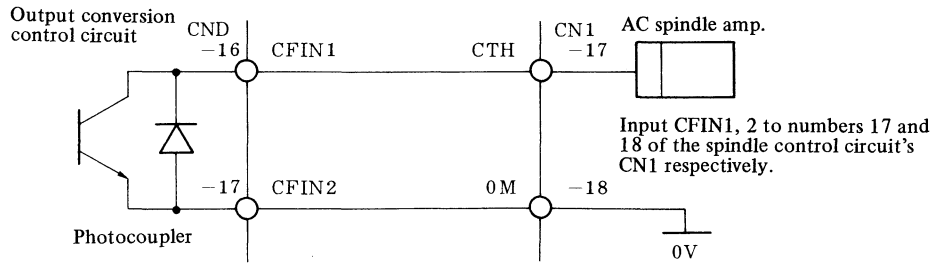

8. SEQUENCE

8.1 Low-speed Output (LOW) - High-speed Output (HIGH)

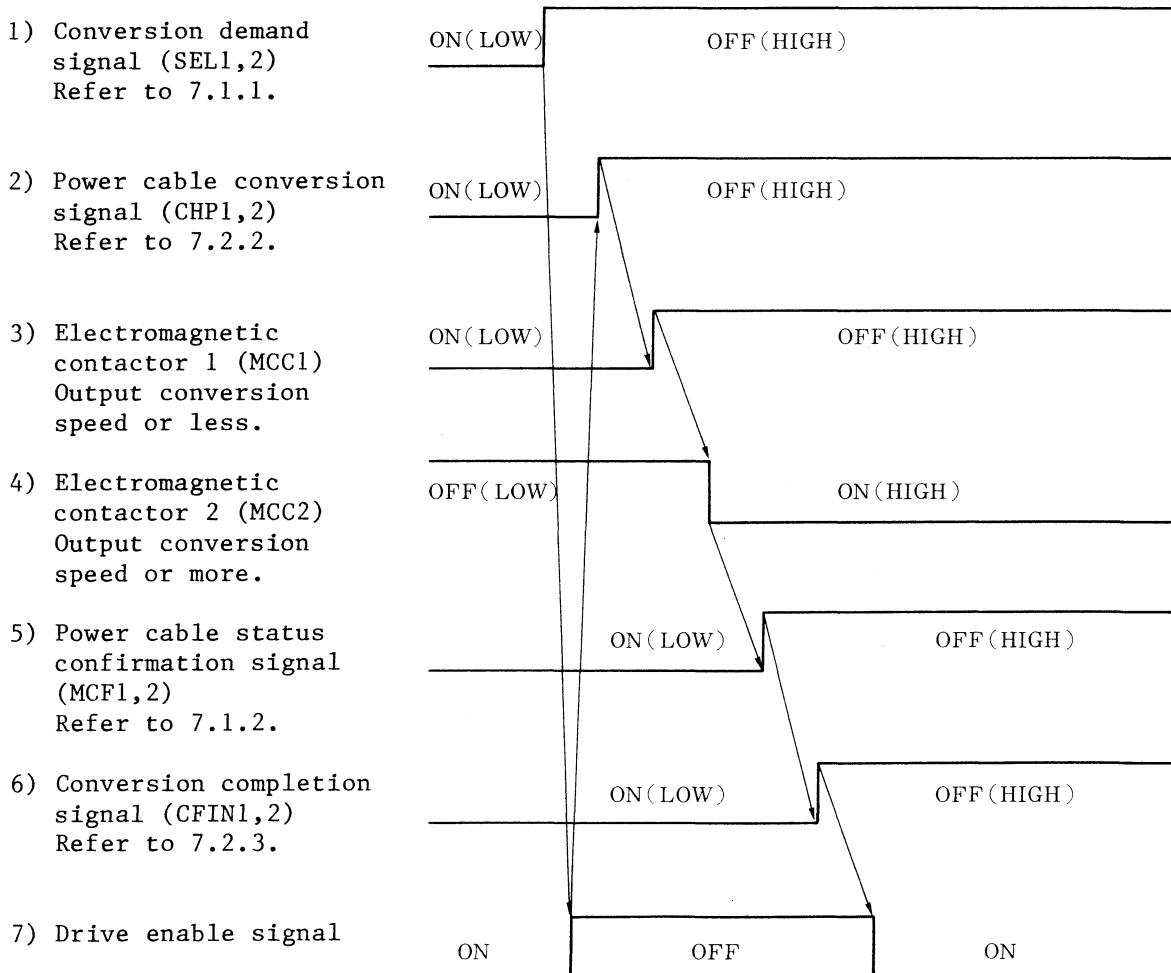

8.2 High-speed Output (HIGH) - Low-speed Output (LOW)

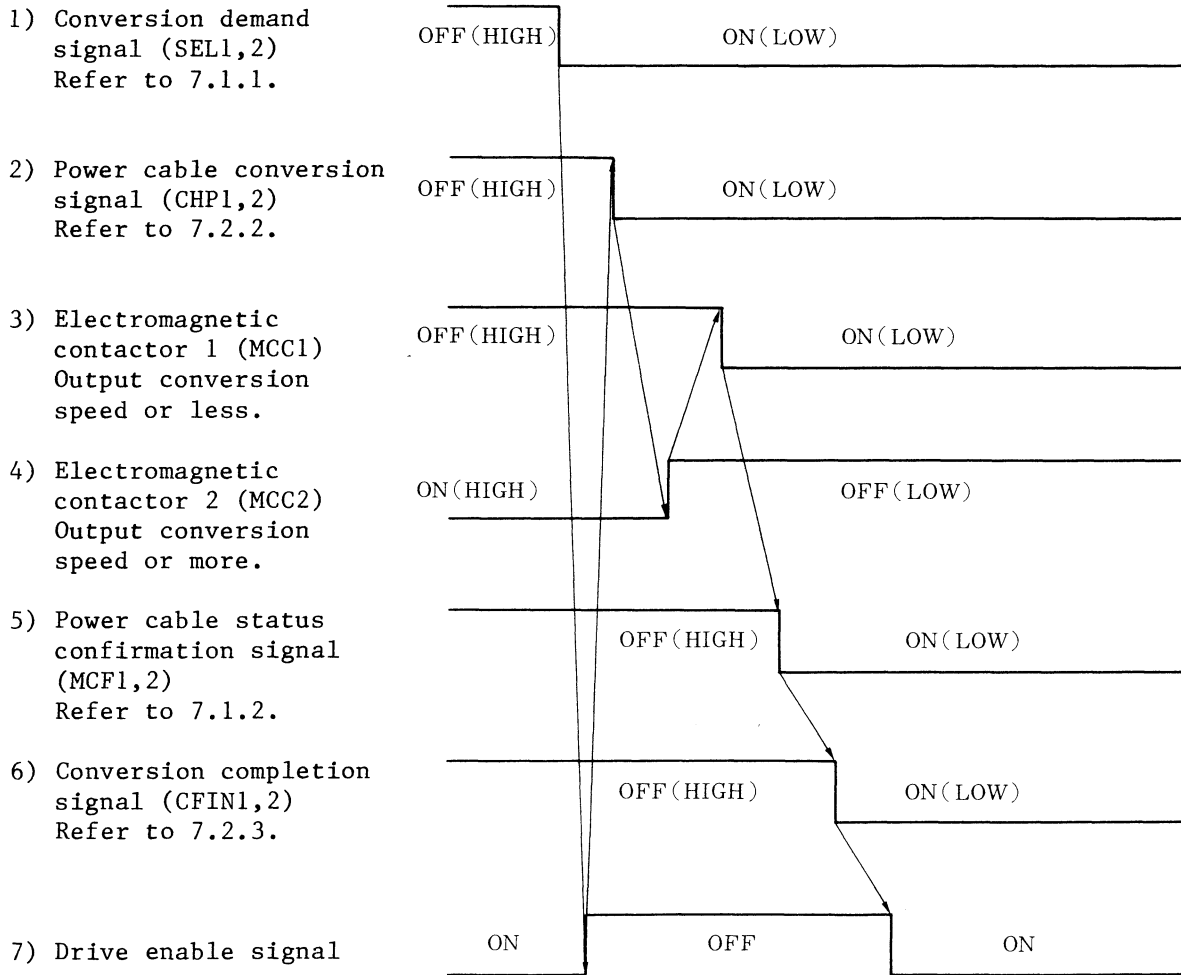

Warning) When converting from high-speed output to low-speed output, conversion demand exceeding conversion speed can not be input.

9. EXAMPLE CONNECTION FOR THE ELECTROMAGNETIC CONTACTOR SWITCHING CIRCUIT

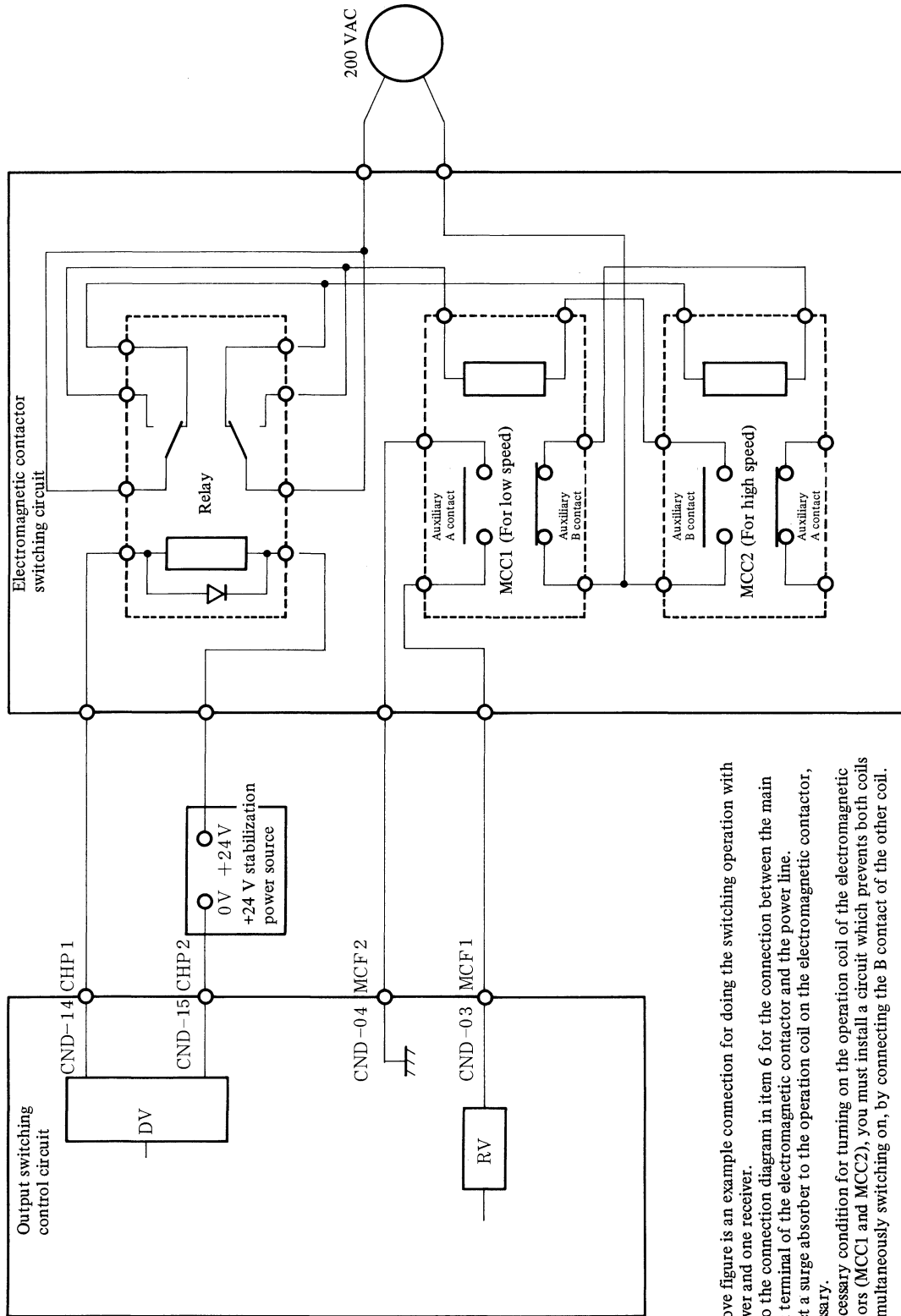

- Note 1: The above figure is an example connection for doing the switching operation with one driver and one receiver.
- Note 2: Refer to the connection diagram in item 6 for the connection between the main contact terminal of the electromagnetic contactor and the power line.
- Note 3: Connect a surge absorber to the operation coil on the electromagnetic contactor, if necessary.
- Note 4: As a necessary condition for turning on the operation coil of the electromagnetic contactors (MCC1 and MCC2), you must install a circuit which prevents both coils from simultaneously switching on, by connecting the B contact of the other coil.

10. PRECAUTIONS RELATED TO USE

- 1) Use an electromagnetic contactor for output conversion that has an adequate capacity.

The example given below shows model ratings of Fuji Electric Co., Ltd.

Applicable kVA	Electromagnetic contactor model ratings
12 kVA	SRCa3631-2
22 kVA	SC-2S
26 kVA	SC-3
32 kVA	SC-4
37 kVA	SC-4S

- 2) As a photocoupler is used for signal output, polarity exists. Take adequate care in relation to polarity of the contact circuit.
- 3) Maximum voltage that can be applied to the photocoupler is 30 V, and maximum current is 50 mA. Be sure to avoid exceeding these maximum values.
- 4) In order to suppress electrical noise generated at conversion in the electromagnetic contactor for output conversion, use a surge absorber built into the resistor-condensator.
- 5) When conducting rigid tapping, set the desired output characteristics in advance and do not perform conversion.
Accordingly, when conducting rigid tapping, although the high-speed detection signal will be output from the AC spindle servo unit, but be sure that this signal is ignored and that the conversion demand signal is not transmitted to the output conversion control circuit.
- 6) Setting the machine ready signal (MRDY1-2)
For the purpose of safety, two signals have been included in the sequence to operable status. These are the emergency stop signal (ESP1,2) and machine ready signal (MRDY1-2).
In other words, close the machine ready (MRDY1-2) contact to allow operation of the machine.
At this time, set parameter F-01 to "1".
- 7) Speed detection signal (SDT1,2) and selection signal (SEL1,2)
Two coils are installed within the AC spindle motor. By switching these two coils, output characteristics can be converted.
When conducting output conversion during rigid tapping, control may be limited to the high-speed coil.
Ensure a sequence in the PMC that allows selection of 2 output characteristics and enable selection of a conversion sequence during rotation.

IX. SPINDLE SWITCHING CONTROL CIRCUIT

1. OUTLINE

Main spindle selector control enables changing over between two spindle motors, which are not driven simultaneously, with identical characteristics or with different output characteristics.

In this control one AC spindle servo unit has to have a printed-circuit board for main spindle selector control circuit and an electromagnetic contactor for selecting power lines outside the servo unit.

- 1) In turning centers, the main spindle motor for main turning and the subspindle motor for rotary tool are used by changing over the signal lines for power lines and velocity feedback and the orientation signal lines with one spindle unit.
- 2) In five-surface working machines, the vertical spindle motor and the horizontal spindle motor are used by changing over the power lines and velocity feedback signal lines and the orientation signal line with one spindle unit.

2. CONFIGURATION AND ORDER SPECIFICATION

2.1 Configuration

For the control of 2 motors by a single servo unit the following items are required in addition to the AC spindle motor and AC spindle servo unit.

- 1) Spindle selector control circuit (Option)
- 2) Power lines selector relay circuits (including electromagnetic contactors and drive relay)
- 3) Selection signal from power magnetic sequence

The system configuration is shown below.

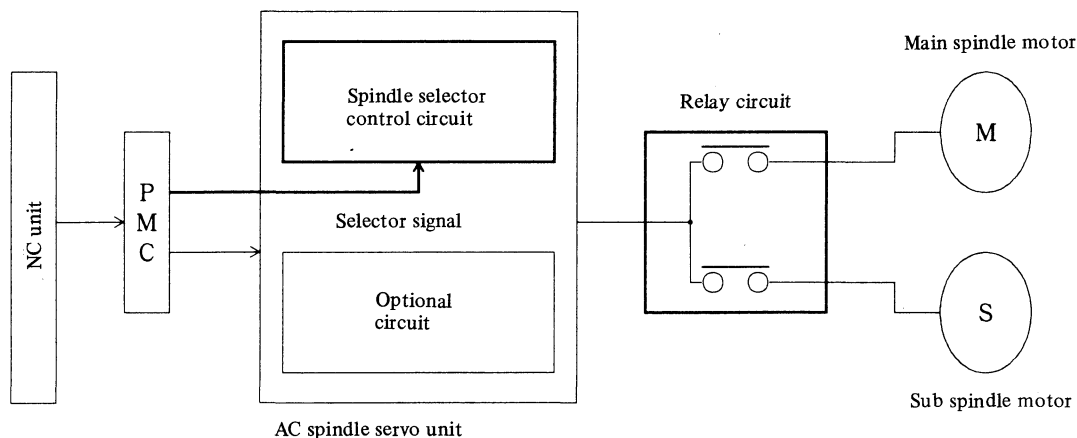

2.2 Order Specification

1) AC spindle servo unit

A06B-6059-H000#H700



Main spindle motor Appointment varies according to
unit number main/sub combination

SUB MAIN	M1S 8000	M1.5S 8000	M2S 8000	M12S 6000	M15S 6000
M22S 6000	/	/	H737	H741	/
M18S 6000	/	/	H728	/	/
M15S 6000	/	/	H720	/	H725
M12S 6000	H711	H712	H713	/	/
M8S 6000	H705	H706	H707	/	/
M6S 6000	H700	H701	H702	/	/

SUB MAIN	M1S 8000	M2S 8000
M22P 6000 rpm (AMP:15S)	/	H763
M18P 6000 rpm (AMP:12S)	H757	/
M15P 6000 rpm (AMP:8S)	H753	/
M12P 6000 rpm (AMP:6S)	H749	/

(*1) It is impossible to specify the shaded area in the table above or combinations which are not found in it.

2) Spindle selector control circuit

A06B-6059-J701 (Without orientation signal line selection)

A06B-6059-J702 (With orientation signal line selection)

The above is selected according to whether the orientation circuit is used.

3. SPECIFICATIONS

- . When spindle selection control is required the AC spindle servo unit S series will need a spindle selector control circuit and, externally, a relay circuit.
- . The spindle selector control circuit fulfills the following functions.
 - 1) Transfer of motor selector demand and completion signals
 - 2) Transmission of motor power line selector signals
 - 3) Selector of velocity feedback signal lines
 - 4) Selector of orientation signal lines
(That both for Magnetic Sensor and for Position Coder can be changed over.)
 - 5) Protection and malfunction detector functions
 - ① In the case of changing over a power line status confirmation signal while the AC spindle motor is in operation that is treated as a malfunction, the alarm operates and the power supply from the AC spindle servo unit to the AC spindle motor is instantly cut off.
 - ② Whether the selected spindle motors and control circuits are the correct combinations is constantly checked by the power line confirmation status signal and the alarm operates in the case of any malfunctions.
- . Even where a spindle selector circuit is already fitted, the spindle orientation circuit and velocity gain selector circuit may still be used.

4. OUTER DIMENSIONS

4.1 Spindle Switching Control Circuit

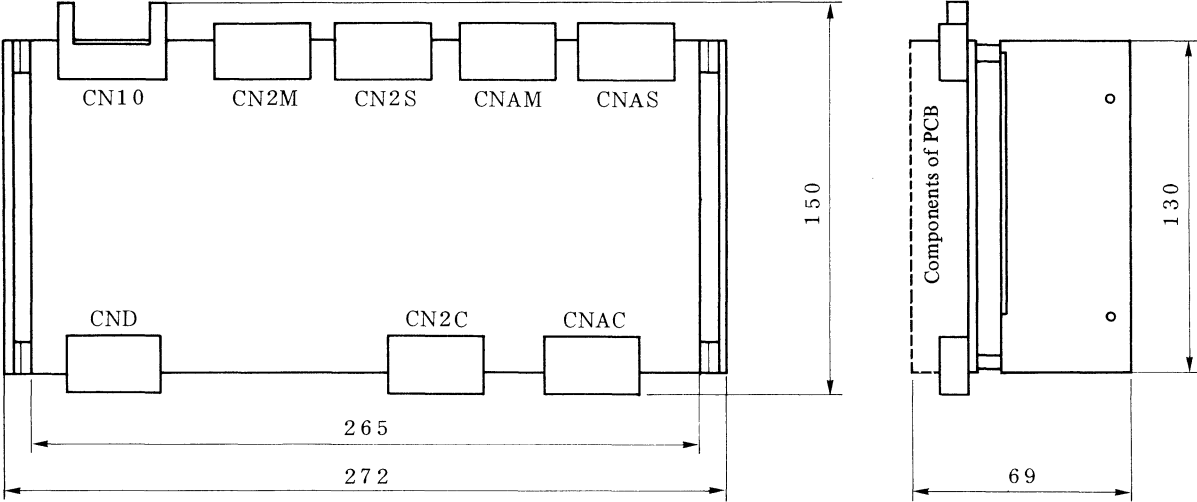

5. CONNECTIONS

5.1 Connections

The spindle selector circuit is installed in the AC spindle servo unit.

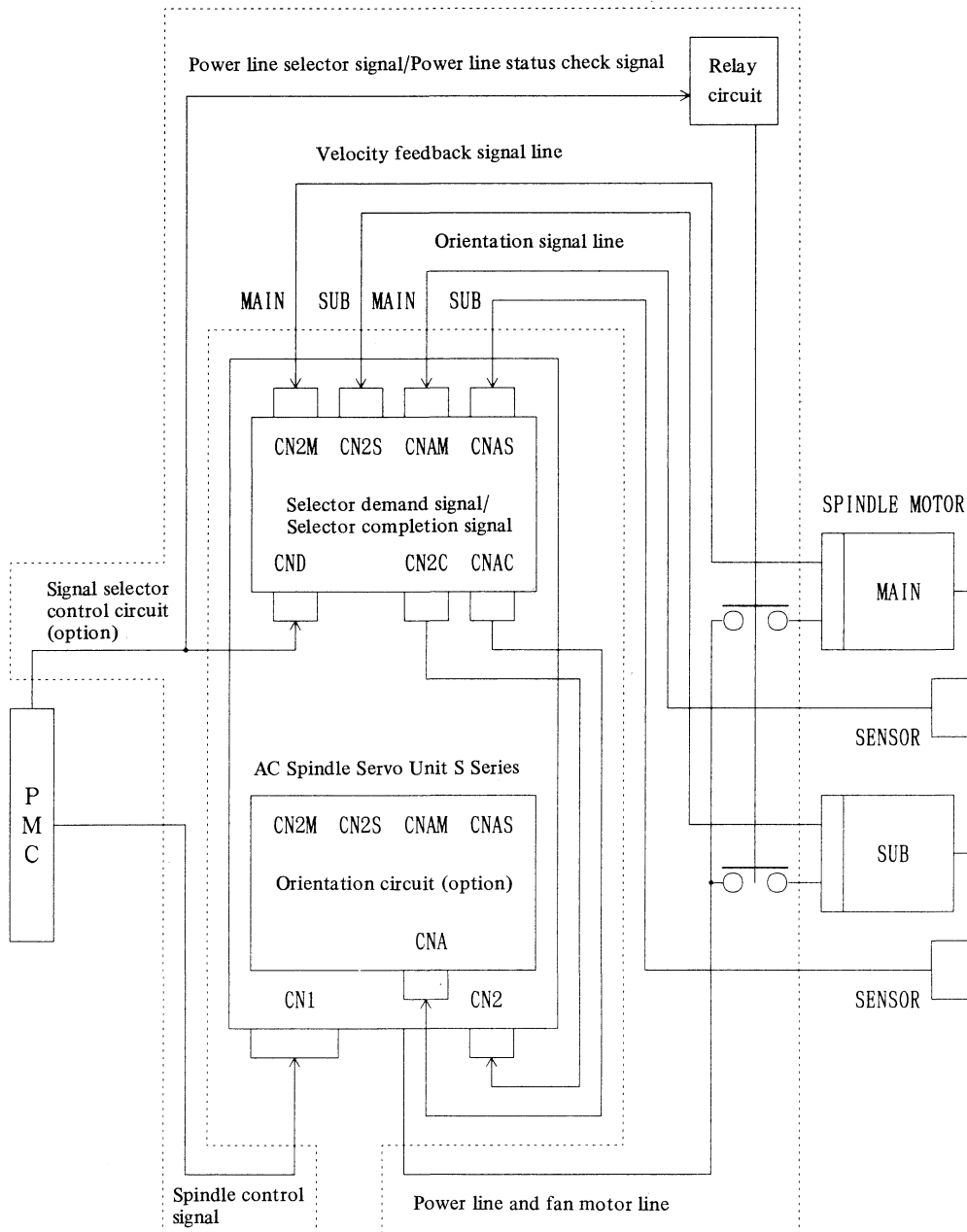

Note) The power lines, cables, relay circuits and electromagnetic contactors inside the dotted lines should be provided by the machine tool builder themselves.

5.2 Signal Distribution

1) CN2M, CN2S (Velocity feedback signal)

14	PA	08		01	0V
15	RA			02	OH2
16	PB			03	OH1
17	RB			04	
18				05	
19				06	
20	SS			13	5V
				07	

2) CNAM, CNAS (Orientation signal)

14	MSA(SC)	08		01	(0H)
15	MSB(*SC)			02	(0H)
16	LSA(PA)			03	(0H)
17	LSB(*PA)			04	(5H)
18	+15V(PB)			05	(5H)
19	0V(*PB)			06	(5H)
20	0G(OG)			13	
				07	

Signal name: using magnetic sensor (for position encoder)

3) CND (Selector signal)

14	CHP1	08		01	SEL1
15	CHP2			02	SEL2
16	CFIN1			03	MCF1
17	CFIN2			04	MCF2
18				05	
19				06	
20	SS			13	
				07	

PCB connector MR-20RMA

PMC connector MR-20LFH

6. INTERFACE

For signals other than those detailed below please refer to II AC Spindle Servo Unit S series.

6.1 Input Signal

6.1.1 Selector demand signals (SEL1, 2)

These signals are inputted in order to select the spindle required. The main spindle and subspindle can be selected by opening (OFF) or closing (ON) the contact respectively.

Please input these signals after the spindle motor has been stopped. The velocity 0 signal is used to confirm that the motor has stopped.

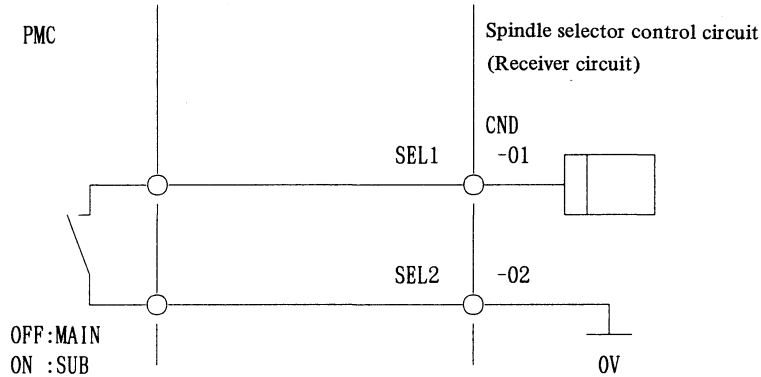

6.1.2 Power line status confirmation signals (MCF1, 2)

Input signal to check selector status of electromagnetic contactor for spindle motor power line selection.

This contact permits the following signal selectors.

OFF: Main spindle

ON : Subspindle

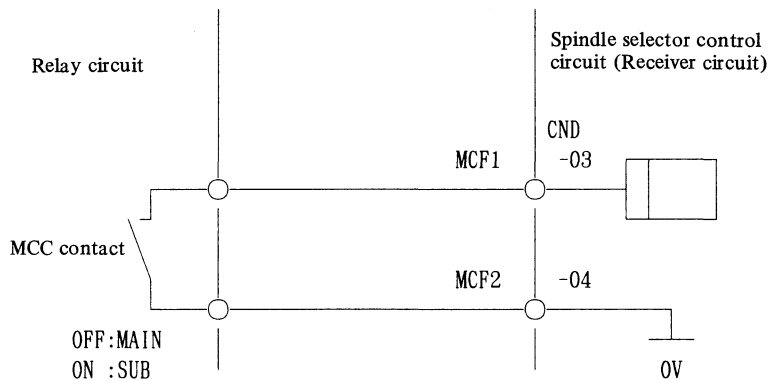

6.2 Output Signals

6.2.1 Power line selector signal (CHP1, 2)

When the selector demand signal (see Section 6.1.1) is received, the motor is stopped, the power supply to the motor is switched off and this signal status changes.

This signal should be used to switch the electromagnetic contactor for power line selection with external relay for power.

Select this signal on and off to make the following selections.

OFF: Main spindle

ON : Subspindle

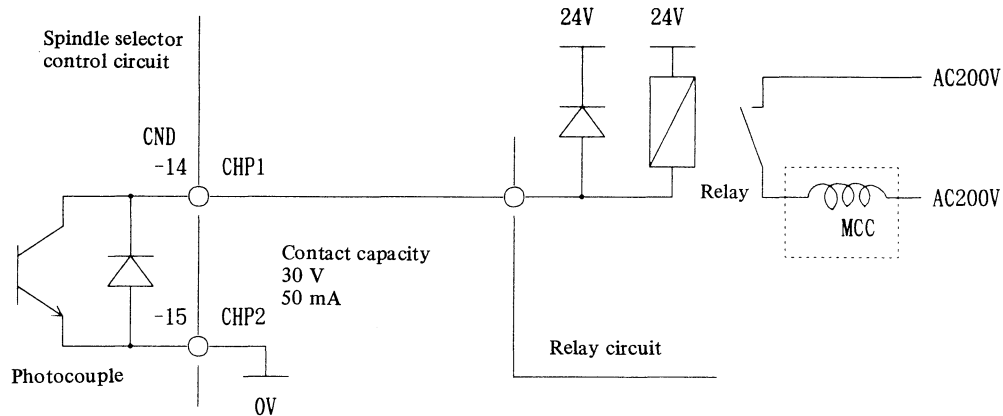

As a photocoupler is used for this output signal, please apply an external relay for 24 VDC, and take care a polarity of CHP1.

6.2.2 Selector completion signal (CFIN1, 2)

This is output signal when the spindle selector demand signal has been inputted and, the power line status confirmation signal input, the selection status checked and confirmed their identity, and the initial setting of the spindle control circuit completed.

The signal indicates that the subsequent operation is now possible.

Select this signal on and off to make the following selection.

OFF: Main spindle

ON : Subspindle

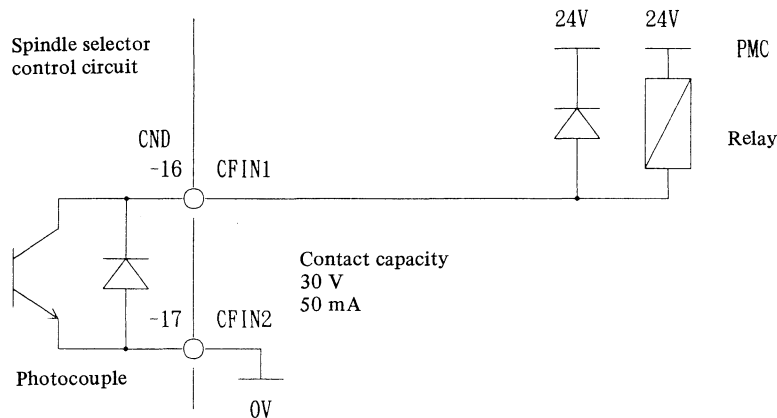

As a photocoupler is used for this output signal, please apply an external relay for 24 VDC, and take care a polarity of CFIN1.

7. SEQUENCE

Control operations should be carried out in the following sequence.

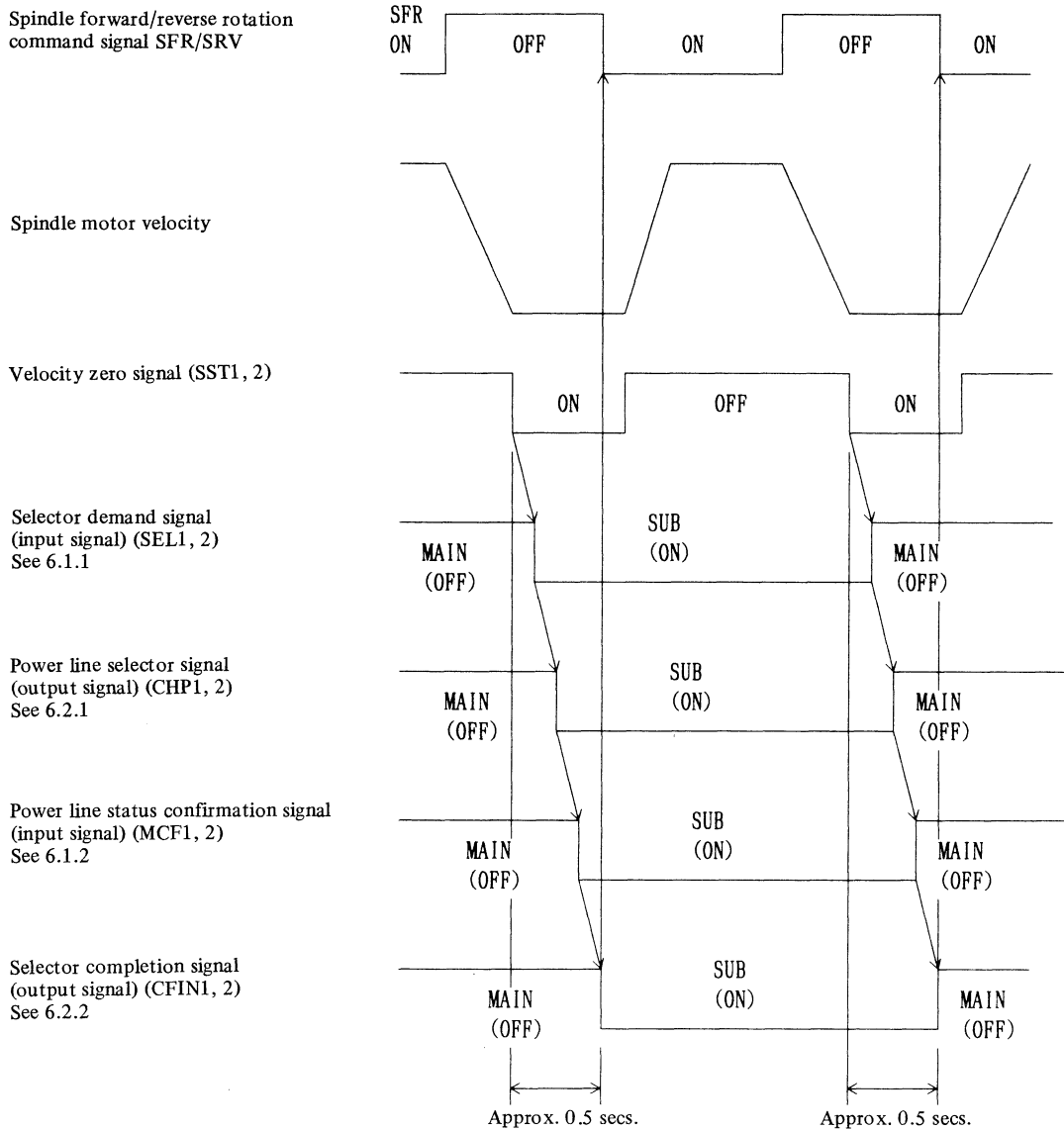

8. IMPORTANT POINTS FOR USING SPINDLE SELECTION CONTROL

- 1) The rating of the electromagnetic contactor for power line selector should be chosen according to the spindle motor.
The electromagnetic contactors given as examples below are made by Fuji Denki.

Motor	Electromagnetic contactor
Models 1S, 1.5S, 2S	SRC3631-5-2
Models 3S, 6S	SRCa3631-2
Models 8S, 12S	SC-2S
Model 15S	SC-3
Model 18S	SC-4
Model 22S	SC-4S

- 2) As a photocoupler is used for this output signal the connections must be made the correct direction. Take careful account of the circuit polarity.
- 3) The maximum voltage for the photocoupler is 30 V, with a maximum current of 50 mA. The voltage and current should be restricted to ensure that they do not exceed these figures.
- 4) Electrical noise from the electromagnetic contactor for power line selector should be suppressed by fitting an S2-A or similar surge absorber with a resistance and condenser.
- 5) Main spindle No. 1 and main spindle No. 2 may have different speed meter voltages and load meter voltages. In that case, the speed meter and load meter should be made selectable using a circuit such as the one shown below.

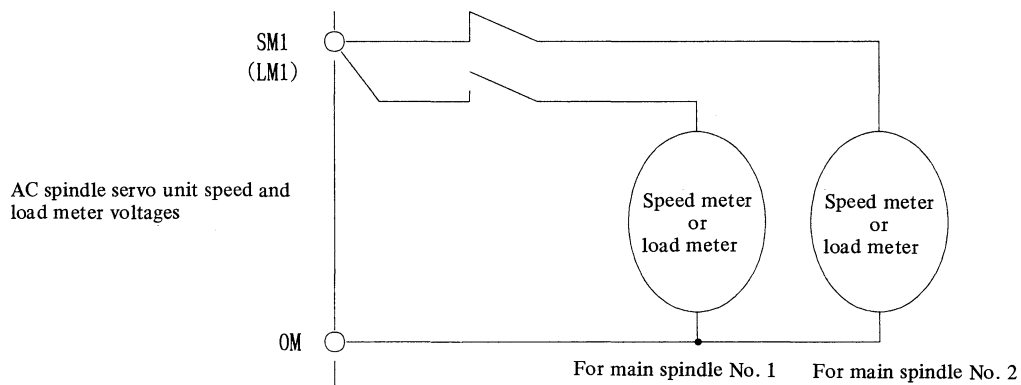

- 6) Setting for parameter F-01 (Machine ready signal MRDY used/not used)
Parameter F-01 should normally be set to "1".
If parameter F-01 is set to "0", MRDY1 and MRDY2 are connected together (pin 7 and pin 8 of connector CN1).
- 7) Even after switching is complete, the motor does not operate for about two seconds (in case of models 6S - 12S) or four seconds (in case of model 15S).
- 8) When the position coder signal is switched, a wire breakage alarm is issued. Reset it when switching is complete.

APPENDIX

APPENDIX 1 CABLE SPECIFICATIONS

The cable specifications are as shown below.
Prepare cables by the MTB.

1) Power line and motive power line for respective motor models

Applications	Symbol	Specifications		FANUC specification (Cable assembly)
		Amp side	Motor side	
Model 1S (Lower than 5 kVA)	K1 K2			
Model 1.5S, 2S, 1S/15000, 2S/15000 (Lower than 7 kVA)	K1 K2			
Model 3S (Lower than 12 kVA)	K1 K2			
Model 6S, 3S/12000, 8P, 12P (Lower than 16 kVA)	K1 K2			
Model 8S, 12S, 6S/12000, 8S/8000, 12S/8000, 15P, 18P, 8VH (Lower than 25 kVA)	K1 K2			

Applications	Symbol	Specifications Amp side Motor side	FANUC specification (Cable assembly)
Model 15S, 15S/8000, 22P, 12VH (Lower than 30 kVA)	K1 K2	<p>Heat resisting vinyl cable (Note)</p> <p>Crimp style terminals 14-8 8 8/0.45 (14mm²) Crimp style terminals R14-5</p>	
Model 18S, 22S, 18S/6000, 22S/6000, 30P, 40P, 50P (Lower than 45 kVA)	K1 K2	<p>Heat resisting vinyl cable (Note)</p> <p>Crimp style terminals 22-8 7/20/0.45 (22mm²) Crimp style terminals 22-8</p>	

Note) Use flame retardant poli-flex cables (MLFC) with a maximum conductor temperature of 105°C.

2) Common cables

The following cables are common for each model.

Purpose	Symbol	General specification	FANUC Spec. DWG. No. (Cable assembly)
Motor cooling fan	K3	<p>Vinyl cabtyre cable JIS C 3312, 3 cores Conductor: 37/0.26 (2 mm²) Sheath: PVC φ10</p> <p>T2-4 φ 10.0 T2-4 Crimp style terminals Crimp style terminals</p>	A06B-6044-K204 7 m
Spindle servo unit AC spindle motor (for symbols)	K4	<p>Spindle servo unit connector (basic) Connector attached to spindle motor</p> <p>CN2 10φ or less Housing 350720-1 Contact 350689-6 4 pairs of shielded cable PVC sheath Conductor with braided shield 0.3 mm² MR-20LFH made by HONDA TSUSHIN</p>	A06B-6044-K200 7 m

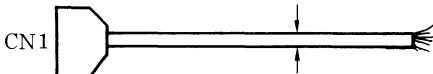
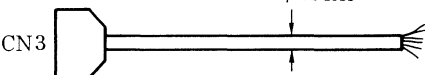
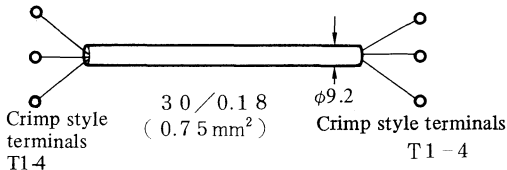
Purpose	Symbol	General specification	FANUC Spec. DWG. No. (Cable assembly)
Spindle servo unit Power cabinet (for signals)	K5	<p>Spindle servo unit connector (basic) Power cabinet</p>  <p>MR-50LFH made by HONDA TSUSHIN Vinyl cable with braided shield 50 cores X 0.2 mm² (7/0.18) made by SANYO DENKO</p>	A02B-6044-K023 7 m
Spindle servo unit Power cabinet (for signals)	K6	<p>Spindle servo unit connector (basic)</p>  <p>MR-20LMH made by HONDA TSUSHIN 4 pairs of shielded cable 0.3 mm²</p>	A06B-6044-K024 7 m
Speedometer Dynamometer Spindle servo unit (for measuring instruments)	K7	<p>Vinyl cabtyre cable JIS C 3312, 3 cores</p>  <p>Crimp style terminals T1-4 3 0 / 0.18 (0.75 mm²) φ9.2 Crimp style terminals T1-4</p>	A06B-6044-K201 7 m

3) Other (cable materials used for some models)

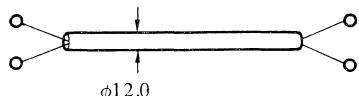
Purpose	Symbol	General specification	FANUC Spec. DWG. No. (Cable assembly)
Resistor unit Spindle servo unit (models 1S - 3S)	K8	<p>Vinyl cabtyre cable JIS C 3312, 2 cores</p>  <p>Crimp style terminals T5.5-4 φ12.0 Crimp style terminals T5.5-4</p> <p>45 / 0.32 (3.5 mm²)</p>	A06B-6052-K200 7 m

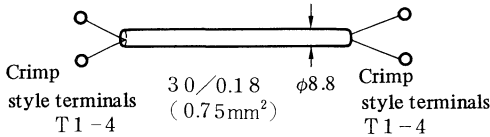

Purpose	Symbol	General specification	FANUC Spec. DWG. No. (Cable assembly)
Resistor unit Power circuit (for thermostat) (models 1S - 3S)	K9	Vinyl cabtyre cable JIS C 3312, 2 cores 	A06B-6052-K203 7 m

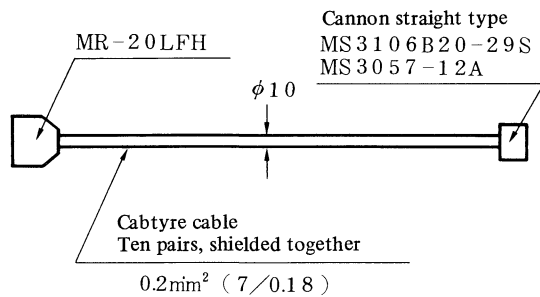
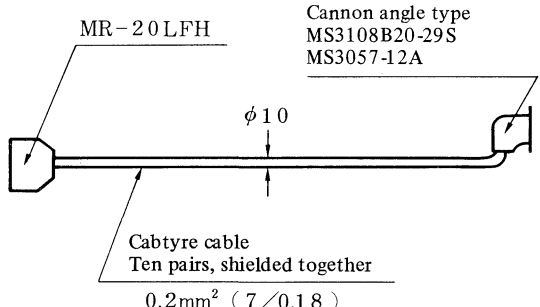
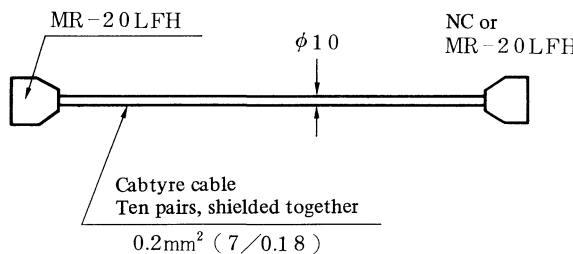
4) Cables for spindle orientation
a) For position coder

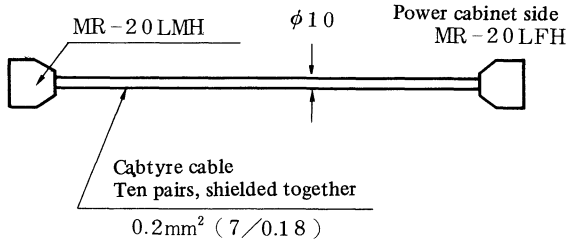
Purpose	Symbol	General specification	FANUC Spec. DWG. No. (Cable assembly)
Spindle servo unit Position coder	K10		A06B-6041-K201 7 m
Spindle servo unit Position coder	K10		A06B-6041-K204 7 m
Spindle servo unit NC or position coder	K11	<p>Spindle servo unit side</p> 	A06B-6041-K202 7 m

Purpose	Symbol	General specification	FANUC Spec. DWG. No. (Cable assembly)
Spindle servo unit Power cabinet	K12	<p>Spindle servo unit side</p>  <p>MR-20LMH $\phi 10$ Power cabinet side MR-20LFH</p> <p>Captyre cable Ten pairs, shielded together 0.2mm² (7/0.18)</p>	A06B-6041-K205 The shielded cable is connected to the pin No. 14 of the connector on the power cabinet side.

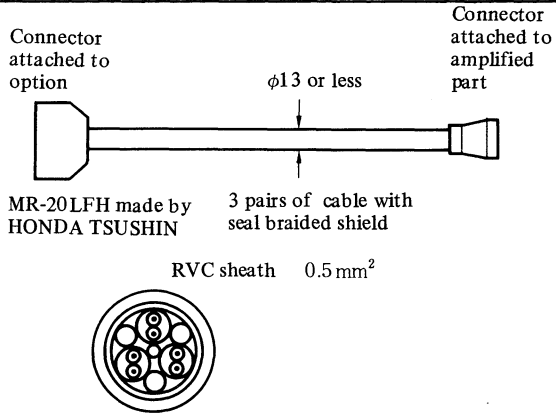
b) For magnetic sensor

Purpose	Symbol	General specification	FANUC Spec. DWG. No. (Cable assembly)
Spindle servo unit Magnetic sensor	K13	<p>Connector attached to option</p>  <p>Connector attached to amplified part</p> <p>$\phi 13$ or less</p> <p>MR-20LFH made by HONDA TSUSHIN 3 pairs of cable with seal braided shield</p> <p>RVC sheath 0.5mm²</p> 	A06B-6041-K203 7 m

<Reference cables>

Details of cable specifications

Name	Conductor		Sheath thickness	Finished OD	Electric characteristics		Designation*
	Diameter	Configuration			Conductor resistance	Allowable current	
Cable A (10 pairs)	$\phi 1.05$ mm	7/0.18	1.4 mm	$\phi 10.0$ mm	110 Ω /km	1.6 A	A66L-0001-0041
Cable B (50 pairs)	$\phi 1.05$ mm	7/0.18	1.5 mm	$\phi 12.5$ mm	106 Ω /km	1.6 A	A66L-0001-0042
Cable C (3 pairs)	$\phi 0.93$ mm	45/0.12	1.0 mm	$\phi 10.8$ mm	38.7 Ω /km	1.6 A	A66L-0001-0108

* Length is designated separately.

APPENDIX 2 TECHNICAL DATA

2.1 How to Obtain Load Inertia Reflected to Motor Shaft

To obtain the load inertia reflected to motor shaft when the spindle holds the maximum tool or maximum work, full the procedure described below.

Spindle speed change gear stage	Inertia reflected to motor shaft
High J_H	_____ kg.cm.s ²
Low J_L	_____ kg.cm.s ²

Select the load inertia reflected to motor shaft so that it is less than 3 times the inertia of the spindle motor employed.

As the load inertia is larger, the acceleration/deceleration time becomes longer.

1) Calculation method of load inertia reflected to motor shaft (Example)

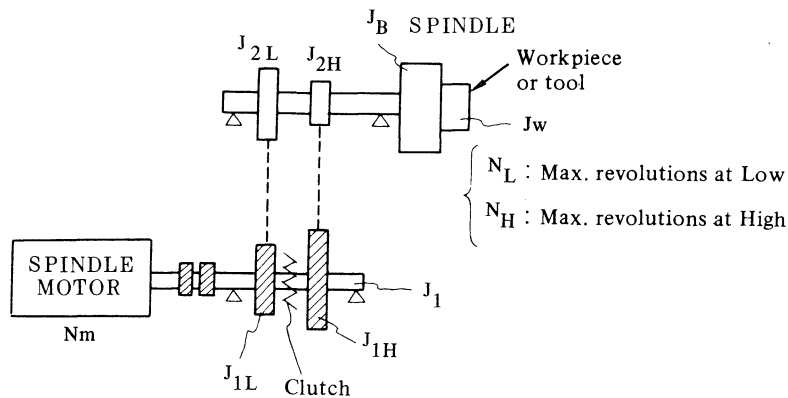

N_m : Maximum speed of motor (rpm)

N_L : Maximum speed when speed change gear stage is low (rpm)

N_H : Maximum speed when speed change gear stage is high (rpm)

R_a : Speed ratio between speed change stages N_H/N_L

G_L : Ratio of motor revolutions to revolutions when speed change gear stage is low N_L/N_M

G_H : Ratio of motor revolutions to revolutions when speed change gear stage is high N_H/N_M

J_1 : Inertia of shaft directly coupled to motor (kg.cm.s²)

J_{1L} : Inertia of gear or pulley when the motor side speed change gear stage is low (kg/cm.s²)

J_{1H} : Inertia of gear or pulley when the motor side speed change gear stage is high (kg/cm.s²)

J_{2L} : Inertia of gear or pulley when the spindle side speed change gear stage is low (kg/cm.s²)

J_{2H} : Inertia of gear or pulley when the spindle side speed change gear stage is high (kg/cm.s²)

J_B : Inertia of spindle (kg.cm.s²)

J_w : Inertia of work (kg.cm.s²)

- ① Calculation formulas when low and high speed change gear stages are switched by clutch
 Inertia reflected to motor shaft when the speed change gear stage is low.
 J_L (kg.cm.s²)

$$J_L = J_1 + J_{1L} + \left(\frac{1}{Ra}\right)^2 \times J_{1H} + G_L^2 \times (J_{2L} + J_{2H} + J_B + J_W) \dots\dots\dots (1-1)$$

Inertia reflected to motor shaft when the speed change gear stage is high. J_H (kg.cm.s²)

$$J_H = J_1 + Ra^2 \times J_{1L} + J_{1H} + G_H^2 \times (J_{2L} + J_{2H} + J_B + J_W) \dots\dots\dots (1-2)$$

- ② Calculation formula when low and high speed change gear stages are switched by gear shift.

$$J_L = J_1 + J_{1L} + J_{1H} + G_L^2 \times (J_{1L} + J_{2L} + J_B + J_W) \dots\dots\dots (1-3)$$

$$J_H = J_1 + J_{1L} + J_{1H} + G_H^2 \times (J_{2L} + J_{2H} + J_B + J_W) \dots\dots\dots (1-4)$$

The calculation formulas of respective inertia are given below.

- ① Inertia of cylindrical body

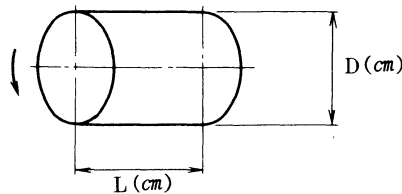

The inertia produced when a cylindrical body rotates around its center shaft is calculated by the following formula. Calculate ball screws, gears, etc. by approximating this formula for cylindrical body.

$$J = \frac{\pi\gamma}{32 \times 980} D^4 L \text{ (kg.cm.s}^2\text{)} \dots\dots\dots (1-5)$$

This can be approximated in case of steel ($\gamma = 7.8 \times 10^{-3}$ kg/cm³) as follows.

$$J = 0.78 \times 10^{-6} D^4 L \text{ (kg.cm.s}^2\text{)} \dots\dots\dots (1-6)$$

- where, J: Inertia (kg.cm.s²)
 γ : Weight per unit volume (kg/cm³)
 D: Diameter of cylindrical body (cm)
 L: Length of cylindrical body (cm)

② Inertia of cylindrical body having a deviated rotation center

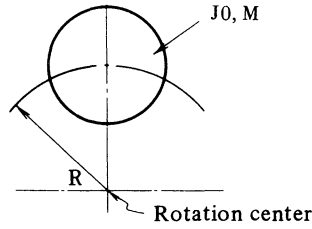

$$J = J_0 + \frac{M}{980} R^2 \text{ (kg.cm.s}^2\text{)} \dots\dots\dots (1-7)$$

where, J_0 : Inertia around the center of cylindrical body (kg.cm.s²)
 M : Weight of cylindrical body (kg)
 R : Rotation radius (cm)

The above formula applies to calculations of the inertia of large diameter gears when lightening holes were made for reducing their weight.

③ Inertia of tapered cylindrical body

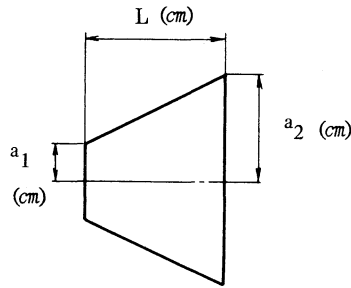

$$J = \frac{\pi\gamma}{10 \times 980} \times \frac{(a_2^5 - a_1^5)}{(a_2 - a_1)} \times L \text{ (kg.cm.s}^2\text{)} \dots\dots\dots (1-8)$$

2.2 Load Torque

The friction torque of bearings and viscosity torque of lubrication oil inside the spindle act as the load torque.

$$T_L = T_c + T_v \text{ (kg.cm)}$$

where, T_c : Friction torque
 T_v : Viscosity torque

Be careful since the viscosity torque of lubrication oil largely affects the machine when the spindle rotates at high speed.

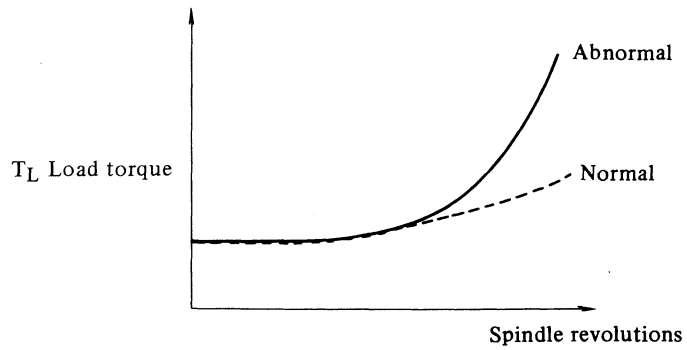

2.3 Spindle Speed Change Gear Stage

The spindle gear speed change stages are determined according to the specified output of the spindle.

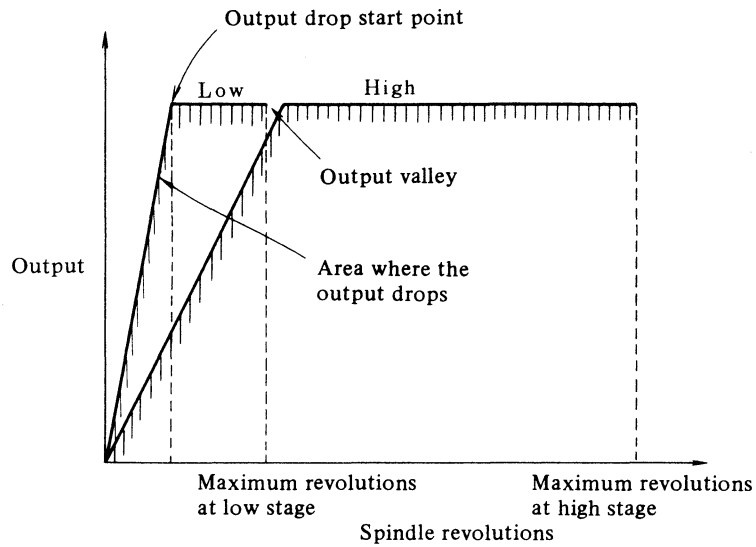

To eliminate the output valley, the ratio of high to low stages of spindle is generally set as follows.

$$\frac{\text{Max. revolutions at low stage}}{\text{Max. revolutions at high stage}} = \frac{\text{Basic speed of motor}}{\text{Max. speed of motor}} = \frac{1}{3} \text{ to } \frac{1}{4}$$

Since the revolutions lower than the output drop start point of low gears cause the cutting power of machine to decrease, the revolutions must be specified clearly.

2.4 How to Find the Acceleration Time

Find the spindle acceleration time in the following manner.

- 1) Calculate the load inertia for the motor shaft.
- 2) Find the value required for calculation based on the spindle motor characteristic table.
- 3) Find the acceleration time according to the calculation expression.

1) Motor shaft conversion load inertia (J_L)

According to para. 1 above, find the load inertia. When GD^2 ($kg.m^2$) is found, convert the unit system according to the following equation.

$$J_L \text{ (kg.m.s}^2\text{)} = \frac{GD^2 \text{ (kg.m}^2\text{)}}{4g \text{ (m/s}^2\text{)}} \dots\dots\dots (4-1)$$

Therefore, $1 \text{ kg.m}^2 = 0.0255 \text{ kg.m.s}^2$

2) Spindle motor characteristic table

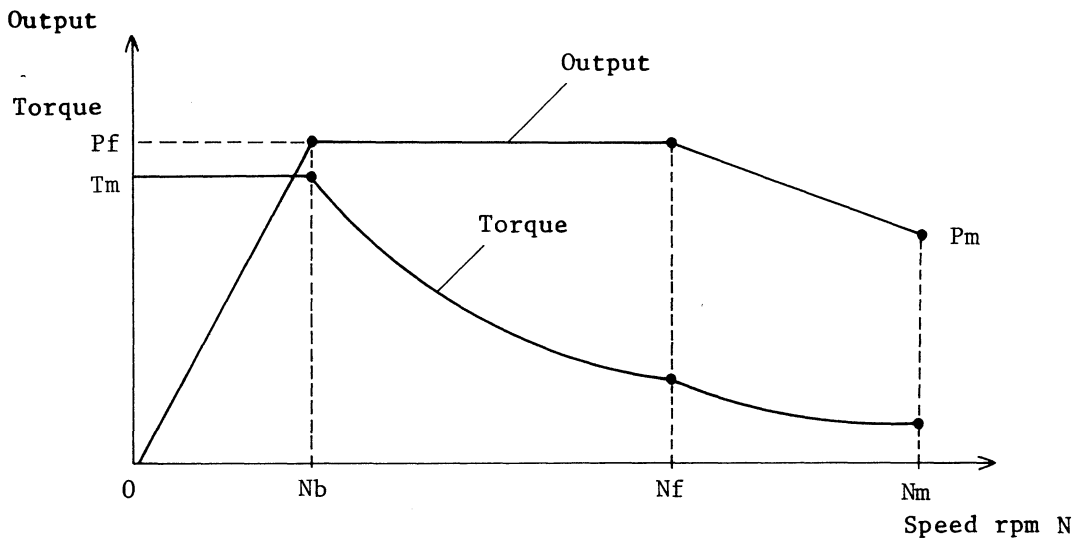

The following relation exists among output P, torque T and speed rpm N.

$$P \text{ (kW)} = 1.0269 \times N \times T/1000 \dots\dots\dots (4-2)$$

Characteristics of each model at 30-minute rating output

Model	J_m kg.m.s ²	T_m kg.m	N_b rpm	N_f rpm	N_m rpm	P_f W	P_m W
1S	0.0003	0.71	3000	-	8000	-	2200
1.5S	0.0004	2.40	1500	6000	8000	3700	2500
2S	0.0008	2.40	1500	6000	8000	3700	2500
3S	0.0015	3.57	1500	4500	6000	5500	3700
6S	0.0022	4.87	1500	4500	6000	7500	5500
8S	0.0028	7.14	1500	-	6000	-	11000
12S	0.0093	9.74	1500	4500	6000	15000	11000
15S	0.0093	12.01	1500	4500	6000	18500	15000
18S	0.0129	14.28	1500	-	4500	-	22000
22S	0.0129	16.88	1500	-	4500	-	26000

3) Calculation of acceleration time - 1

Acceleration curve

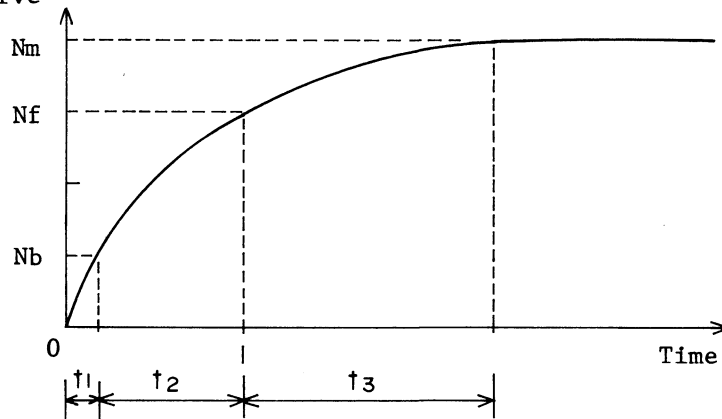

Acceleration time
 - Speed 0 to Nb (rpm)

$$t_1 = \frac{J_L + J_m}{T_m} \times \frac{2\pi N_b}{60} \text{ (sec)} \dots\dots\dots (4-3)$$

- Speed Nb to Nf

$$t_2 = \frac{J_L + J_m}{T_m} \times \frac{2\pi}{60} \times \frac{(N_f^2 - N_b^2)}{2N_b} \text{ (sec)} \dots\dots\dots (4-4)$$

- Speed Nf to Nm

$$t_3 = 1.0269 \times (J_L + J_m) \times \frac{2\pi}{60} \times \frac{(N_m - N_f)^2}{(P_f - P_m)^2} \times \left\{ - (P_f - P_m) + \frac{(P_f N_m - P_m N_f)}{(N_m - N_f)} \times L_n \left| \frac{P_f}{P_m} \right| \right\} \dots\dots\dots (4-5)$$

where, L_n : Natural logarithm

Acceleration time t_a

$$t_a = t_1 + t_2 + t_3 \text{ (sec)} \dots\dots\dots (4-6)$$

By controlling the deceleration time to nearly the same time as the acceleration time, the elongation of the tap during tapping processing can be reduced.

4) Calculation of acceleration time - 2

The acceleration time at the rated torque is shown below. The mechanical load torque is ignored.

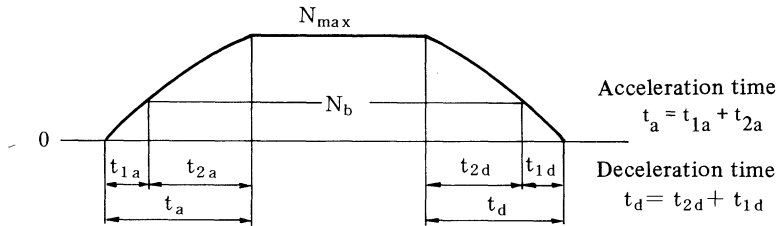

Acceleration time
 - Speed 0 to Nb

$$t_1 \text{ (sec)} = \int_0^{N_b} \frac{J_L + J_m}{T_m} \times \frac{2\pi}{60} dN$$

$$= \frac{J_L + J_m}{T_m} \times \frac{2\pi N_b}{60} \dots\dots\dots (4-7)$$

- Speed Nb to Nmax

$$t_2 \text{ (sec)} = \int_{Nb}^{N_{max}} \frac{J_L + J_m}{\frac{Nb}{N} \times T_m} \times \frac{2\pi}{60} dN$$

$$= \frac{J_L + J_m}{T_m} \times \frac{2\pi}{60} \times \frac{1}{2Nb} (N_{max}^2 - Nb^2) \dots\dots\dots (4-8)$$

- Speed 0 to Nmax

$$t_a \text{ (sec)} = t_1 + t_2 = \frac{J_L + J_m}{T_m} \times \frac{2\pi}{60}$$

$$\left\{ Nb + \frac{N_{max}^2 - Nb^2}{2Nb} \right\} \dots\dots\dots (4-9)$$

Generally Nb/Nmax = 1/3. Substituting this formula becomes:

$$t_a \text{ (sec)} = \frac{J_L + J_m}{T_m} \times \frac{2\pi}{60} \times \frac{5}{3} \times N_{max} \dots\dots\dots (4-10)$$

where, J_L : Load inertia converted into motor shaft (kg.m.s²)
 J_m : Rotor inertia of DC motor (kg.m.s²)
 T_m : Maximum torque (kg.m)

2.5 Calculation of Time Constant for Rigid Tapping

Calculation flowchart

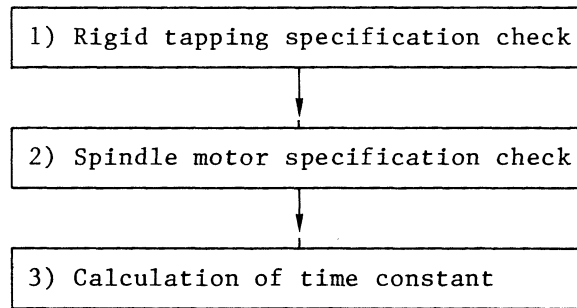

1) Rigid tapping specification check

- ① Define the range of the machine's screw cutting capability:

M0 - M00

(Example) M3 - M27

- ② Motor spindle conversion load inertia of main spindle:
 $JL[\text{kg}\cdot\text{cm}\cdot\text{s}^2]=$
- ③ Rotor inertia of spindle motor:
 $Jm[\text{kg}\cdot\text{cm}\cdot\text{s}^2]=$
- ④ Velocity ratio of main spindle to motor spindle (1/gear ratio):
Check the number of teeth on each spindle's gears.
- ⑤ Gearing ratio of main spindle to position coder:
Check 1:1, 1:2 and so on.

<Reference>

Waveform

There are two types of the velocity waveform as shown in Fig. 1 and Fig. 2, but the revolutions of the main spindle should be reduced for rigid tap machining in order to produce the waveform in Fig. 2 where there is, for example, gear coupling backlash between the main spindle and the motor and where the screw requires a high degree of machining accuracy.

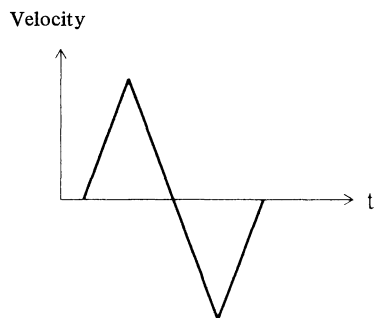

Fig. 1

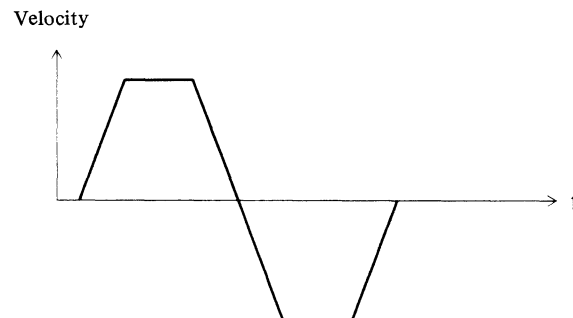

Fig. 2

Reason: At the pinnacle of the triangular waveform in Fig. 1 the main spindle velocity following deteriorates and screw machining accuracy is lost.

2) Spindle motor specification check

The following three points should be checked in advance.

- ① The model name and output specifications of the AC spindle which you are going to use.
- ② The appropriate number of revolutions for the AC spindle motor during the rigid tapping operation.

$$\text{Number of spindle motor revolutions} = \frac{1}{(\text{deceleration ratio } \alpha)} \times \text{Number of revolutions of spindle}$$

- ③ The calculation, as described in the specification manual, of the 30 minute rated torque at maximum revolution velocity using the AC spindle motor's velocity curve.

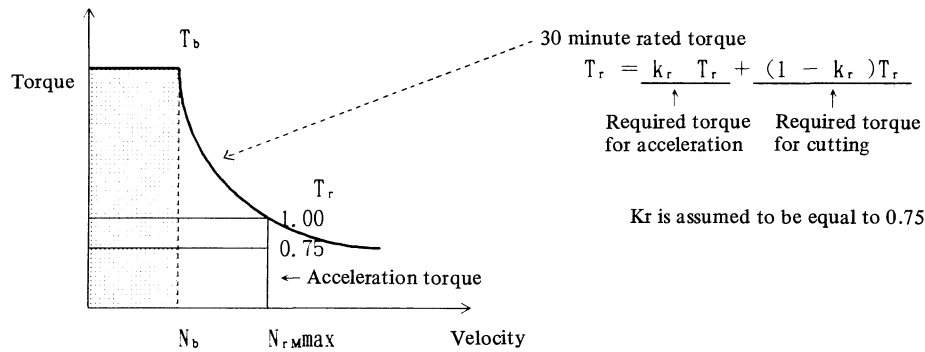

The following time constant calculations were made on the assumption that the 30 minute rated torque is equal to the sum of the required torque for acceleration up to NrMmax number of revolutions and the required torque for cutting.

<Note>

Machines with the rigid tapping function must have a small motor spindle conversion load inertia in order to minimize the acceleration time.

3) Calculation of time constant

a) For the FANUC Series 0-MB (0417 Series)

When the number of revolutions for machining NrMmax has been determined for an AC spindle motor used for the rigid tapping operation, read the 30 minute rated output torque Tr [kg·m] from the motor's torque velocity curve.

When only the 30 minute rated output Pr [kW] is known, use the following formula to calculate the torque Tr [kg·m].

$$Tr = \frac{Pr \times 1000}{1.0269 \times NrMmax} \text{ [kg}\cdot\text{m]} \dots\dots\dots (1)$$

The acceleration time t_r from 0 to N_{rMmax} during linear acceleration and deceleration is calculated using the following formula.

$$t_r = \frac{JL + JM}{kr \times Tr} \times \frac{2\pi N_{rMmax}}{60} \times \frac{1}{100} \dots\dots (2)$$

Where

JL: motor spindle conversion load inertia [kg·cm·s²]

JM: motor rotor inertia [kg·cm·s²]

kr: acceleration torque safety coefficient for linear acceleration and deceleration (kr = 0.75)

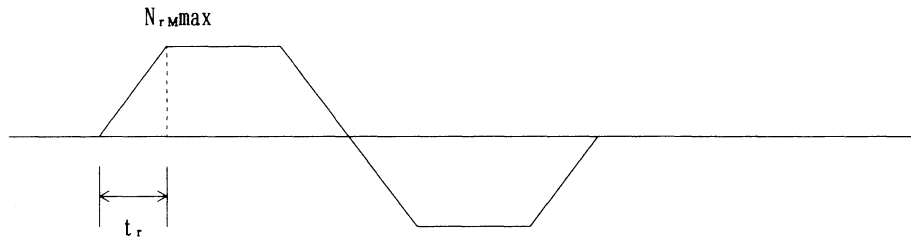

Formulas (1) and (2) above can be used to calculate the time constant t_r up to the N_{rMmax} number of revolutions.

When a time constant setting is chosen for the FANUC Series 0-MB [0417 Series] (by setting bit 6 of Parameter No. 37 to 1), the time constant changes at a constant rate, decreasing in proportion to the number of main spindle revolutions.

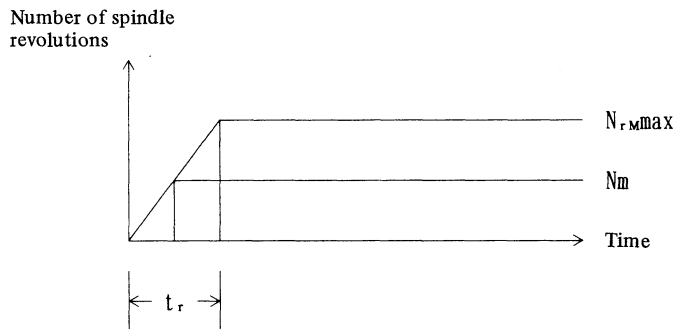

(Example 1)

For the FANUC Series 0-MB (0417 Series)

The time constant t_r for rigid tapping using the AC Spindle Motor model 3S (JM = 0.15 kg·cm·s²) at 3000 rpm can be calculated as follows.

Where

JL (motor spindle conversion load inertia) = 0.1 kg·cm·s²

$$Tr = \frac{5.5 \times 1000}{1.0269 \times 3000} = 1.78 \text{ [kg·m]}$$

$$t_r = \frac{0.15 + 0.1}{kr \times Tr} \times \frac{2\pi \times 3000}{60} \times \frac{1}{100}$$

$$= 0.588 \text{ [sec]}$$

The time constant should be set the value in excess of 588 ms.

b) For the FANUC Series 0-MB (0415, 0416 Series)

For these series the time constant refers to the time required for the Z axis to reach the limit velocity of the cutting feed [Example: 4 m/min]. This time constant can be found as follows. Find the Z axis cutting feed velocity f_m from the number of main spindle revolutions N_m (rpm) and the screw pitch p .

$$f_m = p \times N_m \text{ (mm/min)} \dots\dots\dots (1)$$

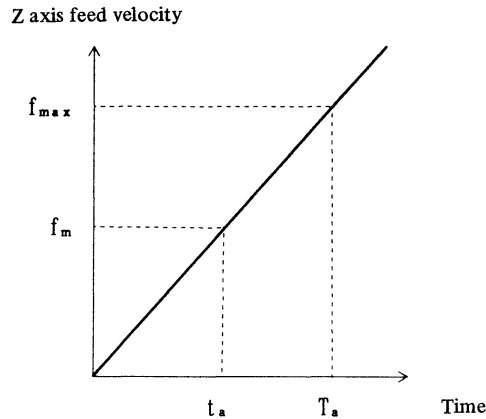

The Z axis cutting feed limit velocity f_{max} and the time t_a required to reach that velocity stand for the following formulas.

$$T_a = \frac{f_{max}}{f_m} \times t_a \dots\dots\dots (2)$$

Where the number of main spindle revolutions is NM , the number of motor revolutions is N_m and the deceleration ratio is α , the following relationship holds

$$N_m = NM/\alpha \dots\dots\dots (3)$$

Linear acceleration time N_m can be calculated using the following formula.

$$t_a = \frac{J_M + J_L}{k_r \times Tr} \times \frac{2\pi N_m}{60} \times \frac{1}{100} \text{ (sec)} \dots\dots\dots (4)$$

The time T_a taken to attain the Z axis cutting feed limit velocity can now be calculated by using the above formulas (2), (3) and (4) as follows.

$$T_a = \frac{f_{max}}{f_m} \times t_a$$

$$= \frac{f_{max}}{f_m} \times \frac{J_M + J_L}{k_r \times Tr} \times \frac{2\pi NM/\alpha}{60} \times \frac{1}{100} \text{ (sec)} \dots\dots\dots (5)$$

(Differences between these series and the 0417 Series)

- ① The time constant setting is made f_{max}/f_m times as large.
- ② The time constant does not change at a constant rate. It is definite whatever revolution velocity is reached.

(Example 2)

For the FANUC Series 0-MB (0415, 0416 Series)

The time constant t_r for M3 rigid tapping using the AC spindle motor model 3S ($J_M = 0.15 \text{ kg}\cdot\text{cm}\cdot\text{s}^2$) at a main spindle velocity of 3000 rpm can be calculated as follows.

The maximum cutting feed velocity is 4 m/min.

Where

J_L (motor spindle conversion load inertia) = $0.1 \text{ kg}\cdot\text{cm}\cdot\text{s}^2$

The M3 screw pitch is 0.5 mm, so the cutting feed velocity is

$$f_m = 0.5 \times 3000 = 1500 \text{ mm/min}$$

The acceleration time up to a main spindle velocity of 3000 rpm (where the deceleration ratio $\alpha = 1$ and the number of motor revolutions = 3000 rpm) can be calculated as follows.

$$T_r = \frac{5.5 \times 1000}{1.0269 \times 3000} = 1.78 \text{ [kg}\cdot\text{m]}$$

$$\begin{aligned} t_r &= \frac{0.15 + 0.1}{k_r \times T_r} \times \frac{2\pi \times 3000}{60} \times \frac{1}{100} \\ &= 0.588 \text{ [sec]} \end{aligned}$$

The time constant for the Z axis cutting feed is as follows.

$$T_a = \frac{4000}{1500} \times 0.588 = 1.57 \text{ sec}$$

In this case the time constant appropriate for the number of main spindle revolutions is as follows.

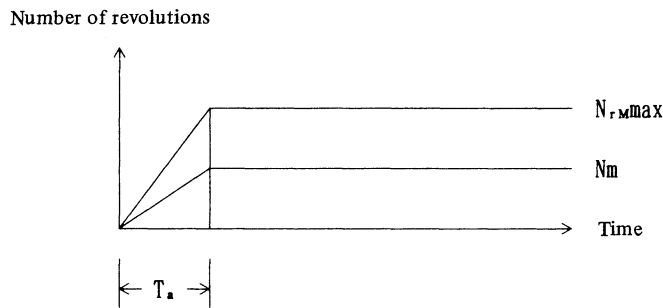

c) For the FANUC Series 10M/11M/12M/15M

In order to reduce machining time the attainment of the appropriate number of main spindle revolutions in three stages with their own time constant has been made possible.

The number of motor revolutions N_m is found from the deceleration ratio α and the number of main spindle revolutions N_M . The 30 minute rated torque at each number of revolutions is found from the motor torque revolution characteristics and the time constant are calculated.

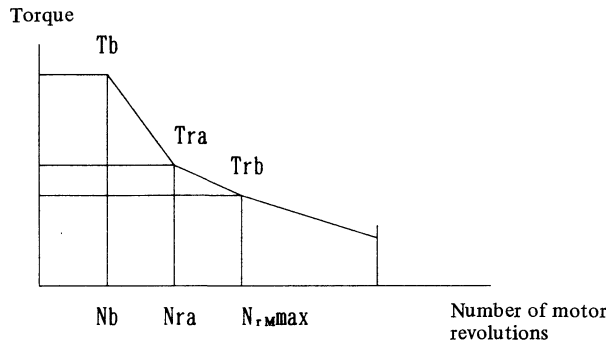

$$TC1 = \frac{JL + JM}{kr \times Tb} \times \frac{2\pi Nb}{60} \times \frac{1}{100} \dots\dots\dots (1)$$

$$TC2 = \frac{JL + JM}{kr \times Tra} \times \frac{2\pi Nra}{60} \times \frac{1}{100} \dots\dots\dots (2)$$

$$TC3 = \frac{JL + JM}{kr \times Trb} \times \frac{2\pi N rMmax}{60} \times \frac{1}{100} \dots\dots\dots (3)$$

Number of main spindle revolutions in three stages with their respective time constants

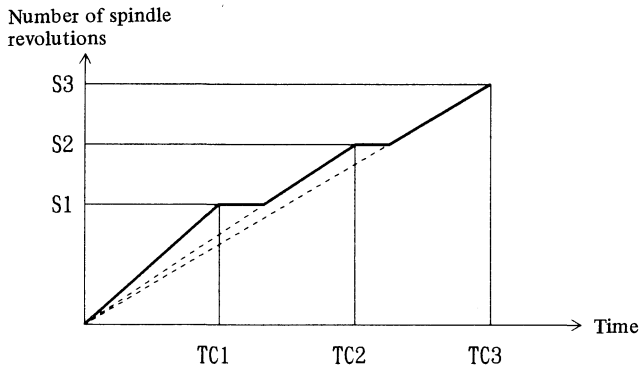

Fig. 4-(2)

(Example 3)

Using the AC spindle motor model 3S where $S1 = 1500$ rpm, $S2 = 2500$ rpm and $S3 = 3500$ rpm, $TC1$, $TC2$ and $TC3$ are as follows.

$$TC1 = \frac{0.15 + 0.1}{0.75 \times 3.57} \times \frac{2\pi \times 1500}{60} \times \frac{1}{100} = 0.146 \text{ sec} \quad 146 \text{ ms}$$

$$TC2 = \frac{0.15 + 0.1}{0.75 \times 2.14} \times \frac{2\pi \times 2500}{60} \times \frac{1}{100} = 0.408 \text{ sec} \quad 408 \text{ ms}$$

$$TC3 = \frac{0.15 + 0.1}{0.75 \times 1.53} \times \frac{2\pi \times 3500}{60} \times \frac{1}{100} = 0.799 \text{ sec} \quad 799 \text{ ms}$$

2.6 Cutting Amount of Machine

The spindle motor output (HP or KW) of machine tools is specified to indicate their cutting amount, in general.

Regarding the lathing, milling, and drilling, the relation between the rate of metal removal and output power will be described by quoting it from the following reference.

Reference: MACHINING DATA HANDBOOK AIR FORCE MATERIAL LABORATORY

- a) Lathe turning
- b) Machining center, milling using milling machine
- c) Machining center, drilling using drilling machine

a) Turning

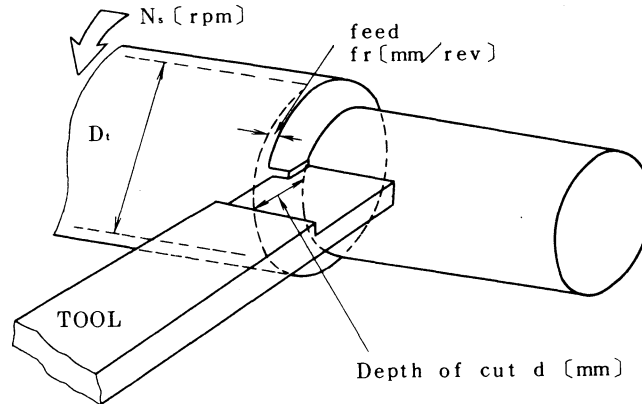

Cutting conditions:

- | | |
|------------------------|----------------|
| 1) Spindle revolutions | N_s (rpm) |
| 2) Workpiece diameter | D_t (mm) |
| 3) Feed | f_r (mm/rev) |
| 4) Depth of cut | d (mm) |

Cutting formulas:

- | | |
|--------------------------|---|
| 1) Cutting speed | $V_c = \pi \times D_t \times N_s$ (mm/min) |
| 2) Feed rate | $f_m = f_r \times N_s$ (mm/min) |
| 3) Rate of metal removal | $Q = d \times f_r \times V_c / 1000$ (cm ³ /min) |
| | $= d \times f_r \times \pi \times D_t \times N_s / 1000$ (cc/min) |

$$Q = \pi \times D_t \times d \times f_m / 1000 \text{ (cc/min)}$$

4) Power required at spindle

$$P_S = Q / MR_t \text{ (kW)}$$

where, MR_t : Rate of metal removal per kW
(cc/min/kW)

5) Power required at spindle motor

$$P_M = \frac{1}{\eta} \times Q / MR_t$$

where, η : Drive efficiency of spindle
(%)

b) Milling

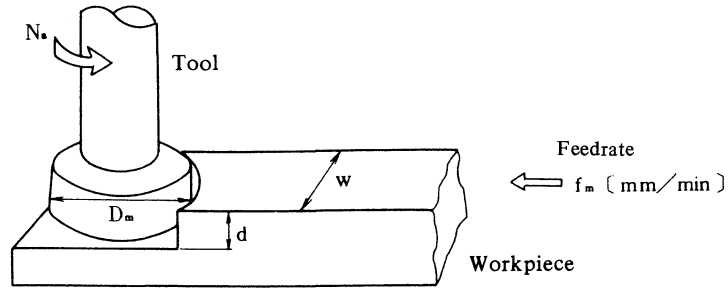

Cutting conditions:

- | | |
|-------------------------------|------------------|
| 1) Spindle revolutions | N_s (rpm) |
| 2) Diameter of milling cutter | D_m (mm) |
| 3) Width of cut | w (mm) |
| 4) Depth of cut | d (mm) |
| 5) Number of teeth in cutter | n (pieces) |
| 6) Feed | f_t (mm/tooth) |

Cutting formulas:

- | | |
|--------------------------|---|
| 1) Cutting speed | $V_c = \pi \times D_m \times N_s$ (mm/min) |
| 2) Feed rate | $f_m = f_t \times n \times N_s$ (mm/min) |
| 3) Rate of metal removal | $Q = w \times d \times f_t \times n \times N_s / 1000$ (cm ³ /min) |

$$Q = w \times d \times f_m / 1000 \text{ (cc/min)}$$

- | | |
|------------------------------------|---|
| 4) Power required at spindle | $PS = Q / MR_m$ (kW) |
| | where, MR_m : Rate of metal removal per kW
(cc/min/kW) |
| 5) Power required at spindle motor | $PM = \frac{1}{\eta} \times Q / MR_m$ (kW) |
| | where, η : Drive efficiency of spindle
(%) |

c) Drilling

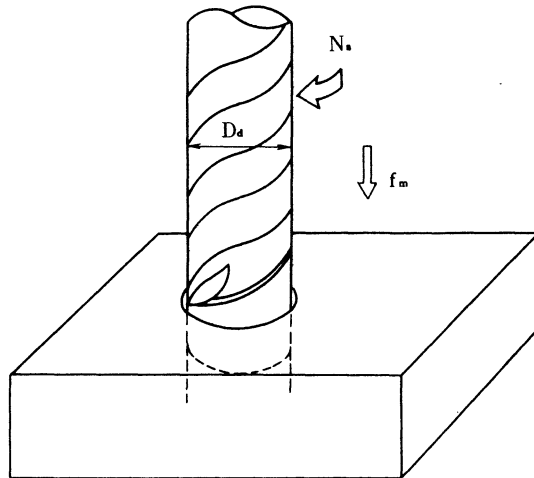

Cutting conditions:

- 1) Spindle revolutions
- 2) Drill diameter
- 3) Feed

- N_s (rpm)
 D_d (mm)
 f_t (mm/rev)

Cutting formulas:

- 1) Cutting speed
- 2) Feed rate
- 3) Rate of metal removal

- $V_c = \pi \times D_d \times N_s$ (mm/min)
 $f_m = f_r \times N_s$ (mm/min)
 $Q = \frac{\pi}{4} \times D_d^2 \times f_r \times N_s / 1000$ (cm³/min)

$$Q = \frac{\pi}{4} \times D_d^2 \times f_m / 1000 \text{ (cc/min)}$$

- 4) Power required at spindle

$PS = Q / MR_d$ (kW)
 where, MR_d : Rate of metal removal per kW
 (cc/min/kW)

- 5) Power required at spindle motor

$PM = \frac{1}{\eta} \times Q / MR_d$ (kW)
 where, η : Drive efficiency of spindle
 (%)

Rate of metal removal per kW (cc/min/kW) (average values)
 (when the drive efficiency of spindle is 80%)

MATERIAL	HARDNESS (*1) Brinell hardness	MR: Rate of metal removal per kW (cc/min/kW)					
		TURNING MRt HSS AND CARBIDE TOOLS feed 0.127 - 0.381 mm/rev		MILLING MRm CARBIDE TOOLS feed 0.127 - 0.305 mm/tooth		DRILLING MRd HSS DRILLS feed 0.05 - 0.203 mm/rev	
		SHARP TOOL	DULL TOOL	SHARP TOOL	DULL TOOL	SHARP TOOL	DULL TOOL
STEEL-WROUGHT AND CAST Plain Carbon Alloy Steels Tool Steels	85-200(*4)	20	15.7	20	15.7	21.9	16.8
	35-40Rc(*2)	15.7	12.9	14.6	11.5	15.7	12.9
	40-50Rc	14.6	11.5	12.2	10	12.9	10.4
	50-55Rc	10.9	8.7	10.4	8.4	10.4	8.4
	55-58Rc	6.4	5.2	8.4	6.8	8.4	6.8 (*5)
CAST IRONS Gray, Ductile and Malleable	110-190	31.3	24.4	36.6	27.4	21.9	18.3
	190-320	15.7	12.9	20	15.7	13.7	10.9
STAINLESS STEELS Ferritic, Austenitic and Martensitic	135-275	16.8	13.7	15.7	12.9	20	15.7
	30-45Rc	15.7	12.9	14.6	11.5	18.3	14.6
PRECIPITATION HARDENINGS STAINLESS STEELS	150-450	15.7	12.9	14.6	11.5	18.3	14.6
TITANIUM	250-375	18.3	14.6	20	15.7	20	15.7
HIGH TEMPERATURE ALLOYS Nickel and Cobalt Base	200-360	8.7	7.0	10.9	8.7	10.9	8.7
Iron Base	180-320	13.7	10.9	13.7	10.9	18.3	14.6
REFRACTORY ALLOYS ... Tungsten	321	7.8	6.2	7.5	6.1	8.4	6.6 (*5)
Molybdenum	229	10.9	8.7	13.7	10.9	13.7	10.9
Columbium	217	12.9	10.4	14.6	11.5	15.7	12.9
Tantalum	210	7.8	6.2	10.9	8.7	10.4	8.4
NICKEL ALLOYS	80-360	10.9	8.7	11.5	9.1	12.2	10
ALUMINUM ALLOYS	30-150 500 kg	87.8	73.2	68.6	54.9	137.2	109.8

MATERIAL	HARDNESS (*1) Brinell hardness	MR: Rate of metal removal per kW (cc/min/kW)					
		TURNING MRt HSS AND CARBIDE TOOLS feed 0.127 - 0.381 mm/rev		MILLING MRm CARBIDE TOOLS feed 0.127 - 0.305 mm/tooth		DRILLING MRd HSS DRILLS feed 0.05 - 0.203 mm/rev	
		SHARP TOOL	DULL TOOL	SHARP TOOL	DULL TOOL	SHARP TOOL	DULL TOOL
MAGNESIUM ALLOYS	40-90 500 kg	137.2	109.8	137.2	109.8	137.2	109.8
COPPER	80Rb (*3)	21.9	18.3	21.9	18.3	24.4	20
COPPER ALLOYS	10-80Rb	34.3	27.4	34.3	27.4	45.7	36.6
	80-100Rb	21.9	18.3	21.9	18.3	27.4	21.9

Note 1) Brinell hardness, Standard testing method, Steel ball diameter 10 mm,
Load: 3000 kg, Maximum value about 450

Note 2) Rc: Rockwell hardness, C scale, Measurement of hardness of comparatively
hard metals

Note 3) Rb: Rockwell hardness, B scale, Measurement of hardness of soft metals

Note 4) Corresponds to hardness of general steel S45C

Note 5) Carbide

Efficiency of spindle drive system

The efficiency of spindle system can be obtained from the following diagram according to the V belt, number of gear stages, and number of bearings.

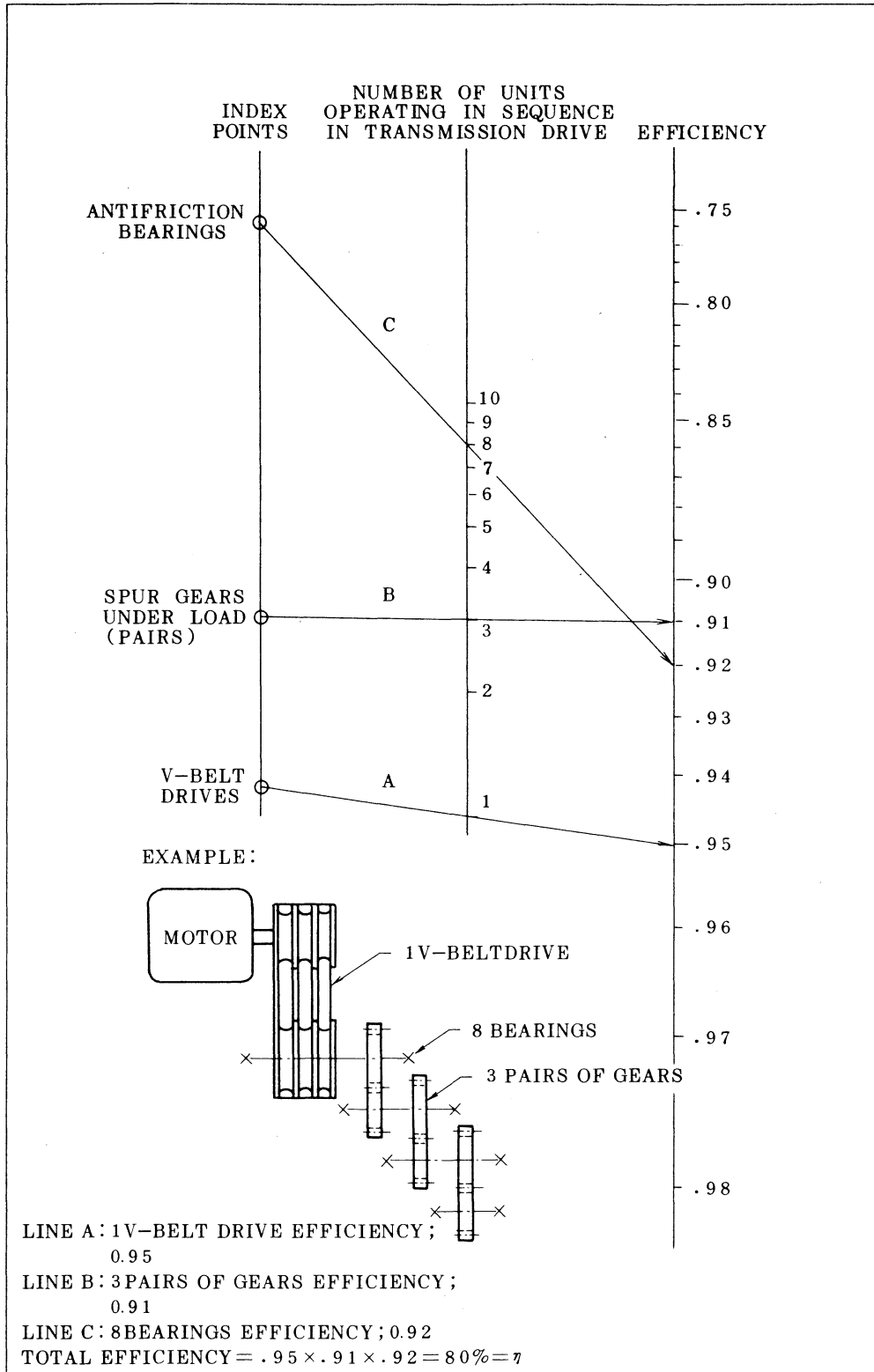

Data on rate of metal removal

The rate of metal removal per minute when steel S45C is cut using a new tool on a lathe or machining center is obtained within the shadowed range in the following figure approximately; provided that no-load torque such as friction torque, etc. are negligible.

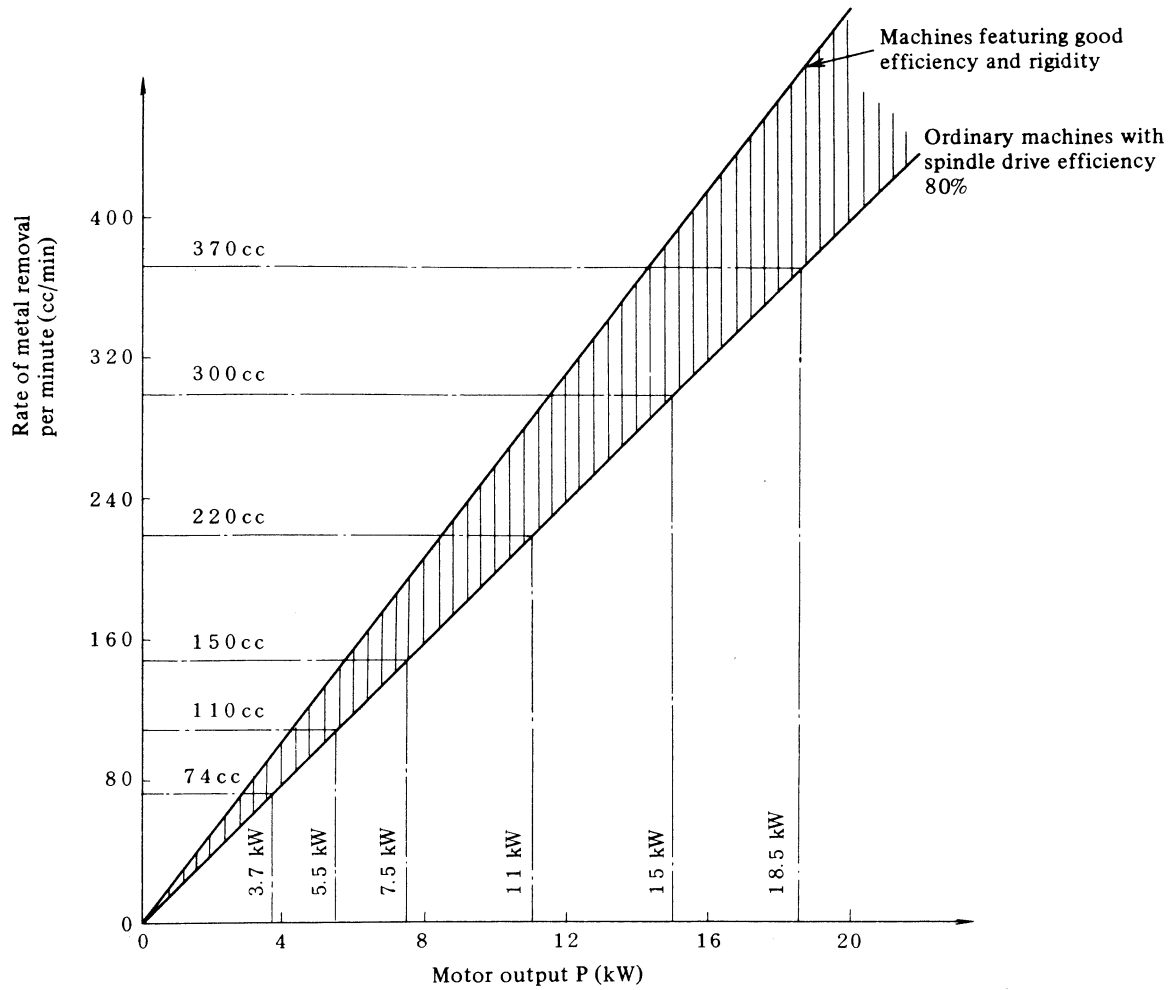

2.7 Constant Surface Speed Control

- . Purpose of constant surface speed control in lathe
 - 1) Good finish surface
 - 2) Reduction of lathing time
 - 3) Constant rate of metal removal
 - 4) Prolonged lives of tools by setting the surface speed to a suitable value
- . Constant surface speed control operation

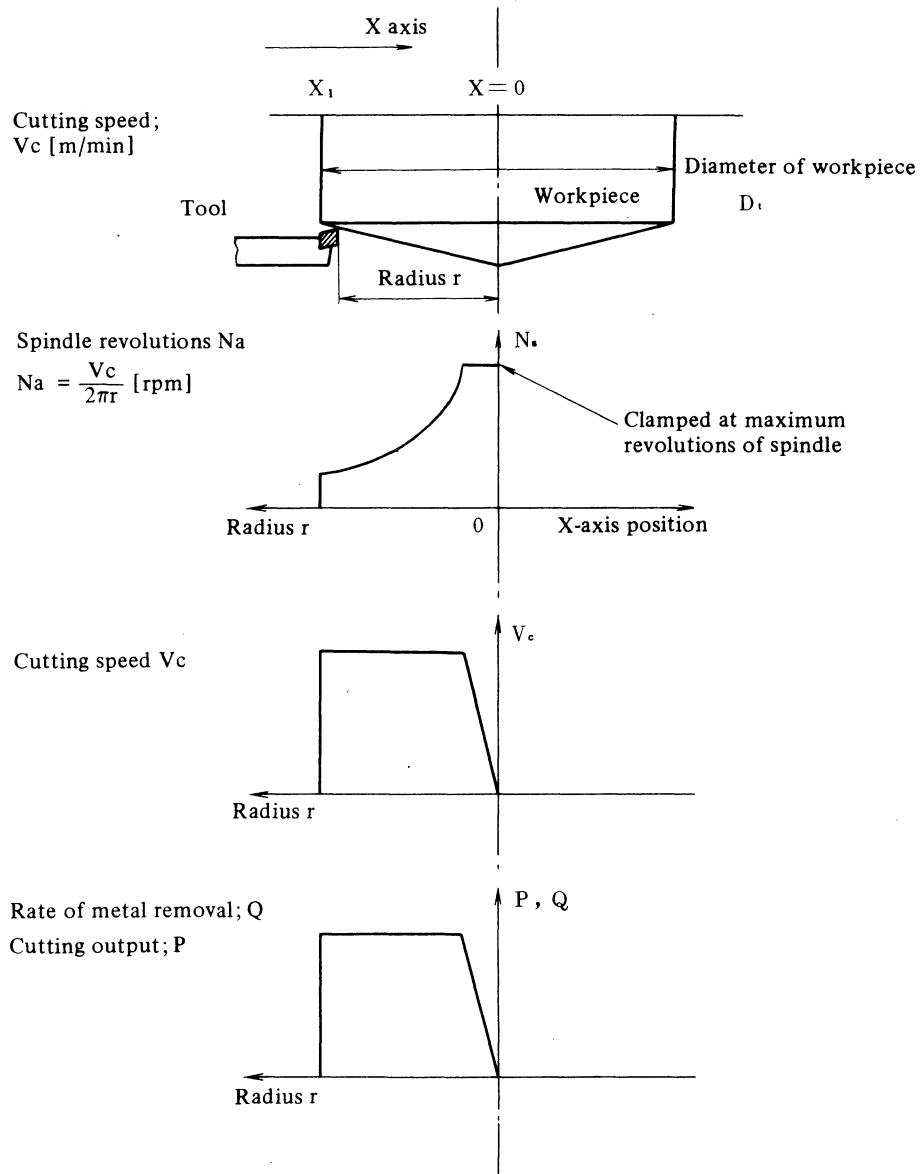

- The cutting output during constant surface speed control, or, the output required for cutting a metal during constant surface speed control under a certain condition is obtained by the following formula:

$$P_o = \frac{1}{MRT} \times d \times fr \times V_c \quad (\text{kW}) \quad \dots\dots\dots (6-1)$$

where, P_o : Cutting output (kW)
 MRT : Rate of metal removal per kW (20 usually) (cc/min/kW)
 d : Depth of cut (mm)
 fr : Feed rate (mm/rev)
 V_c : Cutting speed (m/min)

- Motor output required for constant surface speed control
 Both required cutting output and the output for acceleration (or deceleration) for increasing (or decreasing) the spindle revolutions are required, and the maximum output is required in the vicinity of the maximum revolutions of the motor.

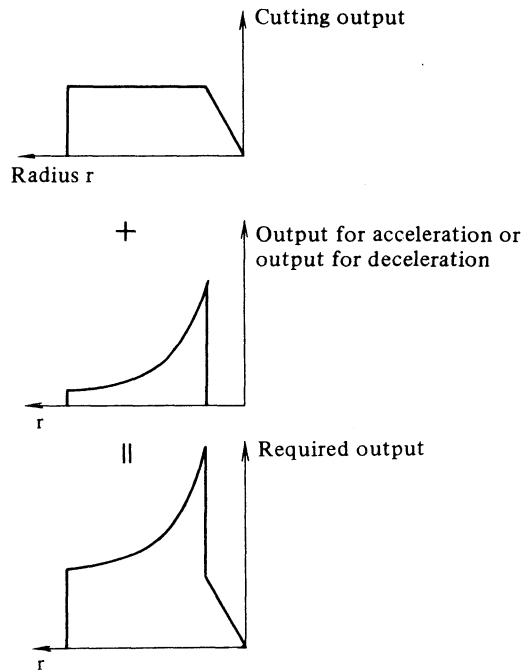

Since cutting speed V_c is kept constant under the constant surface speed control, the tool position (radius r) on a workpiece is inversely proportional to spindle revolutions N_s .

Thus, the feed rate per minute f_m (mm/min) becomes faster, as the tool advances toward the innermost of diameter.

Assume that the tool is displaced by $-\Delta X$ in the X-axis direction during Δt time, and a change rate

$-\frac{\Delta X}{\Delta t}$ represents the feed rate given by the following formula.

$$-\frac{dX}{dt} = f_m = \frac{fr \times V_c}{2\pi X} \quad \dots\dots\dots (6-2)$$

From the formula (6-2), the time required for the tool to be displaced from radius $X1 > r1$ to $X2 = r2$ is obtained by:

$$t_a = \frac{\pi}{f_r \times V_c} (r_1^2 - r_2^2) \text{ (sec)} \dots\dots\dots (6-3)$$

(where, $r_1 > r_2$)

This is the formula for obtaining the machining time under the constant surface speed control.

. Extension of constant surface speed control area (Patent pending)

The constant surface speed control area is extended over large diameter workpieces, and the feed rate is reduced by the reduction component of the motor output. In other words, when a large diameter workpiece is machined, the spindle revolutions are lowered, and the motor output is reduced by the reduction component of revolutions in the constant torque area. Accordingly, the feed rate is reduced, as the revolutions decrease, while keeping the circumferential speed constant in cutting machining.

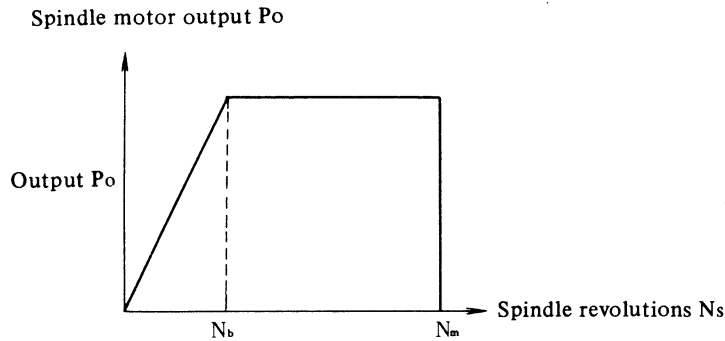

Feed f_r (mm/rev) is controlled as follows.

$$\left\{ \begin{array}{l} f_r' = f_r \times 1 \quad (N_s \geq N_b) \\ f_r' = f_r \times \frac{N_s}{N_b} \quad (N_s < N_b) \end{array} \right\} \dots\dots\dots (6-4)$$

Feedrate f_m (mm/min) is controlled as follows.

$$\left\{ \begin{array}{l} f_m' = f_r \times N_s \times 1 \quad (N_s \geq N_b) \\ f_m' = f_r \times N_s \times \frac{N_s}{N_b} \quad (N_s < N_b) \end{array} \right\} \dots\dots\dots (6-5)$$

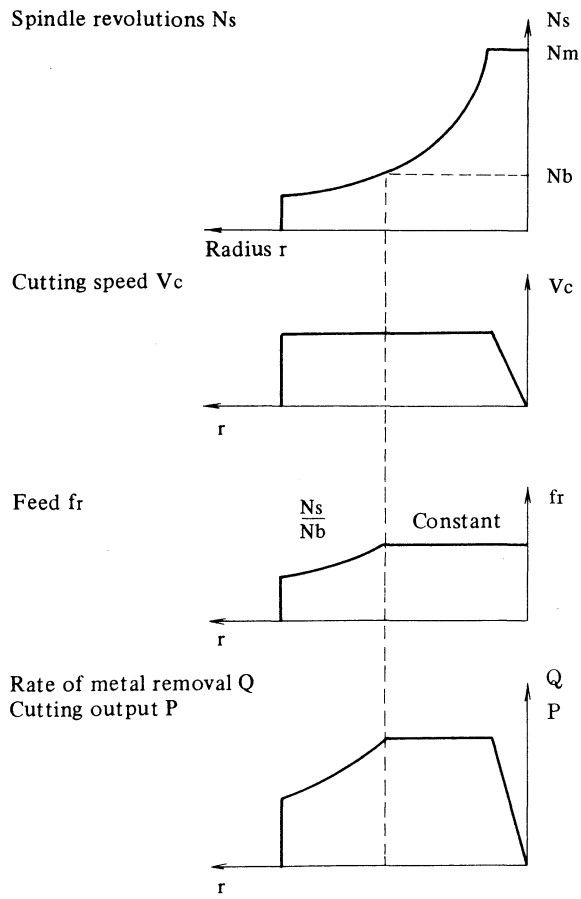
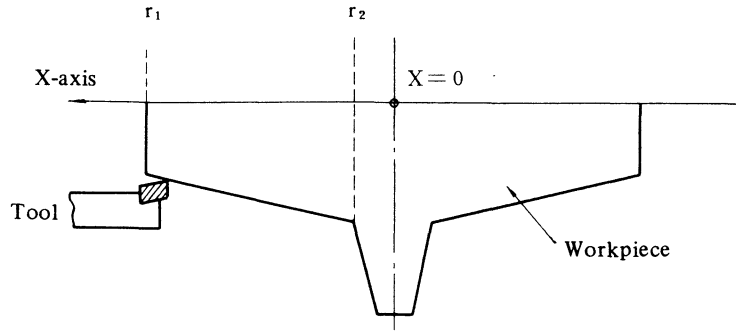

2.8 Tapping

1) Tapping operation

The tapping means a work of threading a female screw on a workpiece in machining center.

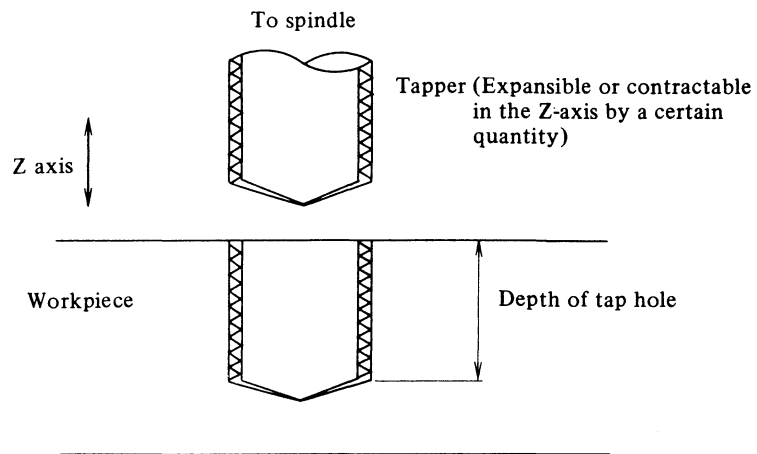

Tapping is made by controlling the spindle and Z-axis movement as follows.

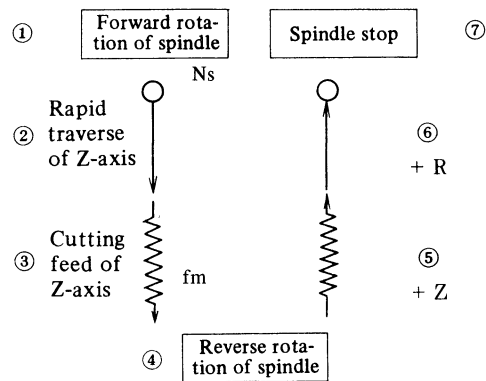

Spindle movement

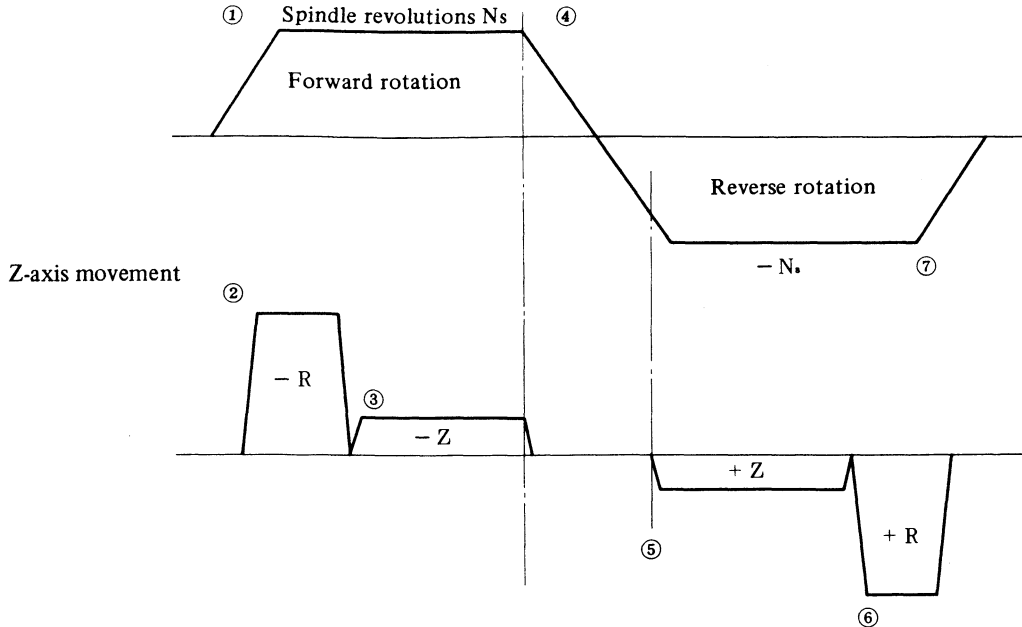

Examine the following items for tapping.

- a) Depth of tap hole Check if the depth is finished as specified.
- b) Expansion or contraction of taper This will affect the threading accuracy.

2) Tapping and cutting speed

In tapping work, the cutting speed is generally limited according to the kinds of workpieces and tools.

$$V_c = \pi \times d \times N_s / 1000 \quad (\text{m/min}) \quad \dots \dots \dots (7-1)$$

where, d : Tap diameter (mm)
 Ns: Spindle revolutions (rpm)

Example of tapping conditions

- . When a steel casting workpiece is tapped by an ordinary taper: Lower than 8 m/min
- . When a light alloy workpiece is tapped by an ordinary taper or when a cemented carbide taper is employed; Lower than 25 m/min

The relation between the tap diameter and spindle revolutions is as illustrated below.

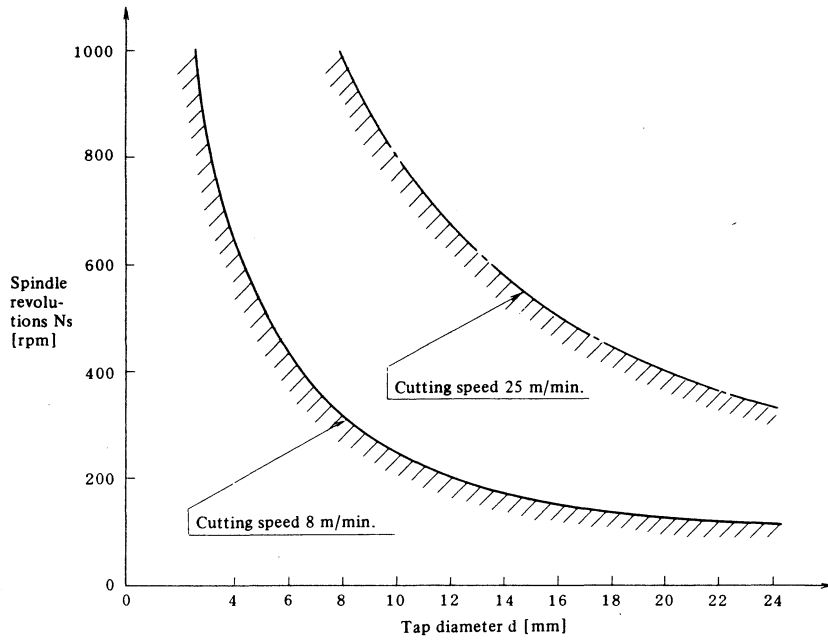

3) Feedrate during tapping work

Set the cutting feed rate f_m (mm/min) during tapping as follows.

$$f_m = N_s \times p \quad (\text{mm/min}) \quad \dots \dots \dots (7-2)$$

where, p : Pitch of screw

The relation between the tap diameter (nominal diameter of screw) and pitch is as shown below.

Nominal diameter of screw (d)	Pitch (p)	Height of engagement (H_1)
M 2	0.4 mm	0.217 mm
M 2.6	0.45	0.244
M 3	0.5	0.271
M 4	0.7	0.379
M 5	0.8	0.433
M 6	1.0	0.541
M 8	1.25	0.677
M10	1.5	0.812
M12	1.75	0.947
M16	2	1.083
M20	2.5	1.353
M24	3	1.624
M30	3.5	1.894
M36	4	2.165

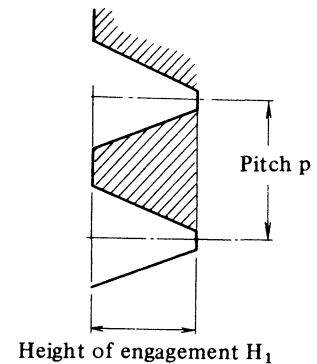

4) Tap hole depth control

The hole depth d_p (mm) is given by the following formula.

$$d_p = d_f + \lambda a \quad (\text{mm}) \quad \dots\dots\dots (7-3)$$

where, d_f : Moving distance commanded from a workpiece surface to Z-axis
 λa : Machining distance of taper by means of self-propulsion until the spindle is stopped after being decelerated (This is called flow quantity)

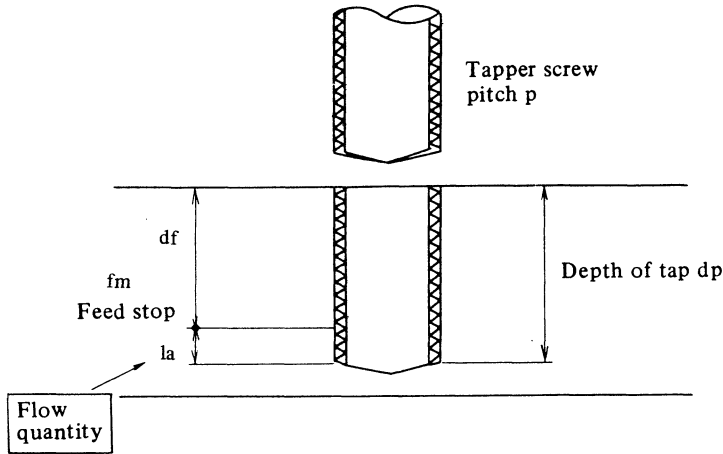

How to obtain flow quantity λa

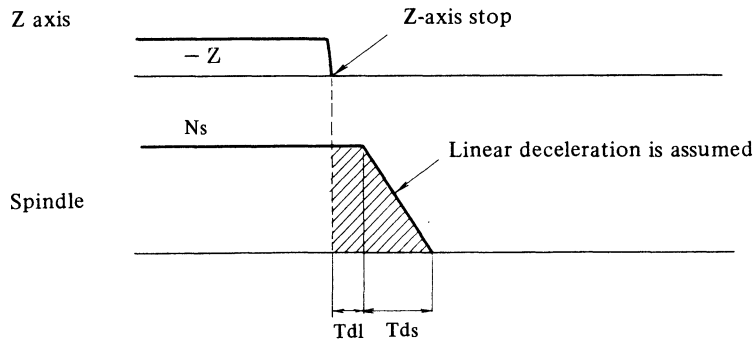

T_{d1} : Operation delay time by the time the spindle starts deceleration (sec)

T_{ds} : Deceleration time of spindle (sec)

$$\lambda a = (T_{d1} + \frac{1}{2} T_{ds}) \times \frac{N_s}{60} \times p \quad (\text{mm}) \quad \dots\dots\dots (7-4)$$

To decrease the flow quantity, the operation delay time and deceleration time must be reduced. This flow quantity corresponds to the expansion of the taper. It must be controlled to obtain the depth of holes accurately.

5) Expansion and contraction of taper

For the expansion and contraction of taper, refer to tools maker's catalogues. Contraction is generally less than expansion, and the spring pressure increases during contraction.

Accordingly, the finish accuracy of screws is said to be better when threading is made in the expansion direction of the taper rather than in the contraction direction.

The causes of expansion and contraction of the taper are as described below. Please examine the motor selection and power magnetic sequence design, so that tapping can be done with minimized expansion and contraction.

a) Expansion and contraction caused by the difference between the feed rate and actual spindle revolutions N_s

Expansion and contraction quantity ϵ_1 of taper caused by asynchronism between the feed rate and spindle revolutions

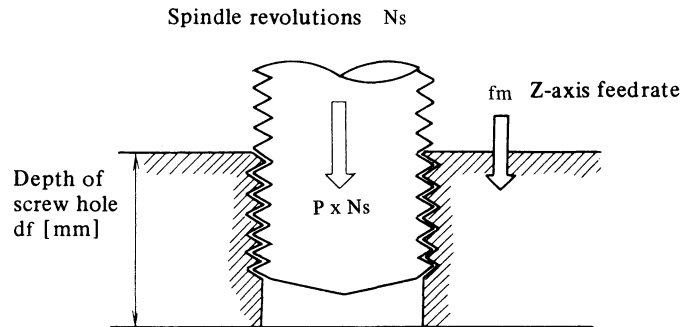

$pN_s - f_m = \text{positive}$ (expansion of taper)

$pN_s - f_m = \text{negative}$ (contraction of taper)

$$\epsilon_1 = \frac{pN_s - f_m}{f_m} \times df \quad (\text{mm}) \quad \dots \dots \dots (7-5)$$

The above relation is contrary when the taper is lifted. Particularly be careful with this relation when a hole is deep.

b) Expansion and contraction ϵ_2 caused by the forward/reverse rotation of spindle and Z-axis feed timing

① Pattern A

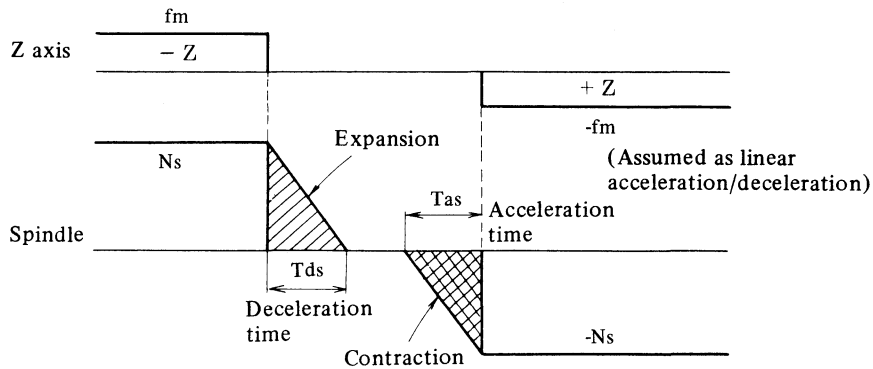

$$\epsilon_{2a} = \frac{1}{2} \times \frac{Ns}{60} \times p \times (Tds - Tas) \quad (\text{mm}) \quad \dots\dots\dots (7-6)$$

$Tds \leq Tas$ usually.

② Pattern B (Z-axis instantaneous reverse rotation)

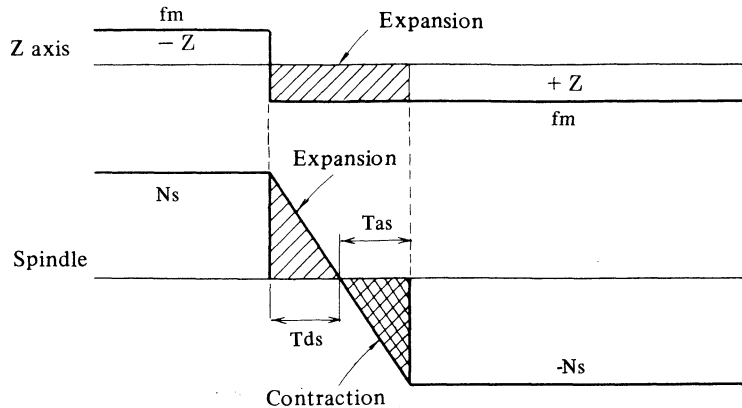

$$\epsilon_{2b} = \frac{1}{2} \times \frac{Ns}{60} \times p \times (Tds - Tas) + \frac{f_m}{60} \times (Tds + Tas) \quad (\text{mm}) \quad \dots\dots (7-7)$$

③ Pattern C

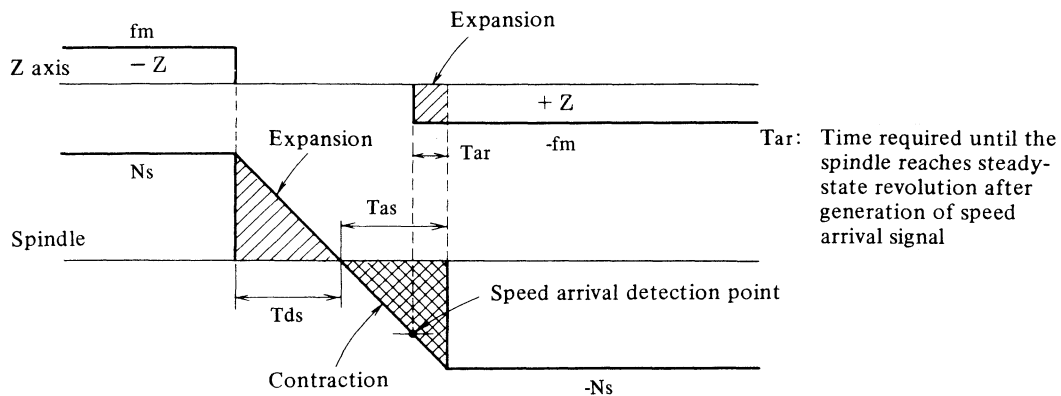

$$\epsilon_{2c} = \frac{1}{2} \times \frac{Ns}{60} \times p \times (Tds - Tas) + \frac{f_m}{60} \times Tar \quad \dots\dots\dots (7-8)$$

6) Examination to minimize the expansion and contraction of taper

- ① Synchronize the commanded spindle speed with actual spindle speed.
- ② Control the reverse rotation start time of the Z-axis feed motor as shown in pattern C until expansion/contraction $\epsilon_{2c} \approx 0$.
Adjust the detection level of the speed arrival signal from the spindle servo unit as a method.

- ③ Shorten the acceleration and deceleration time of spindle.
Switch gears from low gear to high gear at revolutions lower than normal gear switching point for the purpose of shortening the acceleration and deceleration time of the spindle during tapping work only.

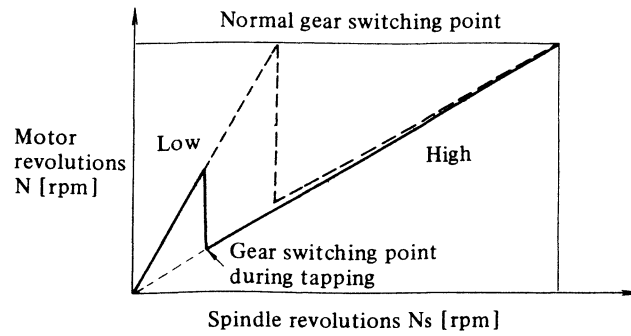

2.9 How to Find Allowable Duty Cycle

When the spindle accelerates and decelerates frequently for machining, the motor should be used so that the average output value of one cycle of operation does not exceed the continuous rated output.

Following is the description of the method of calculating its allowable duty cycle for a typical AC spindle motor.

1) Duty cycle and average output

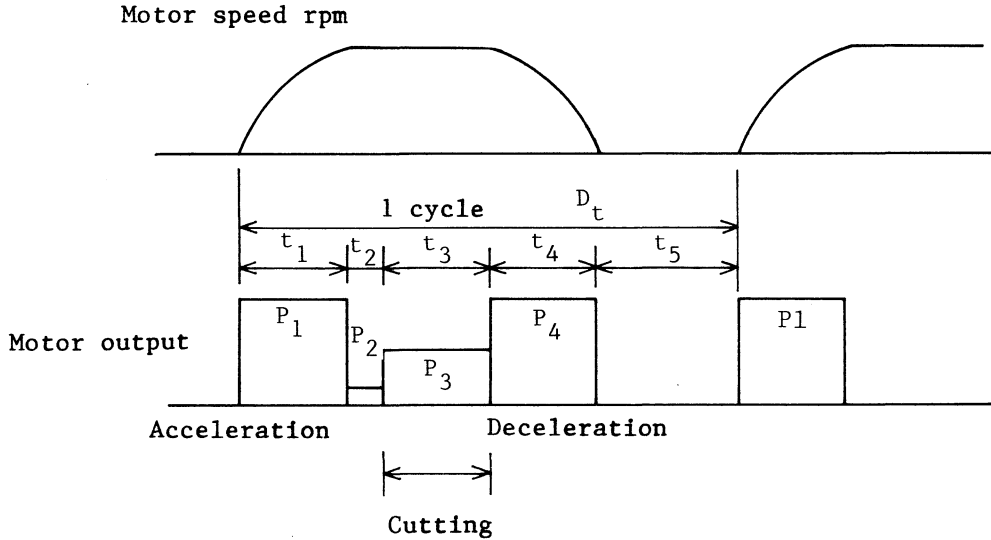

- P_1, P_4 : Output at acceleration and deceleration (kW) = 30-minute rated output x 1.2
- P_2 : Output at no-load rotation ($P = 0$)
- P_3 : Output during cutting (kW)

$$\text{Average output } P_{av} = \sqrt{\frac{P_1^2 t_1 + P_2^2 t_2 + P_3^2 t_3 + P_4^2 t_4}{D_t}} \dots\dots\dots (8-1)$$

Note) As to output P_3 during cutting at motor speed N which is less than base speed N_b , assuming actual cutting output to be P_c (kW), the value is obtained by the following equation.

$$P_3 \cong \frac{N_b}{N} \times P_c \text{ (kW)} \dots\dots\dots (8-2)$$

2) How to find allowable duty cycle time D_t :
From eq. (8-1) above, D_t is determined by:

$$D_t = \frac{1}{P_{av}^2} \times (P_1^2 t_1 + P_2^2 t_2 + P_3^2 t_3 + P_4^2 t_4) \dots\dots\dots (8-3)$$

Substitute the continuous rated output value of AC spindle motor used for P_{av} (kW).

Ex: Find the allowable duty cycle time when acceleration and deceleration are repeated at no load ($P_2 = P_3 = 0$) for model 3.

o Continuous rated output: $P_{av} = P_{cont} = 3.7 \text{ kW}$

o Output at acceleration/deceleration: $P_1 = P_4 = 5.5 \text{ kW} \times 1.2 = 6.6 \text{ kW}$

o Acceleration time $t_1 = 3 \text{ sec}$

Deceleration time $t_4 = 3 \text{ sec}$

Under the aforementioned conditions, D_t is found as follows.

$$D_t = \frac{1}{3.7^2} \times (6.6^2 \times 3 + 6.6^2 \times 3)$$

$$= \frac{6.6^2}{3.7^2} \times (2 \times 3) = 19.08 \text{ seconds}$$

In other words, the allowable duty time when acceleration and deceleration are repeated at no load for model 3 corresponds to 3.18 times the summation of the acceleration and deceleration times.

3) Allowable duty cycle time D_t for repeated acceleration and deceleration

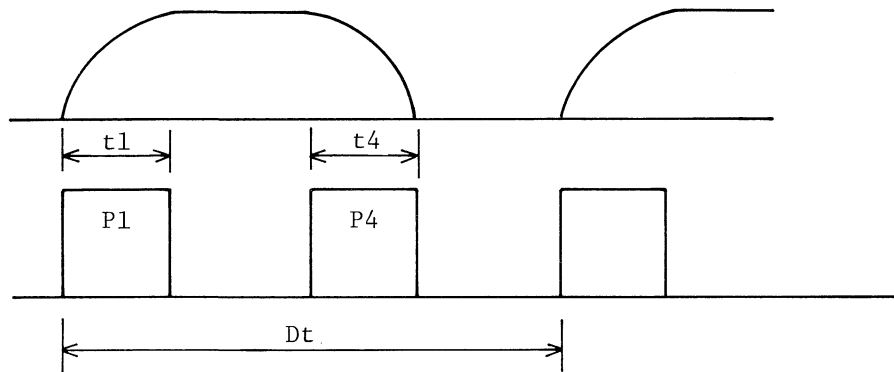

$$D_t = \frac{1}{P_{cont}^2} \left\{ P_{230 \text{ min}} \times 1.2^2 \times (t_1 + t_4) \right\} \dots \dots \dots (8-3)$$

where, P_{cont} : Continuous rated output
 $P_{230 \text{ min}}$: 30-minute rated output
 $t_1 + t_4$: Summation of acceleration time and deceleration time

$$D_t = \left(\frac{P_{230 \text{ min}} \times 1.2}{P_{cont}} \right)^2 \times (t_1 + t_4) = K_m \times (t_1 + t_4) \text{ (seconds)} \dots \dots \dots (8-4)$$

The K_m value of each motor model is shown in the table below.

Model	Value of K_m
1S	3.10
1.5S	16.29
2S	4.07
3S	3.18
6S	2.68
8S	3.10
12S	2.68
15S	2.19
18S	2.04
22S	2.01

2.10 How to Find the Orientation Time

The spindle orientation operation has two systems: the magnetic sensor system and position coder system. Find the orientation time from a stop for each system.

1) Magnetic sensor system

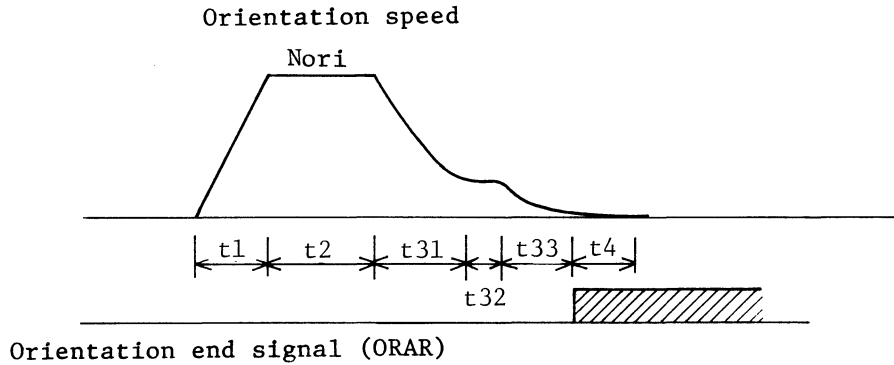

a) $t_1 = \frac{J_L + J_m}{T_m} \times \frac{2\pi}{60} \text{ Nori (sec)} \dots\dots\dots (10-1)$

where, $\text{Nori} \leq \text{Nb} (=1500 \text{ rpm})$

b) $t_{2\text{max}} = \frac{1}{\frac{\text{Nori}}{60}} \text{ (sec)} \dots\dots\dots (10-2)$

In this period, the spindle rotates a maximum of one revolution.

$\text{Nori} = 55 \times K_p \text{ (rpm)} \dots\dots\dots (10-3)$

Where, position gain K_p is nearly 5 to 30 for the spindle. For a machine with compact models 1, 2, approx. 30 may be available for K_p ; however, K_p is normally 5 to 15.

c) $t_{31} + t_{33} \approx \frac{3}{K_p} \text{ (sec)} \dots\dots\dots (10-4)$

d) t_{32}
For stable control, set this time as follows.

$t_{32\text{max}} = 0.2 \text{ (sec)} \dots\dots\dots (10-5)$

e) t_4
The motor operates for nearly the following time before it nearly stops after the orientation end signal is given.

$t_4 = \frac{2}{K_p} \text{ (sec)} \dots\dots\dots (10-6)$

Ex: When position gain $K_p = 5$, the orientation time t_{ori} is as follows at load inertia $J_L = 0.0022 \text{ kg.m.s}^2$ for model 3.

$$1) t_1 = \frac{J_L + J_m}{T_m} = \frac{0.0022 + 0.0022}{0.71} \times \frac{2\pi}{60} \times 55 \times 5 = 0.18 \text{ sec}$$

$$2) t_2^{\max} = \frac{1}{\frac{Nori}{60}} = \frac{60}{55 \times 5} = 0.22 \text{ sec}$$

$$3) t_{31} + t_{33} = 0.6 \text{ sec}$$

$$4) t_{32} = 0.2 \text{ sec}$$

$$5) t_4 = 0.4 \text{ sec}$$

$$t_{ori} = t_1 + t_2^{\max} + t_{31} + t_{33} + t_{32} + t_4 = 1.6 \text{ sec}$$

The time when the orientation end signal is issued is $t_{ori} = 1.2 \text{ sec}$.

Also, the orientation time during rotation is the deceleration time plus $(t_2^{\max} + t_{31} + t_{33} + t_{32} + t_4)$.

2) Position coder system

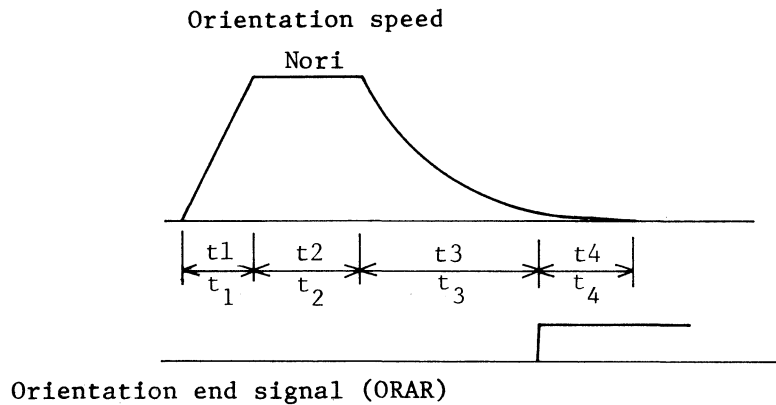

a) $t_1 = \frac{J_L + J_m}{T_m} \times \frac{2\pi}{60} \times Nori \text{ (sec)} \dots\dots\dots (10-7)$

b) $t_2^{\max} = \frac{2}{\frac{Nori}{60}}$ Note) The motor gives 2 turns maximum.

$Nori = 30 \times K_p$
Position gain K_p is 5 to 30, and normally 5 to 15.

c) $t_3 = \frac{3}{K_p} \text{ (sec)}$

d) $t_4 = \frac{2}{K_p} \text{ (sec)}$

$$t_{ori} = t_1 + t_2^{\max} + t_3 + t_4$$

APPENDIX 3 EXAMPLE OF COOLING FAN MOTOR OF UNIT
(Used in July, 1990 or earlier)

As an example of a fan motor for cooling, the model #5915PC made by N.M.B. is shown below. For three-phase fan motors, refer to Chapter 7 "Cooling."

[Specifications]

Model	Voltage V	Fre- quency Hz	Max. air flow m ³ / min	Max. static pres- sure mmAq	Speed rpm	Cur- rent A	Input power W	Noise dB	Weight kg
5915PC-20W-B20-04	200 ^{+10%} -15%, 1φ	50	5.5	13	2550	0.14	26	53	0.8
	200 ^{+10%} -15%, 1φ	60	6.0	16	2600	0.17	31	55	
	220 ^{+10%} -15%, 1φ								

[External dimensions]

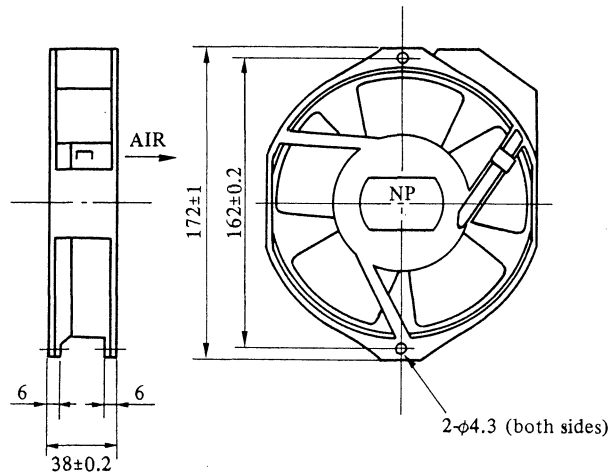

APPENDIX 4 GROUNDING

The S series servo unit employs the plastic body, therefore ground the unit according to the following descriptions. When grounding the unit improperly the motor may fluctuate, noise or the spindle gear may noise due to a noise of the speed command voltage.

- 1) Shielded ground line
 - a) Corrective ground

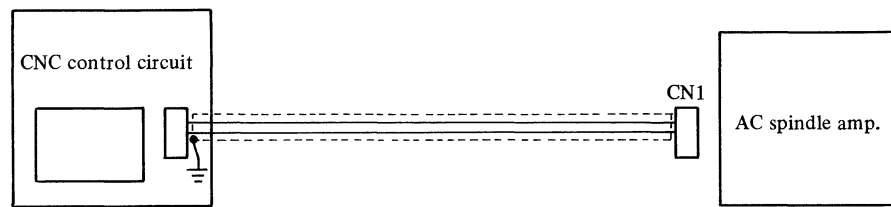
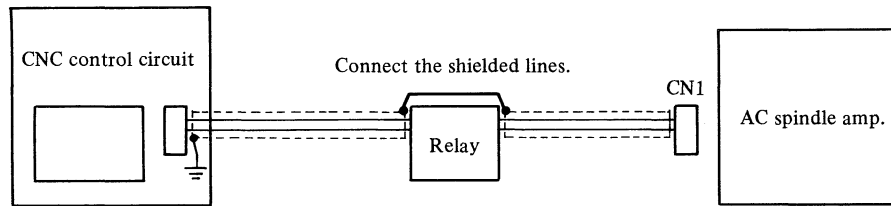

Extent the shielded line close to the pin of connector CN1

Note) Use the 2-core shielded line.

- b) Example of improper ground

Ex 1) The shielded line for the speed command voltage is terminated.

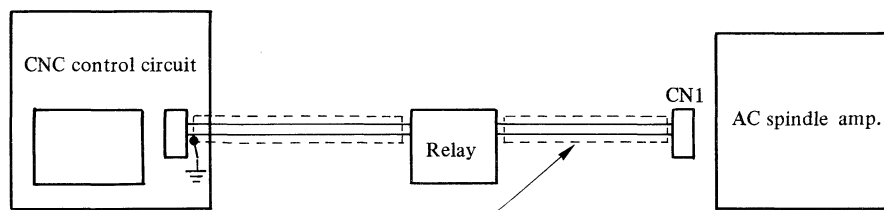

The electric potential of this shielded line is indefinite and the shielded effective is not made.

Ex 2) The shielded lines are grounded respectively

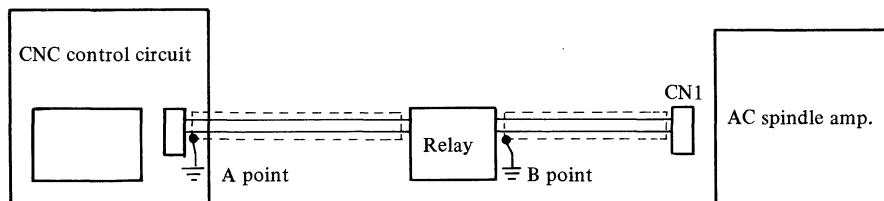

The electric potential difference between points A and B temporarily generates and the potential of shielded lines may differ.

Ex 3) The shielded line is terminated

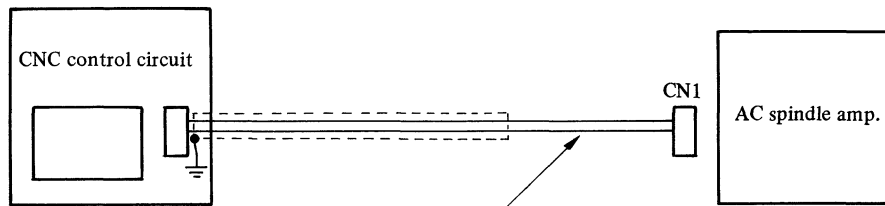

The shielded line is terminated and is bundled together with the power line.

2) Grounding

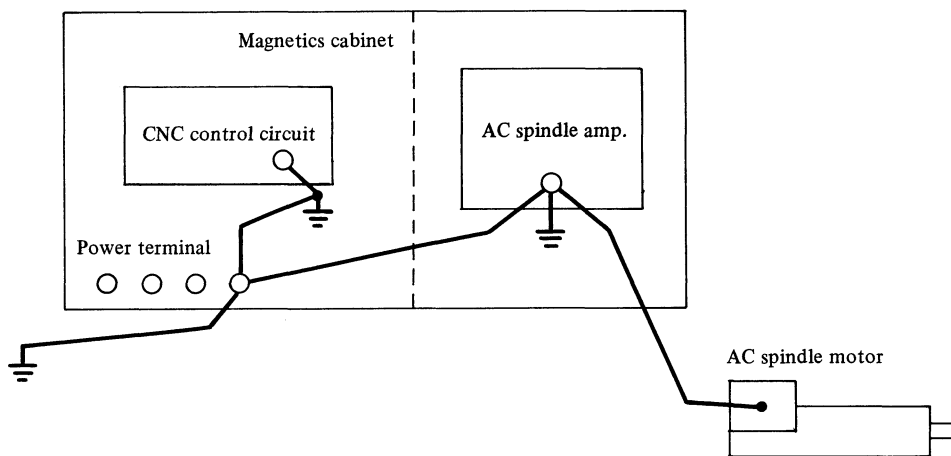

- ① Connect the G terminal of the AC spindle amp. to the G terminal of the power terminal.
- ② Connect the G terminal of the AC spindle motor to the G terminal of the AC spindle amp.
- ③ Connect the G terminal of the AC spindle amp. close to the position of the magnetics cabinet. Place the G terminal close to the cabinet as much as possible to get more effective grounding.

Note 1) Connect the G terminal of the magnetics cabinet to the ground terminal according to the technical standard authorized.

Note 2) For connecting the G terminal of the CNC to the ground terminal, the ground terminal to the ground plate and the ground terminal to the G terminal of the power terminal of the magnetics cabinet, use the thick cable and connect it close to each other.

Revision Record

AC SPINDLE MOTOR series (S series/P series/VH series) DESCRIPTIONS (B-65012E)

03	'91.3	<ol style="list-style-type: none"> 1. The explanation for AC spindle motor S series (high-speed model) has been added. 2. The explanation for AC spindle servo unit S series (high-speed model) has been added. 3. The explanation for AC spindle motor VH series has been added. 4. The explanation for built-in sensor signal conversion circuit has been modified. 5. The explanation for spindle switching control circuit has been added. 					
02	'89, 1	Total revision					
01	'87, 11	_____					
Edition	Date	Contents	Edition	Date	Contents	Edition	Contents

- *No part of this manual may be reproduced in any form.*
- *All specifications and designs are subject to change without notice.*